

COPYRIGHT © Hangzhou EZVIZ Software Co., Ltd. ALL RIGHTS RESERVED.

Any and all information, including, among others, wordings, pictures, graphs are the properties of Hangzhou EZVIZ Software Co., Ltd. (hereinafter referred to as “EZVIZ”). This user manual (hereinafter referred to as “the Manual”) cannot be reproduced, changed, translated, or distributed, partially or wholly, by any means, without the prior written permission of EZVIZ. Unless otherwise stipulated, EZVIZ does not make any warranties, guarantees or representations, express or implied, regarding to the Manual.

About this Manual

The Manual includes instructions for using and managing the product. Pictures, charts, images and all other information hereinafter are for description and explanation only. The information contained in the Manual is subject to change, without notice, due to firmware updates or other reasons. Please find the latest version in the EZVIZ™ website (<http://www.ezviz.com>).

Revision Record

New release – January, 2023

Trademarks Acknowledgement

EZVIZ™, ™, and other EZVIZ's trademarks and logos are the properties of EZVIZ in various jurisdictions. Other trademarks and logos mentioned below are the properties of their respective owners.

Legal Disclaimer

TO THE MAXIMUM EXTENT PERMITTED BY APPLICABLE LAW, THE PRODUCT DESCRIBED, WITH ITS HARDWARE, SOFTWARE AND FIRMWARE, IS PROVIDED “AS IS”, WITH ALL FAULTS AND ERRORS, AND EZVIZ MAKES NO WARRANTIES, EXPRESS OR IMPLIED, INCLUDING WITHOUT LIMITATION, MERCHANTABILITY, SATISFACTORY QUALITY, FITNESS FOR A PARTICULAR PURPOSE, AND NON-INFRINGEMENT OF THIRD PARTY. IN NO EVENT WILL EZVIZ, ITS DIRECTORS, OFFICERS, EMPLOYEES, OR AGENTS BE LIABLE TO YOU FOR ANY SPECIAL, CONSEQUENTIAL, INCIDENTAL, OR INDIRECT DAMAGES, INCLUDING, AMONG OTHERS, DAMAGES FOR LOSS OF BUSINESS PROFITS, BUSINESS INTERRUPTION, OR LOSS OF DATA OR DOCUMENTATION, IN CONNECTION WITH THE USE OF THIS PRODUCT, EVEN IF EZVIZ HAS BEEN ADVISED OF THE POSSIBILITY OF SUCH DAMAGES.

TO THE MAXIMUM EXTENT PERMITTED BY APPLICABLE LAW, IN NO EVENT SHALL EZVIZ'S TOTAL LIABILITY FOR ALL DAMAGES EXCEED THE ORIGINAL PURCHASE PRICE OF THE PRODUCT.

EZVIZ DOES NOT UNDERTAKE ANY LIABILITY FOR PERSONAL INJURY OR PROPERTY DAMAGE AS THE RESULT OF PRODUCT INTERRUPTION OR SERVICE TERMINATION CAUSED BY: A) IMPROPER INSTALLATION OR USAGE OTHER THAN AS REQUESTED; B) THE PROTECTION OF NATIONAL OR PUBLIC INTERESTS; C) FORCE MAJEURE; D) YOURSELF OR THE THIRD PARTY, INCLUDING WITHOUT LIMITATION, USING ANY THIRD PARTY'S PRODUCTS, SOFTWARE, APPLICATIONS, AND AMONG OTHERS.

REGARDING TO THE PRODUCT WITH INTERNET ACCESS, THE USE OF PRODUCT SHALL BE WHOLLY AT YOUR OWN RISKS. EZVIZ SHALL NOT TAKE ANY RESPONSIBILITIES FOR ABNORMAL OPERATION, PRIVACY LEAKAGE OR OTHER DAMAGES RESULTING FROM CYBER ATTACK, HACKER ATTACK, VIRUS INSPECTION, OR OTHER INTERNET SECURITY RISKS; HOWEVER, EZVIZ WILL PROVIDE TIMELY TECHNICAL SUPPORT IF REQUIRED. SURVEILLANCE LAWS AND DATA PROTECTION LAWS VARY BY JURISDICTION. PLEASE CHECK ALL RELEVANT LAWS IN YOUR JURISDICTION BEFORE USING THIS PRODUCT IN ORDER TO ENSURE THAT YOUR USE CONFORMS TO THE APPLICABLE LAW. EZVIZ SHALL NOT BE LIABLE IN THE EVENT THAT THIS PRODUCT IS USED WITH ILLEGITIMATE PURPOSES.

IN THE EVENT OF ANY CONFLICTS BETWEEN THE ABOVE AND THE APPLICABLE LAW, THE LATTER PREVAILS.

Table of Contents

IMPORTANT SAFETY INSTRUCTIONS	1
Overview	2
1. Package Contents	2
2. General.....	3
3. Basics	3
About the Name Card	4
Setup	5
1. Get the EZVIZ App	5
2. Wiring	5
3. Install the Intercom Panel.....	8
4. Install the Monitor	10
5. Install the Keypad.....	11
6. Install Micro SD Card (Optional)	12
7. Connect Your EZVIZ Video Doorphone To Your Smartphone.....	13
8. Configure the RFID Badge	13
9. Bind the Keypad	14
10. Multiple Unlocking Methods.....	14
Maintenance	15
1. Disassemble the Keypad	15
2. Change the Batteries (Optional).....	15
View Your Device on the EZVIZ App	16
1. Live View.....	16
2. Settings	17
EZVIZ Connect	18
1. Use Amazon Alexa.....	18
2. Use Google Assistant	19
SAFETY PRECAUTIONS	20
Initiatives on the Use of Video Products	21

IMPORTANT SAFETY INSTRUCTIONS



Important!

1. Please read the user manual carefully before installing or using this product.
2. If you are installing this product for a third party, please remember to leave the manual or a copy of it with the end user.

Safety measures:

1. To operate this system in complete safety, it is essential that the installers, users, and technicians follow all of the safety procedures described in this manual.
2. Specific warnings and warning symbols are given for items if necessary.
3. The product must be set up according to the applicable standards in the country where it is installed.

Overview

1. Package Contents



Monitor (x1)
7" touch screen

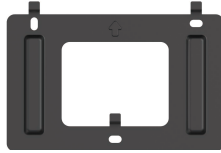

Wall Bracket for Monitor (x1)

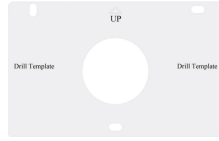

Drill Template for Monitor (x1)



Pin (x1)



Intercom Panel (Doorbell)
with a Weather-proof Shield (x1)



Drill Template for Intercom
Panel (x1)



Transformer (x1)



Ferrite Core (x1)



Keypad (x1)



Wall Bracket for Keypad (x1)



Drill Template for Keypad (x1)



AA-sized Battery (x2)



Screwdriver (x1)



Badges (x5)



DC 24V Power Supply Jack
Connector Cable (x1)



Screw Kit (x3)



Name card (x2)



Wire Connectors (x3)



Regulatory Information (x2)



Quick Start Guide (x1)

2. General

This video doorphone consists of an indoor answering unit with a touch screen, an outdoor keypad, and outdoor panel with an intercom allowing you to see and communicate with the visitor who has pressed the doorbell button. It is easy to install as six wires are needed for all functions: the doorbell, the video feed, the intercom, and the opening controls (strike plate and automated gate opening).

The system can operate up to two monitors and two Intercom Panels.

To get the most out of your intercom, please read this instruction manual carefully.

3. Basics

Monitor

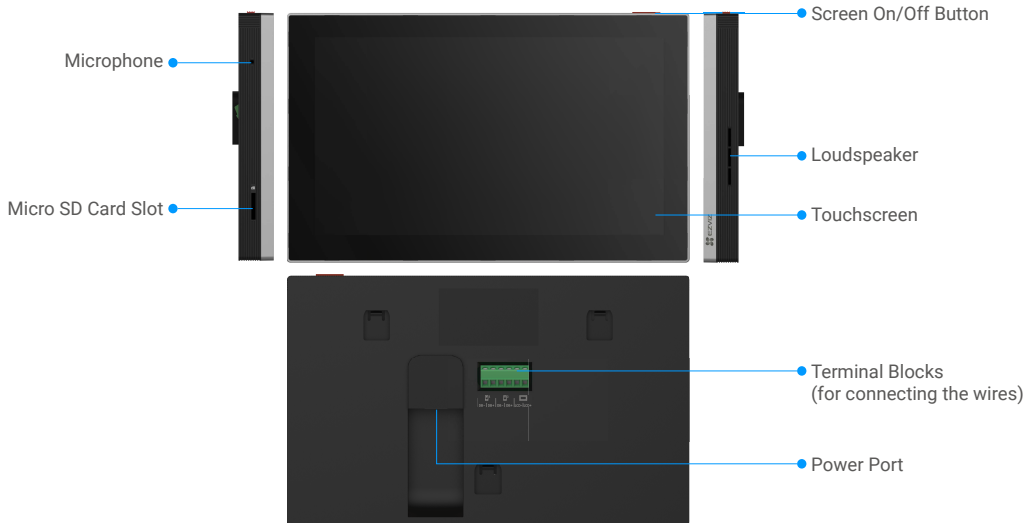

Name	Description
Power Port	For powering up the monitor.
Screen On/Off Button	<ul style="list-style-type: none">• Press to turn on/off the screen.• Press and hold for 8s to restart the monitor.
Micro SD Card (sold Separately)	Initialize the card in the EZVIZ app before using it. Recommended compatibility: Class 10, maximum space 512GB.



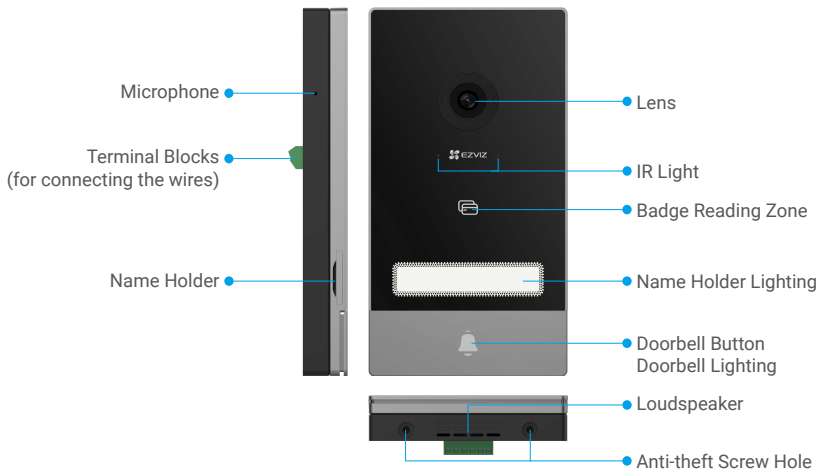

Intercom Panel (Doorbell)

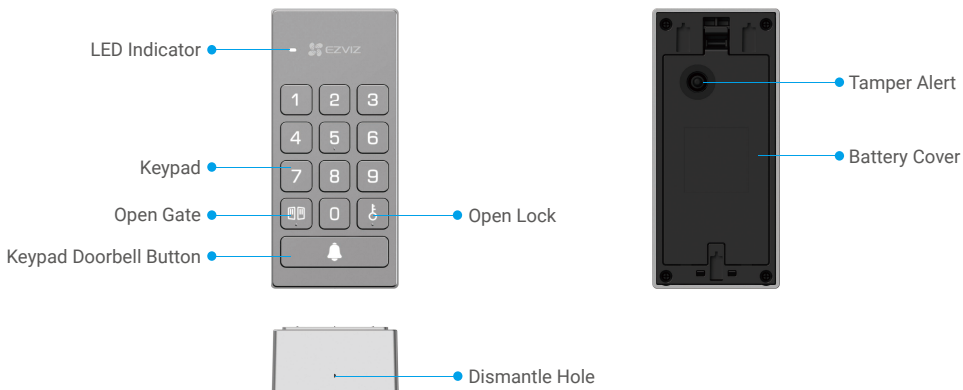

- When someone presses the doorbell button, the inside monitor rings and the video is displayed.
- To change the label in the name holder, pull the name holder tray from the left side of the device.

Keypad



Name	Description
LED Indicator	 Solid Red: Powered on, unpairing.
	 Flashing Red: Pairing failed/device exception.
	 Solid White: Pairing successfully
	 Slow-flashing White: Pairing mode.
	 Flashing White Twice: The keypad doorbell button has been pressed.

About the Name Card

- A name card has been pasted into the intercom panel included in the package, and you can write the name directly on it.
- There are 2 additional name cards included in the package, please keep them for further use.
- The name card can be torned off, and a new name card can be pasted over it.
- If you don't want to stick a name card, you can also use a marker to write the name directly on the name holder.
- The area of the name holder can be lit up, which can be managed through the EZVIZ App.
- We recommend you draw out the name holder and write the name, before installing the intercom panel on the weather-proof shield.

Setup

Follow the steps to set your system:

1. Get the EZVIZ app, and log in to your EZVIZ app account.
2. Wiring your system.
3. Install the intercom panel, monitor, and the Keypad.
4. Add the monitor to your EZVIZ account.
5. Bind the Keypad to the intercom panel.

1. Get the EZVIZ App

1. Connect your mobile phone to Wi-Fi (suggested).
2. Download and install the EZVIZ app by searching "EZVIZ" in the App Store or Google Play™.
3. Launch the app and register an EZVIZ user account.

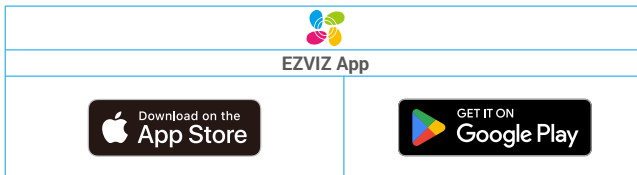

- i** If you have already used the app, please make sure that it is the latest version. To find out if an update is available, go to the app store and search for EZVIZ.

2. Wiring

2.1. Shut off the Electricity at the Breaker

- ⚠ Warning:** Since you'll be working with high-voltage electricity, first shut off the main power switch on your fusebox or consumer unit.

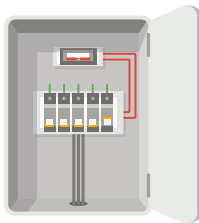

- i** In order for EZVIZ monitor to function properly, 24V DC power is a must. Please check if your existing transformer meets this requirement. If not, please replace yours with the one in the package.

2.2 Wire your Transformer

1. Connect these 2 wires to your transformer, making sure not to swap the mains and secondary wires.
2. Insert the wire ends into each clamp-down terminal, and tighten each connection with a screwdriver.
3. Make sure that each wire is securely clamped for a solid connection.

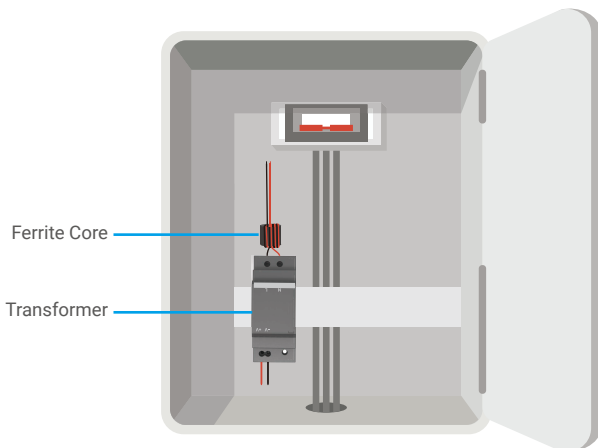

i In order to avoid the risks of EMC interference to other devices, the power wires from the fusebox needs to be threaded through the ferrite core and wrapped around the it four times before being connected to the AC input of the transformer.

In order to avoid the risks of interference and malfunction, do not pass the wires for your video doorphone through the same sheath as the electrical wires.

Warning: Do not double up the wires to increase the cross-section under any circumstances.

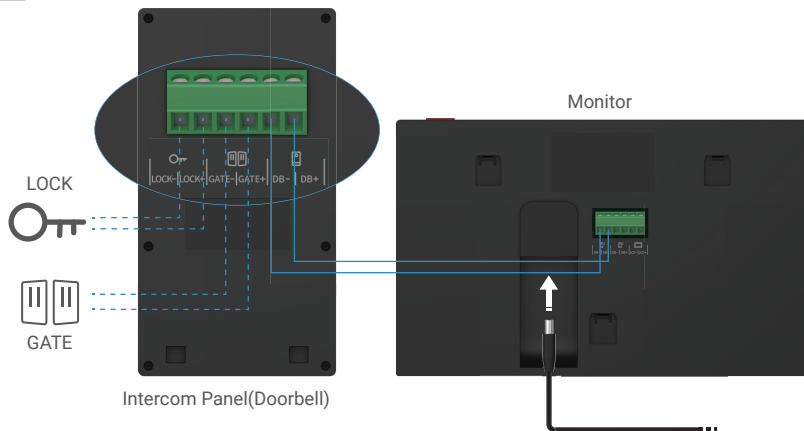

Warning: Please make sure that all the wires are well connected restore power at the breaker.

If you have reserved a DC 24V power supply hole on the wall, you can install the monitor above the hole and connect the monitor to the power supply (24V DC) by using the DC 24V power supply Jack connector cable, so that no exposed cables will be left on the wall.



DC 24V Power Supply Jack Connector Cable

Please follow the instructions below to connect the wires, if not, it may cause serious damage to the device.

1. Connect the **Red (+24V DC)** wire from the DC 24V power supply Jack connector cable to the **+24V DC** wire from your wall.
2. Connect the **Black (Ground)** wire from the DC 24V power supply Jack connector cable to the **Ground** wire from your wall.

DC 24V Power Supply Jack Connector Cable
Red (+24V DC)
Black (Ground)

Connect to

Power supply on your wall
+24V DC wire
Ground

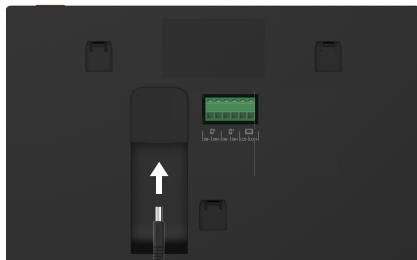

Recommended Installation Location

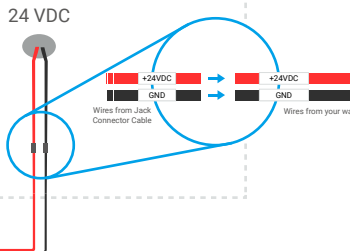

Warning: Please make sure that all the wires are well connected before you connect the another end of the DC 24V power supply Jack connector cable into the monitor's power port.

1-1 wiring diagram

	Ø 2 x 0.75mm ²	Ø 2 x 1.5mm ²	Twisted Pair(TP)
	0-50m	0-100m	up to 120m
	1-10m	1-10m	1-10m

i The remaining 4 terminal blocks (DB-/, LCD-/) on the monitor can be left unwired, it will be used for extended in the future

2.1. Connect the Video Doorphone (Monitor, Intercom Panel)

Properly connect the wires according to the wiring diagram (1-1). Terminals DB- and DB+ of the monitor to intercom panel DB- and DB+ terminals.

2.2. Connect an Electric Strike Plate or Lock

Connect it directly to terminals LOCK- and LOCK+ on the back of the intercom panel.

For wiring, refer to the label on the back of the intercom panel.

i Note that this function is only valid if the screen is displaying the exterior video feed. An indicator will appear to confirm.

Warning: To ensure that the electric strike plate or lock can be unlocked by the video doorphone, you should meet the following two conditions:

1. The electric strike plate or lock that you order must have a mechanical memory.
 2. The power supply to the electric strike plate or lock must not exceed 12V/1.1A
- If the power supply to the electric strike plate or lock exceeds 12V/1.1A, do as follows.

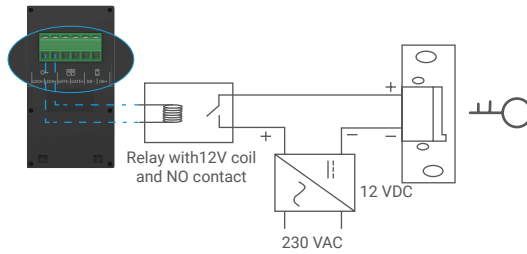

2.3. Connect a Gate Motor

Directly connect the gate motor wires to terminals GATE- and GATE+ on the back of the intercom panel. The intercom panel provides a 'dry'-contact connection, without an electric current, to connect to the button for your automated gate.

i Note that this function is only valid if the screen is displaying the exterior video feed. An indicator will appear to confirm.

! **Important:** The gate control: Breaking Capacity: 12V/2A.

For better electromagnetic radiation resistance, please use twisted pair cable to connect the monitor and the the Intercom Panel.

3. Install the Intercom Panel

! Advice and important instructions:

- If you test your product before installing it, ensure that you do not test it with the Intercom Panel and the monitor in the same room to avoid the video doorphone emitting a shrill noise.
 - Do not expose the intercom panel lens to direct sunlight or a reflective surface.
- Tip: we recommend that you use a protective sheath when doing the cabling in order to protect the cables against breakage and bad weather.**
- For the EZVIZ model, so as to get the most out of monitor's Wi-Fi function, we recommend that you check that your Wi-Fi network is accessible in your planned installation location

- 1 Remove the screws under the intercom panel, and tilt the intercom panel forwards.

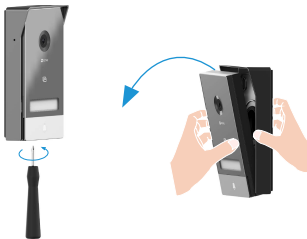

- 2 Draw out the name holder and write the name on the name card, take back the name holder.

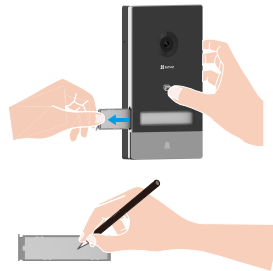

- 3 The lens of the panel must be placed at a height around 1.60m.

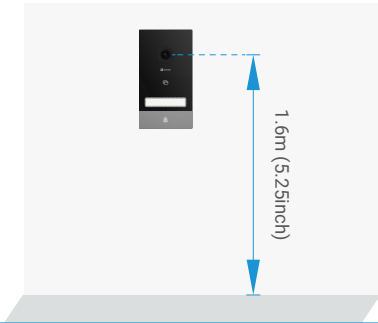

- 4 Place the drill template, take the wires through the holes of the drill template and the weather-proof shield, then firmly attach the weather-proof shield with anchors and screws to the wall.

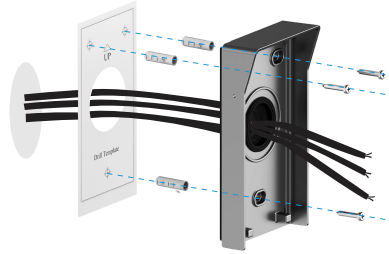

- 5 Connect the wires to the terminal blocks of the intercom panel according to the wiring diagram 1-1. (Use the screwdriver included).

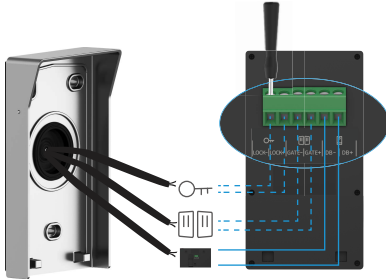

- 6 Fit the intercom panel onto its weather-proof shield.



- 7 Re-Install the attachment screws with the screwdriver (included).

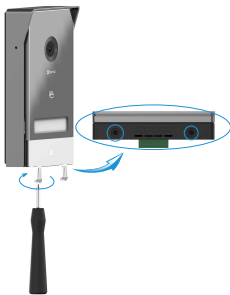

! Important: For a better image quality, please remove the protective film from the intercom panel before using it.



Tip: It is recommended that the wires be passed through a sheath to protect them from impacts and weather.

4. Install the Monitor

- 1 Place the drill template for monitor so that the monitor screen is at a height of around 1.60 m above the ground.

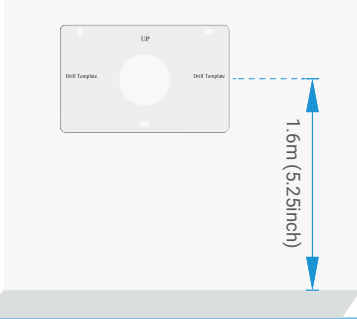

- 2 Take the wires coming from the intercom panel through the holes of the drill template and the wall bracket, then fix the wall bracket with anchors and screws to the wall.

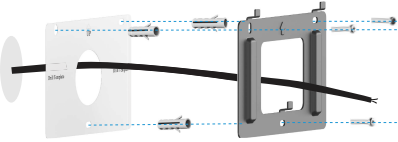

- 3 Connect the wires coming from the intercom panel, and connect the power adapter to the power port in the back of the monitor (without plugging it into the wall outlet).

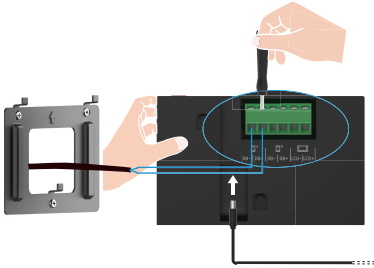

- 4 Place the monitor on the wall bracket.

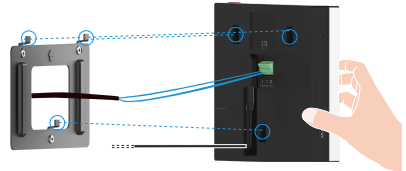

- 5 Restore the electricity at the breaker.

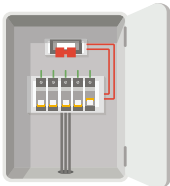

Warning: during this step, do not restore the electricity at the breaker.

Tip: The remaining 4 terminal blocks (DB-+, LCD-+) on the monitor can be left unwired, it will be used for extended in the future.

5. Install the Keypad

5.1. Install Battery

- 1 Remove the battery cover.

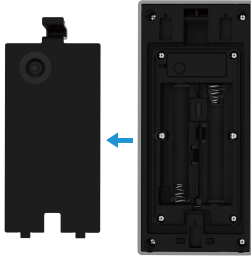

- 2 Install 2*AA-sized batteries (included in the package) into the battery slot, and install the battery cover back.



5.2. Install the Keypad

⚠ Important: When installing the keypad, please make sure that the distance between the keypad and the intercom panel does not exceed 1m.

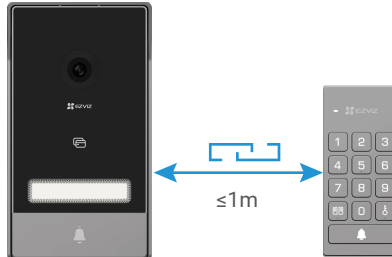

Option A (for smooth wall)

1. Clean the installation location and dry it.
2. Tear off the film of the foam sticker and then paste the wall bracket directly to the desired installation location, and press hard.

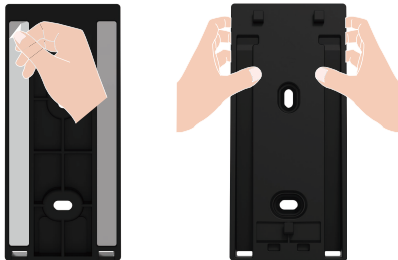

3. Attach the Keypad to the wall bracket, as shown in the figure below.

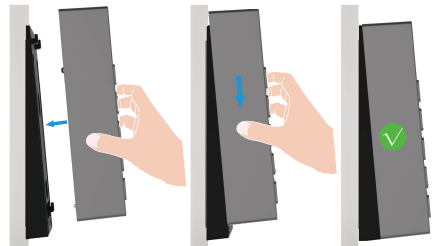

Option B (for uneven wall)

1. Place the drill template onto the surface of the desired installation location, and drill two screw holes.
2. (Optional) Insert anchors to the holes.
3. Secure the mounting bracket using the provided metal screws.

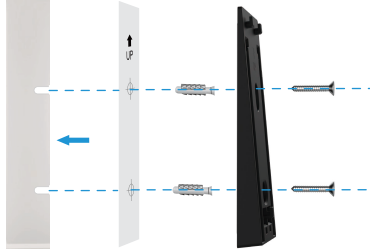

3. Attach the Keypad to the wall bracket, as shown in the figure below.

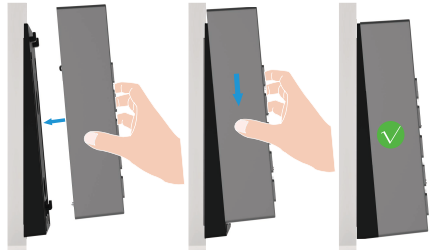

6. Install Micro SD Card (Optional)

1. Insert a micro SD card (purchase separately) into the SD card slot as shown in the figure below.

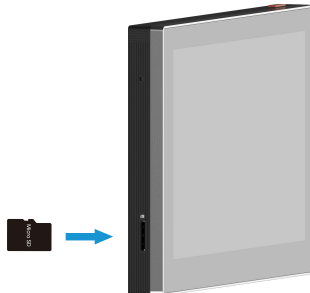

i After installing the micro SD card, you should initialize the card in the EZVIZ app before using it.

2. In the EZVIZ app, tap the Record List in the Device Settings interface to check the SD card status.
3. If the memory card status displays as Uninitialized, tap to initialize it.

i The status will then change to **Normal** and it can store videos.

7. Connect Your EZVIZ Video Doorphone To Your Smartphone

1. Press the "Screen On/Off Button" to turn on the screen.

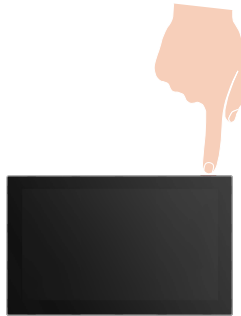

2. Follow the screen wizard to connect the monitor to Wi-Fi (recommended).
3. On your smartphone, log in to your EZVIZ app account, on the Home screen, tap "+" on the upper-right corner to go to the Scan QR Code interface.
4. Scan the QR code on the screen of the monitor.

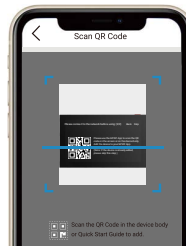
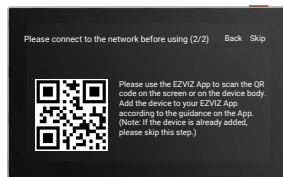

5. Follow the EZVIZ app wizard to add the monitor to the EZVIZ app.

- i** If you failed to connect the monitor to Wi-Fi, or you skip this step (step(1/2) on the monitor), you can choose to use EZVIZ app to finish Wi-Fi configuration:
 - 1) Connect your smartphone to Wi-Fi (suggested)
 - 2) Log in to your EZVIZ app, and scan the QR code on the monitor.
 - 3) Follow the EZVIZ app wizard to finish Wi-Fi configuration and add the video doorphone to your the EZVIZ app.

8. Configure the RFID Badge

1) Add RFID badges:

When turning on the device for the first time, it is essential to configure the badges in the EZVIZ app:

1. Log in to your EZVIZ app account.
2. Go to the Monitor's settings page, choose Card Management > add cards.
3. Set the name of the card, and tap "Next step".
4. Set the term of validity, and tap "Next step".
5. Put the RFID badge on the badge reading zone, the doorbell indicator flash 3 times indicates the badge add successfully.
6. Tap "finish".

2) Delete RFID badges

1. Log in to your EZVIZ app account.
2. Go to the Monitor's settings page, choose Card Management.
3. Tap to choose the card you want to delete, and tap "Delete" -> "OK" to delete the card.

9. Bind the Keypad

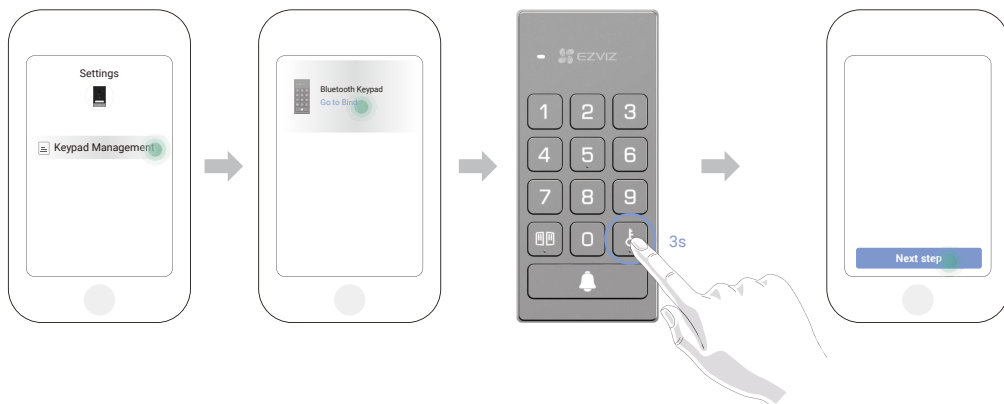

1. Go to the preview page of the intercom panel, and tap Settings->Keypad Management-> Enter Binding to bind the Keypad.
2. Press and hold the  button on the Keypad for 3s, when the LED indicator flashes white, the Keypad entering bind mode.
3. Tap "Next step" to finish binding.



 If you want to unbind the keypad, tap the unbind button at the interface of keypad management.

10. Multiple Unlocking Methods

(1) Open the gate/door via the monitor

1. Go to the main menu on your monitor
2. Tap the  or  to unlock the lock or gate.

(2) Open the gate/door via the EZVIZ App

1. Log in to your EZVIZ app account.
2. Go to the intercom panel live view page, Tap the  or  to unlock the lock or gate.

(3) Open the gate/door with smart RFID badge

• Unlock the the electric strike plate/ Lock:

Quickly swipe your pre-programmed badge on the RFID reading zone. One short beep confirms the opening of the electric strike plate/Lock.

• Unlock the Gate motor:

Hold the badge for at least 3 seconds on the RFID reading zone. One short beep confirms the opening of the gate.

(4) Open the gate/door with QR Code

1. Log in to your EZVIZ app account.
2. Go to the preview page of the intercom panel, Tap "Settings-> Unlocking Settings-> QR code Managment-> Add QR code" to create a QR code, then follow the app wizard to share the QR code to your guset.
3. Then your guest can align the QR code before the lens of the intercom panel, keep the distance of about 10cm, and wait for a few seconds.

(5) Open the gate/door via the Keypad

Press the passcode, and then press the  button or  button to unlock the lock or gate.

 Three short beeps indicates the failure of opening lock/gate.

Maintenance

1. Disassemble the Keypad

- i** If the batteries of the Keypad is run out, you need to disassemble the Keypad off the backplate from the wall, and change the old batteries with new ones.

1. Use the pin provided to press and hold the hole at the bottom of the Keypad, meanwhile take the Keypad off the backplate.

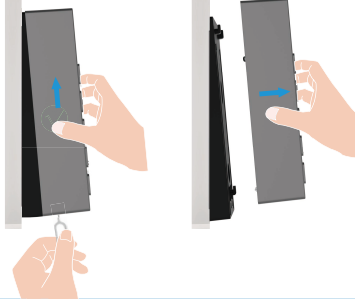

2. Change the Batteries (Optional)

- 1** Remove the battery cover, and the old batteries.

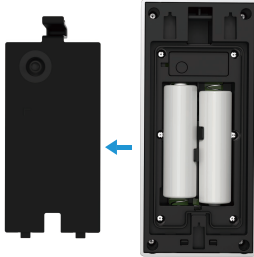

- 2** Install 2*AA-sized batteries into the battery slot, and tighten battery cover.

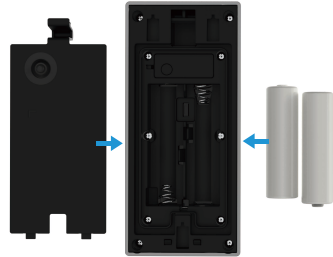

View Your Device on the EZVIZ App

i The app interface may be different due to version update, and the interface of the app you installed on your phone shall prevail.

1. Live View

When you launch the EZVIZ app, the device page displays are shown below. You can view and listen to a live feed, take snapshots, record videos, and choose video definition as needed.

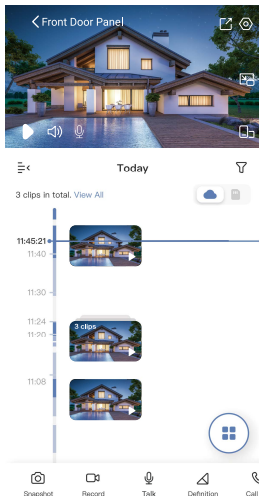

Icon	Description
	Share. Share your device.
	Settings. View or change the device settings.
	Popup. View the video displayed on top of another app you are using.
	Full Screen Display. Tap to enjoy a full screen display for your filed of view.
	Snapshot. Take a snapshot.
	Record. Manually start/stop recording.
	Call Log. View call logs.
	Talk. Tap the icon, and then follow the on-screen instructions to talk to or listen to people in front of the camera.
	Lock. Tap to unlock the electric strike plate or lock.
	Gate. Tap to unlock the gate.
	Definition. Select video resolution from Quad HD, Full HD or Hi-Def.
	Multi-screen Live. Tap to select window layouts.

i Swipe left and right across the screen to see more icons.

2. Settings

2.1 Intercom Panel (Doorbell)

In the settings page, you can set the parameters of the Intercom Panel.

Parameter	Description
Name	View or tap to customize the name of your device here.
Intelligent Detection	You can select between different detection types for your device.
Notification	You can manage the device message and EZVIZ App notification.
Audio Settings	You can set relevant audio parameters for your device.
Image Settings	You can set relevant image parameters for your device.
Light Settings	You can set relevant light parameters for your device.
Card Management	You can manage the badges here.
Cloudplay	You can subscribe and manage the cloud storage.
Record List	You can see the device storage status of the memory card.
Security Settings	You can customize the privacy area here.
Device Information	You can see the device information here.
Share Device	You can share the device to you family member or guest.
Restart Device	Tap to restart the device.

2.2 Monitor

In the settings page, you can set the parameters of the Monitor.

Parameter	Description
Name	View or tap to customize the name of your device here.
Audio Settings	You can set screen ring on/off and choose the doorbell ringtones.
Screen Settings	You can set the screen brightness and auto-lock screen time here.
Record List	You can see the device storage status of the memory card.
Security Settings	You can encrypt your videos with encryption password.
Network Settings	You can see the Wi-Fi name and the connection status.  If you want to change your device's Wi-Fi, please go to the screen, and choose settings-> Network and time-> Current Wi-Fi, and tap to choose the Wi-Fi you want to connect to.
Device Information	You can see the device information here.
Restart Device	Tap to restart the device.
Delete Device	Tap to delete the device from EZVIZ App.

1. Use Amazon Alexa

These instructions will enable you to control your EZVIZ devices with Amazon Alexa. If you run into any difficulties during the process, please refer to **Troubleshooting**.

Before you start, make sure that:

1. EZVIZ devices are connected to the EZVIZ app.
2. In the EZVIZ app, turn off the "Video Encryption" and turn on the "Audio" in the Device Settings page.
3. You have an Alexa-enabled device (i.e Echo Spot, Echo-Show, All-new Echo-Show, Fire TV (all generations), Fire TV stick (second generation only), or Fire TV Edition smart TVs).
4. The Amazon Alexa app is already installed on your smart device, and you have created an account.

To Control EZVIZ devices with Amazon Alexa:

1. Open the Alexa app and select "Skills and Games" from the menu.
2. On the Skills and Games screen, search for "EZVIZ", and you will find "EZVIZ" skills.
3. Select your EZVIZ device's skill, then tap **ENABLE TO USE**.
4. Enter your EZVIZ username and password, and tap **Sign in**.
5. Tap the **Authorize** button to authorize Alexa to access your EZVIZ account, so that Alexa can control your EZVIZ devices.
6. You will see "EZVIZ has been successfully linked", then tap **DISCOVER DEVICES** to allow Alexa to discover all your EZVIZ devices.
7. Go back to Alexa app menu and select "Devices", and under devices you will see all your EZVIZ devices.

Voice Command

Discover a new smart device via the "Smart Home" menu in the Alexa app or the Alexa Voice Control function. Once the device is found, you can control it with your voice. Speak simple commands to Alexa.

Answer the EZVIZ Intercom Panel with Alexa

After you've connected your EZVIZ Intercom Panel to your Alexa-enabled device, you can speak to your visitors through your Echo or Fire TV device.

To speak to your visitor, you can say:

- [Alexa, answer \[EZVIZ Intercom Panel Name\]](#).
- [Alexa, talk to \[EZVIZ Intercom Panel Name\]](#).

 Your device's name for example: "show xxxx camera," can be changed in the EZVIZ app. Each time you change the name of the device, you will need to discover the device again to update the name.

Troubleshooting

What should I do if Alexa fails to discover my device?

Check if there are any Internet connecting problems.

Try to restart the smart device and re-discover the device on Alexa.

Why the device's status is "Offline" on Alexa?

Your device might have been disconnected from the network. Restart the smart device and re-discover on Alexa.

Check if your router is connected to the Internet and try again.

 For details about countries where Amazon Alexa is available, see Amazon Alexa's official website.

2. Use Google Assistant

With the Google Assistant, you can activate your EZVIZ device and watch live by speaking Google Assistant voice commands.

The following devices and apps are required:

1. A functional EZVIZ app.
2. In the EZVIZ app, turn off the "Video Encryption" and turn on the "Audio" in the Device Settings page.
3. A TV with functional Chromecast connecting to it.
4. The Google Assistant app on your phone.

To get started, follow the steps below:

1. Set up the EZVIZ device and make sure it works properly on the app.
2. Download the Google Home app from the App Store or Google Play Store™ and log into your Google account.
3. On the Myhome screen, tap "+" on the upper-left corner, and select "Set up device" from the menu list to go to the Set up interface.
4. Tap **Works with Google**, and search for "EZVIZ", where you will find "EZVIZ" skills.
5. Enter your EZVIZ username and password, and tap **Sign in**.
6. Tap the **Authorize** button to authorize Google to access your EZVIZ account, so that Google can control your EZVIZ devices.
7. Tap **Return to app**.
8. Follow the above steps to complete the authorization. When synchronization is completed, EZVIZ service will be listed under your list of services. To see a list of compatible devices under your EZVIZ account, tap on the EZVIZ service icon.
9. Now try some commands. Use the name of the camera that you created when you set up the system.

Users can manage devices as a single entity or in a group. Adding devices to a room allows users to control a group of devices at the same time using one command.

See the link for more information:

<https://support.google.com/googlehome/answer/7029485?co=GENIE.Platform%3DAndroid&hl=en>

 For additional information about the device, please refer to www.ezviz.com/eu.

SAFETY PRECAUTIONS

Any damage caused by a failure to adhere to the manual shall void the warranty. We assume no liability for damages resulting therefrom!

We cannot be held responsible for any damage to property or persons caused by incorrect use or a failure to adhere to the safety instructions.

This product has been manufactured in full compliance with safety instructions. In order to maintain this status and get the most out of the product, users must adhere to the safety instructions and warnings contained in this manual.



: This symbol indicates that there is a risk of electric shock or short-circuit.

- You should only use this product with a voltage between: 100-240 Volts and 50-60 hertz.
 - Never attempt to use this device with a different voltage.
 - Ensure that all the system's electrical connections conform to the instructions for use.
 - In commercial establishments, ensure that you adhere to the electrical installation accident prevention regulations.
 - In schools, training facilities, workshops, etc. qualified personnel must be on hand to monitor electronic equipment operation.
 - You must follow the instructions for use of any other devices connected to the system.
 - Please contact an experienced person if you have any doubts regarding equipment operation or safety.
 - Never plug in or unplug electrical equipment with wet hands.
 - When installing this product, check that the power supply cables are not at risk of being damaged.
 - Never replace damaged electrical cables yourself! In this case, remove them and call an expert.
 - The mains supply should be located close to the device and must be easily accessible.
 - A switching device (a switch disconnecter, circuit breaker or equivalent device) must be easily accessible and integrated into the installation of the building wiring for equipment which is permanently connected to the network.
 - To ensure the device has sufficient ventilation, keep the area around the device unobstructed.
 - Ventilation should not be blocked by covering the ventilation opening with an object such as a newspaper, tablecloth or curtain, etc).
 - No open flame sources, such as lit candles, should be placed on the device.
 - Comply with the product's operating temperature.
 - The device should not be exposed to running or splashing liquid and no object filled with liquid should be placed on the device.
- Initiatives on the Use of Video Products

Initiatives on the Use of Video Products

Thank you for choosing EZVIZ products.

Technology affects every aspect of our life. As a high-tech company, we are increasingly aware of the role technology plays in improving business efficiency and quality of life, but at the same time, the potential harm of its improper usage. For example, video products are capable of recording real, complete and clear images. This provides a high value in retrospect and preserving real-time facts. However, it may also result in the infringement of a third party's legitimate rights and interests if improper distribution, use and/or processing of video data takes place. With the philosophy of "Technology for the Good", EZVIZ requests that every end user of video technology and video products shall comply with all the applicable laws and regulations, as well as ethical customs, aiming to jointly create a better community.

Please read the following initiatives carefully:

1. Everyone has a reasonable expectation of privacy, and the installation of video products should not be in conflict with this reasonable expectation. Therefore, a warning notice shall be given in a reasonable and effective manner and clarify the Doorbelling range, when installing video products in public areas. For non-public areas, a third party's rights and interests shall be evaluated when installing video products, including but not limited to, installing video products only after obtaining the consent of the stakeholders, and not installing highly-invisible video products.
2. The purpose of video products is to record real activities within a specific time and space and under specific conditions. Therefore, every user shall first reasonably define his/her own rights in such specific scope, in order to avoid infringing on a third party's portraits, privacy or other legitimate rights.
3. During the use of video products, video image data derived from real scenes will continue to be generated, including a large amount of biological data (such as facial images), and the data could be further applied or reprocessed. Video products themselves could not distinguish good from bad regarding how to use the data based solely on the images captured by the video products. The result of data usage depends on the method and purpose of use of the data controllers. Therefore, data controllers shall not only comply with all the applicable laws and regulations and other normative requirements, but also respect international norms, social morality, good morals, common practices and other non-mandatory requirements, and respect individual privacy, portrait and other rights and interests.
4. The rights, values and other demands of various stakeholders should always be considered when processing video data that is continuously generated by video products. In this regard, product security and data security are extremely crucial. Therefore, every end user and data controller, shall undertake all reasonable and necessary measures to ensure data security and avoid data leakage, improper disclosure and improper use, including but not limited to, setting up access control, selecting a suitable network environment (the Internet or Intranet) where video products are connected, establishing and constantly optimizing network security.
5. Video products have made great contributions to the improvement of social security around the world, and we believe that these products will also play an active role in more aspects of social life. Any abuse of video products in violation of human rights or leading to criminal activities are contrary to the original intent of technological innovation and product development. Therefore, each user shall establish an evaluation and tracking mechanism of their product application to ensure that every product is used in a proper and reasonable manner and with good faith.