

COPYRIGHT © Hangzhou EZVIZ Software Co., Ltd. ALL RIGHTS RESERVED.

Any and all information, including, among others, wordings, pictures, graphs are the properties of Hangzhou EZVIZ Software Co., Ltd. (hereinafter referred to as “EZVIZ”). This user manual (hereinafter referred to as “the Manual”) cannot be reproduced, changed, translated, or distributed, partially or wholly, by any means, without the prior written permission of EZVIZ. Unless otherwise stipulated, EZVIZ does not make any warranties, guarantees or representations, express or implied, regarding to the Manual.

### **About this Manual**

The Manual includes instructions for using and managing the product. Pictures, charts, images and all other information hereinafter are for description and explanation only. The information contained in the Manual is subject to change, without notice, due to firmware updates or other reasons. Please find the latest version in the EZVIZ™ website (<http://www.ezviz.com>).

### **Revision Record**

New release – January, 2023

### **Trademarks Acknowledgement**

EZVIZ™, ™, and other EZVIZ’s trademarks and logos are the properties of EZVIZ in various jurisdictions. Other trademarks and logos mentioned below are the properties of their respective owners.

### **Legal Disclaimer**

TO THE MAXIMUM EXTENT PERMITTED BY APPLICABLE LAW, THE PRODUCT DESCRIBED, WITH ITS HARDWARE, SOFTWARE AND FIRMWARE, IS PROVIDED “AS IS”, WITH ALL FAULTS AND ERRORS, AND EZVIZ MAKES NO WARRANTIES, EXPRESS OR IMPLIED, INCLUDING WITHOUT LIMITATION, MERCHANTABILITY, SATISFACTORY QUALITY, FITNESS FOR A PARTICULAR PURPOSE, AND NON-INFRINGEMENT OF THIRD PARTY. IN NO EVENT WILL EZVIZ, ITS DIRECTORS, OFFICERS, EMPLOYEES, OR AGENTS BE LIABLE TO YOU FOR ANY SPECIAL, CONSEQUENTIAL, INCIDENTAL, OR INDIRECT DAMAGES, INCLUDING, AMONG OTHERS, DAMAGES FOR LOSS OF BUSINESS PROFITS, BUSINESS INTERRUPTION, OR LOSS OF DATA OR DOCUMENTATION, IN CONNECTION WITH THE USE OF THIS PRODUCT, EVEN IF EZVIZ HAS BEEN ADVISED OF THE POSSIBILITY OF SUCH DAMAGES.

TO THE MAXIMUM EXTENT PERMITTED BY APPLICABLE LAW, IN NO EVENT SHALL EZVIZ’S TOTAL LIABILITY FOR ALL DAMAGES EXCEED THE ORIGINAL PURCHASE PRICE OF THE PRODUCT.

EZVIZ DOES NOT UNDERTAKE ANY LIABILITY FOR PERSONAL INJURY OR PROPERTY DAMAGE AS THE RESULT OF PRODUCT INTERRUPTION OR SERVICE TERMINATION CAUSED BY: A) IMPROPER INSTALLATION OR USAGE OTHER THAN AS REQUESTED; B) THE PROTECTION OF NATIONAL OR PUBLIC INTERESTS; C) FORCE MAJEURE; D) YOURSELF OR THE THIRD PARTY, INCLUDING WITHOUT LIMITATION, USING ANY THIRD PARTY’S PRODUCTS, SOFTWARE, APPLICATIONS, AND AMONG OTHERS.

REGARDING TO THE PRODUCT WITH INTERNET ACCESS, THE USE OF PRODUCT SHALL BE WHOLLY AT YOUR OWN RISKS. EZVIZ SHALL NOT TAKE ANY RESPONSIBILITIES FOR ABNORMAL OPERATION, PRIVACY LEAKAGE OR OTHER DAMAGES RESULTING FROM CYBER ATTACK, HACKER ATTACK, VIRUS INSPECTION, OR OTHER INTERNET SECURITY RISKS; HOWEVER, EZVIZ WILL PROVIDE TIMELY TECHNICAL SUPPORT IF REQUIRED. SURVEILLANCE LAWS AND DATA PROTECTION LAWS VARY BY JURISDICTION. PLEASE CHECK ALL RELEVANT LAWS IN YOUR JURISDICTION BEFORE USING THIS PRODUCT IN ORDER TO ENSURE THAT YOUR USE CONFORMS TO THE APPLICABLE LAW. EZVIZ SHALL NOT BE LIABLE IN THE EVENT THAT THIS PRODUCT IS USED WITH ILLEGITIMATE PURPOSES. IN THE EVENT OF ANY CONFLICTS BETWEEN THE ABOVE AND THE APPLICABLE LAW, THE LATTER PREVAILS.

# Table of Contents

<b>Overview</b>	<b>1</b>
1. Package Contents	1
2. Basics	2
<b>Get the EZVIZ App</b>	<b>3</b>
<b>Basic wiring diagram</b>	<b>3</b>
<b>Add Your Device to EZVIZ App</b>	<b>4</b>
<b>Device Installation</b>	<b>5</b>
1. Cut the Power Off	5
2. Connect the Wires	6
3. Install the Device	8
<b>Operations on the EZVIZ App</b>	<b>9</b>
1. Wi-Fi Relay Page	9
2. Switch Mode Page	11
3. Motor Mode Page	13
<b>EZVIZ Connect</b>	<b>15</b>
1. Use Amazon Alexa	15
2. Use Google Assistant	16
<b>SPECIFICATION</b>	<b>17</b>
<b>INFORMATION FOR PRIVATE HOUSEHOLDS</b>	<b>18</b>

## Overview

T36 Wi-Fi Relay is a small form factor 2-channel smart switch with power measurement, which allows remote control of electric appliances through a mobile phone, tablet, PC, or home automation system. It can work standalone in a local Wi-Fi network or it can also be operated through cloud home automation services.

It can be accessed, controlled and monitored remotely from any place where the user has internet connectivity, as long as the device is connected to a Wi-Fi router and the Internet.

It can be retrofitted into standard electrical wall boxes, behind power buttons and light switches or other places with limited space.

## 1. Package Contents

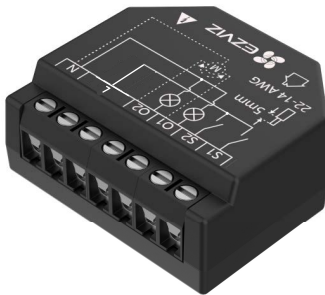

Wi-Fi Relay (x1)



Pin (x1)



Regulatory Information (x1)



Quick Start Guide (x1)

**i** All device's appearances are subject to the one you have bought.

## 2. Basics

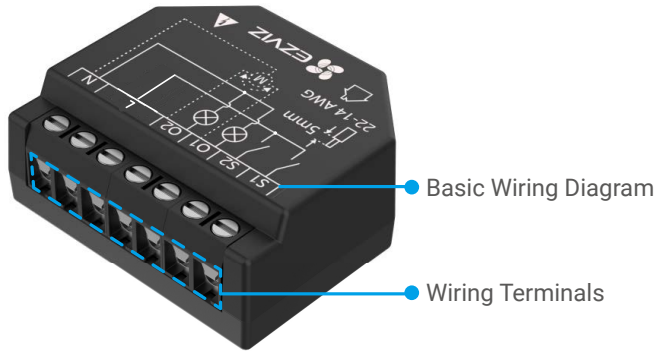

Front View

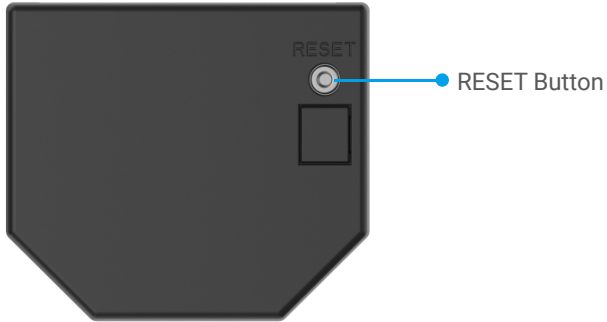

Back View

### \* RESET Button

Use the pin to poke the RESET button for 5s, the device will restore to factory settings.

## Get the EZVIZ App

1. Connect your mobile phone to Wi-Fi (suggested).
2. Download and install the EZVIZ app by searching for “EZVIZ” in the App Store or Google Play™.
3. Launch the app and register an EZVIZ user account.

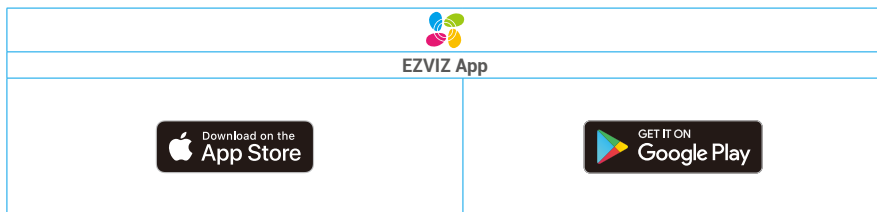

- i** If you have already used the app, please make sure that it is the latest version. To find out if an update is available, go to the app store and search for "EZVIZ".

## Basic wiring diagram

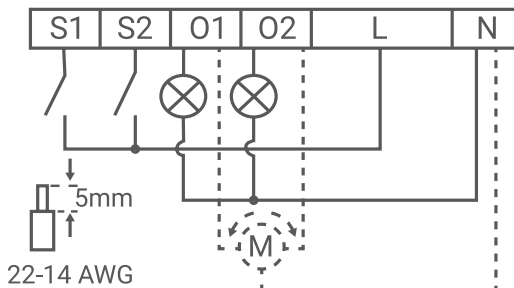

Terminals		Cables	
N	Neutral Terminal	N	Neutral Cable
L	Live(100-240VAC) Terminals	L	Live(100V-240VAC) Cables
O1, O2	Load Circuit Output Terminals		
S1, S2	Switch Input Terminals		

## Add Your Device to EZVIZ App

1. Log in to your account through EZVIZ app, tap the device adding icon and then the QR code scanning interface will be displayed.
2. Scan the QR code on the back of the device or on the cover of the user manual.



3. Add the device by following the wizard on the App.

**i** After adding successfully, the LED indicator of the device will be solid blue.

# Device Installation

- ⚠ • Before installation, make sure that there the cable insulation is not damaged.
- Please make sure that the installation should be performed by a qualified electrician.
- Every change in the connections has to be done after ensuring there is no voltage present at the Device terminals!
- The Device may be connected to and may control electric circuits and appliances only if they comply with the respective standards and safety norms!
- Do not connect the Device to appliances exceeding the given max load!
- Connect the Device only in the way shown in these instructions. Any other method could cause damage and/or injury!
- Do not attempt to service or repair the Device yourself!

## 1. Cut the Power Off

Before mounting the device, turn the circuit breakers off, and use a phase tester or multimeter to check whether there is no voltage on their terminals.

- i You can only proceed to mount and wire the device when you are sure that there is no voltage on the device.

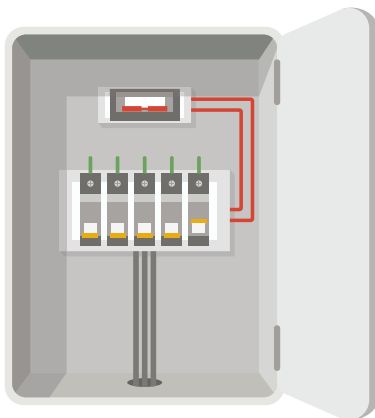

## 2. Connect the Wires

As a cover controller, the device can work in 2 modes: detached mode or dual input mode.

In detached mode, the device can be controlled through EZVIZ App only. Even if buttons or switches are connected to the device, they will not be allowed to control the motor rotation in detached mode.

### For Switch Mode

#### Detached Mode

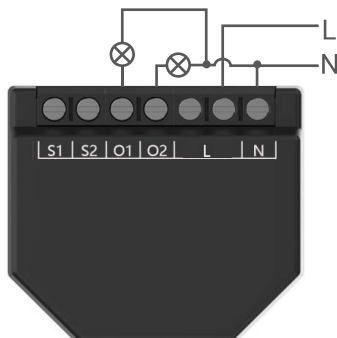

1. Connect both L terminals to the Live cable and the N terminal to the Neutral cable.
2. Connect the first load circuits to the O1 terminal and the Neutral cable. Connect the second load circuits to the O2 terminal and the Neutral cable.

#### Dual Input Mode

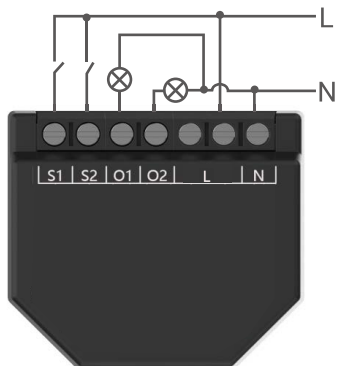

1. Connect both L terminals to the Live cable and the N terminal to the Neutral cable.
2. Connect the first load circuits to the O1 terminal and the Neutral cable. Connect the second load circuits to the O2 terminal and the Neutral cable.
3. Connect the first button/switch to the S1 terminal and the Live cable. Connect the second button/switch to the S2 terminal and the Live cable.

- If the input is configured as a button in the Device Settings, each button press cycles open, close, open, close...
- If the input is configured as a switch in the Device Settings, each switch toggle cycles open, close, open, close...



## For Motor Mode

### Detached Mode

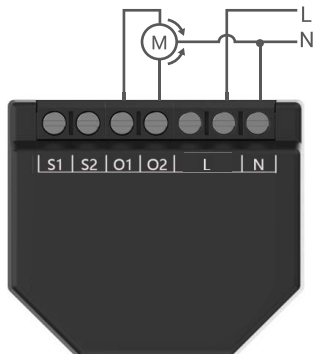

1. Connect both L terminals to the Live cable and the N terminal to the Neutral cable.
2. Connect the common motor terminal/cable to the Neutral cable. Connect motor direction terminals/cables to the O1 and O2 terminals.

### Dual Mode

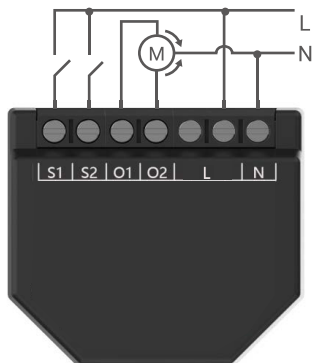

1. Connect both L terminals to the Live cable and the N terminal to the Neutral cable.
2. Connect the common motor terminal/cable to the Neutral cable. Connect motor direction terminals/cables to the O1 and O2 terminals.
3. Connect the first button/switch to the S1 terminal and the Live cable. Connect the second button/switch to the S2 terminal and the Live cable.

#### **i** In case the inputs are configured as buttons:

- Pressing a button when the motor is static, rotate the motor in the corresponding direction until the endpoint is reached.
- Pressing the button for the same direction while the motor is rotating, stops the it.
- Pressing the button for the opposite direction, while the cover is rotating, reverses the cover movement until the endpoint is reached.

#### **i** In case the inputs are configured as switches:

- Turning a switch on moves the motor in the corresponding direction until an endpoint is reached. Turning the switch off stops the motor rotation.
- If both switches are turned on, the Device will respect the last engaged switch. Turning off the last engaged switch stops the motor rotation, even if the other switch is still on.
- To rotate the motor in the opposite direction, the other switch has to be turned off and on again.

### 3. Install the Device

After the wiring is finished, install the device behind the switch or button by referring to the following figure, and then use a screwdriver to tighten the switch or button, and the installation is completed.





# Operations on the EZVIZ App

**i** The App interface may be different due to version update, and the interface of the App you installed on your phone shall prevail.

## 1. Wi-Fi Relay Page

When you launch the EZVIZ app, you can manage your device as needed.



Icon	Description
	Settings. View or change the device settings.
	Switch Mode. Tap to enter detailed page for switch mode. For detailed information, please refer the following <a href="#">Switch Mode Page</a> .
	Motor Mode. Tap to enter detailed page for motor mode. For detailed information, please refer the following <a href="#">Motor Mode Page</a> .

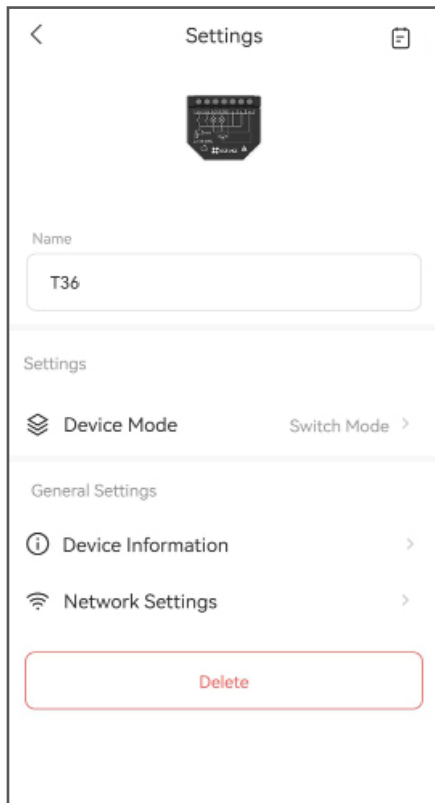

Parameter	Description
Device Name	Customize the name of your device.
Device Mode	Select device mode for your device.
Device Information	You can see the device information here.
Network Settings	View the Wi-Fi your device connected.
Delete	Tap to delete the device from EZVIZ App.

## 2. Switch Mode Page

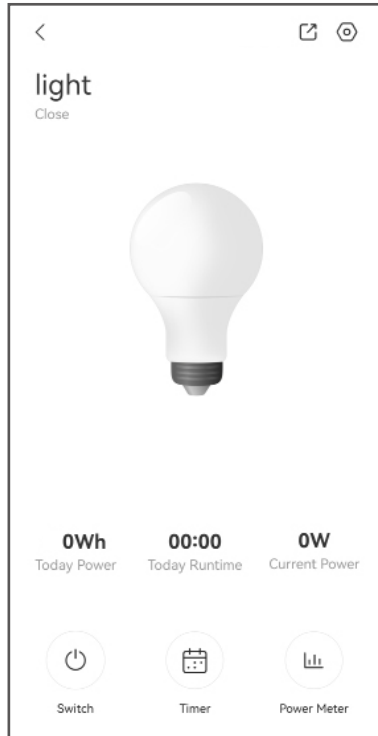

Icon	Description
------	-------------



Share. Share your device with anyone you want.



Settings. View or change the device settings.



Switch. Tap to Open/close the light.



Timer. Tap to set a scheduled plan.



Power Meter. Tap to view the power meter.

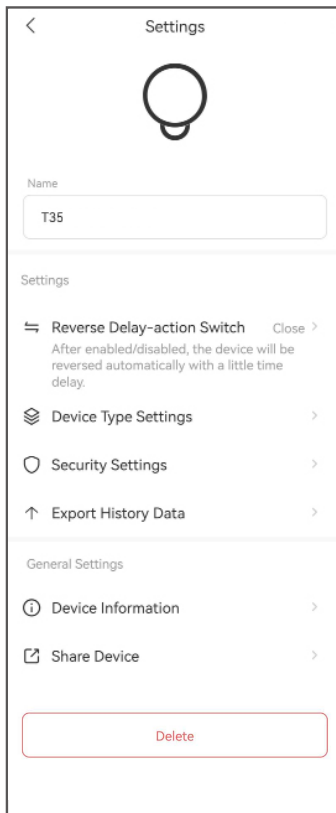

Parameter	Description
Device Name	Customize the name of your device.
Reverse Delay-action Switch	The device will be reversed automatically with a little time delay.
Device Type Settings	Set device input type and related parameters.
Security Settings	Set power protection, voltage protection, current protection and the max value of them.
Export History Data	Tap to export history data to your email box.
Device Information	You can see the device information here.
Share Device	You can share the device to your family members or guests.
Delete	Tap to delete the gateway from EZVIZ App.

### 3. Motor Mode Page



Icon	Description
------	-------------



Share. Share your device with anyone you want.



Settings. View or change the device settings.



Forward. Tap to control the motor to rotate forward.



Reverse. Tap to control the motor to reverse.



Pause. Tap to pause the rotation of the motor.



Timer. Tap to set a scheduled plan.

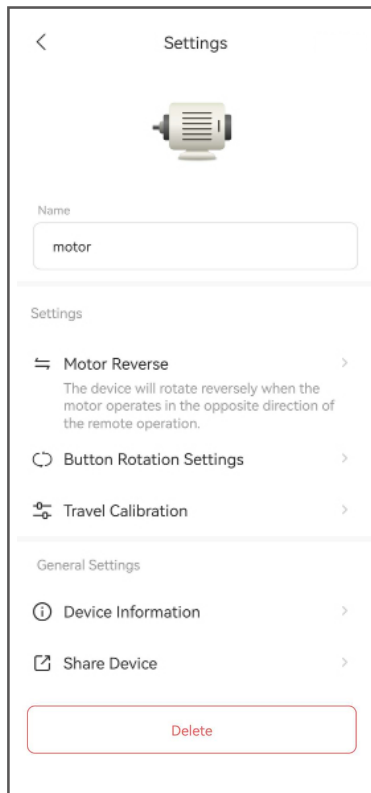

Parameter	Description
Device Name	Customize the name of your device.
Motor Reverse	Tap to reverse the operation direction of the motor.
Button Rotation Settings	Set the execute operations for two buttons.
Travel Calibration	The motor will calibrate once with one auto-rotation.
Device Information	You can see the device information here.
Share Device	You can share the device to your family members or guests.
Delete	Tap to delete the device from EZVIZ App.



## 1. Use Amazon Alexa

These instructions will enable you to control your EZVIZ devices with Amazon Alexa. If you run into any difficulties during the process, please refer to **Troubleshooting**.

### Before you start, make sure that:

1. EZVIZ devices are connected to the EZVIZ app.
2. In the EZVIZ app, turn off the "Video Encryption" and turn on the "Audio" in the Device Settings page.
3. You have an Alexa-enabled device (i.e Echo Spot, Echo-Show, All-new Echo-Show, Fire TV (all generations), Fire TV stick (second generation only), or Fire TV Edition smart TVs).
4. The Amazon Alexa app is already installed on your smart device, and you have created an account.

### To Control EZVIZ devices with Amazon Alexa:

1. Open the Alexa app and select "Skills and Games" from the menu.
2. On the Skills and Games screen, search for "EZVIZ", and you will find "EZVIZ" skills.
3. Select your EZVIZ device's skill, then tap **ENABLE TO USE**.
4. Enter your EZVIZ username and password, and tap **Sign in**.
5. Tap the **Authorize** button to authorize Alexa to access your EZVIZ account, so that Alexa can control your EZVIZ devices.
6. You will see "EZVIZ has been successfully linked", then tap **DISCOVER DEVICES** to allow Alexa to discover all your EZVIZ devices.
7. Go back to Alexa app menu and select "Devices", and under devices you will see all your EZVIZ devices.

### Voice Command

Discover a new smart device via the "Smart Home" menu in the Alexa app or the Alexa Voice Control function.

Once the device is found, you can control it with your voice. Speak simple commands to Alexa.

-  Your device's name for example: "show xxxx camera," can be changed in the EZVIZ app. Each time you change the name of the device, you will need to discover the device again to update the name.

### Troubleshooting

What should I do if Alexa fails to discover my device?

Check if there are any Internet connecting problems.

Try to restart the smart device and re-discover the device on Alexa.

Why the device's status is "Offline" on Alexa?

Your device might have been disconnected from the network. Restart the smart device and re-discover on Alexa.

Check if your router is connected to the Internet and try again.

-  For details about countries where Amazon Alexa is available, see Amazon Alexa's official website.

## 2. Use Google Assistant

With the Google Assistant, you can activate your EZVIZ device and watch live by speaking Google Assistant voice commands.

### **The following devices and apps are required:**

1. A functional EZVIZ app.
2. In the EZVIZ app, turn off the "Video Encryption" and turn on the "Audio" in the Device Settings page.
3. A TV with functional Chromecast connecting to it.
4. The Google Assistant app on your phone.

### **To get started, follow the steps below:**

1. Set up the EZVIZ device and make sure it works properly on the app.
2. Download the Google Home app from the App Store or Google Play Store™ and log into your Google account.
3. On the Myhome screen, tap "+" on the upper-left corner, and select "Set up device" from the menu list to go to the Set up interface.
4. Tap **Works with Google**, and search for "EZVIZ", where you will find "EZVIZ" skills.
5. Enter your EZVIZ username and password, and tap **Sign in**.
6. Tap the **Authorize** button to authorize Google to access your EZVIZ account, so that Google can control your EZVIZ devices.
7. Tap **Return to app**.
8. Follow the above steps to complete the authorization. When synchronization is completed, EZVIZ service will be listed under your list of services. To see a list of compatible devices under your EZVIZ account, tap on the EZVIZ service icon.
9. Now try some commands. Use the name of the camera that you created when you set up the system.

Users can manage devices as a single entity or in a group. Adding devices to a room allows users to control a group of devices at the same time using one command.

See the link for more information:

<https://support.google.com/googlehome/answer/7029485?co=GENIE.Platform%3DAndroid&hl=en>

 Amazon Alexa and Google Assistant are not available for the device under Motor mode.

## SPECIFICATION

Parameters	Descriptions
Product Size(H*W*D)	43.8 ×38.5 ×18.5mm
Power Supply	100-240 VAC, 50/60 Hz
Power Metering	Support
Electrical Consumption	<1.5W
Working Temperature	-10°C - 45°C
Controlling Elements	2 relays
Controlled Elements	2 circuits or a bi-directional AC motor
Max Switching Voltage	250V AC
Max Cuurent Per Channel	10A
Total Max Current	16A
Wi-Fi	Support
Radio Protocol	Wi-Fi 802.11b/g/n

## INFORMATION FOR PRIVATE HOUSEHOLDS

1. Separate collection of waste equipment: Electrical and electronic equipment that has become waste is referred to as waste equipment. Owners of waste equipment must dispose of it separately from unsorted municipal waste. In particular, waste equipment does not belong in household waste, but in special collection and return systems.

2. Batteries and rechargeable batteries as well as lamps: Owners of waste equipment shall, as a rule, separate waste batteries and rechargeable batteries that are not enclosed in the waste equipment, which can be removed from the waste equipment without being destroyed, from the waste equipment before handing them in at a collection point. This does not apply if waste equipment is prepared for reuse with the participation of a public waste management authority.

3. Options for returning waste equipment: Owners of waste equipment from private households can return it free of charge to the collection points of the public waste management authorities or to the take-back points set up by manufacturers or distributors within the meaning of the Electrical and Electronics Equipment Law. Stores with a sales area of at least 400 m<sup>2</sup> for electrical and electronic equipment and those grocery stores with a total sales area of at least 800 m<sup>2</sup> that offer electrical and electronic equipment several times a year or on a permanent basis and make it available in the market are required to take it back. This also applies in the case of distribution using means of distance communication, if the storage and shipping areas for electrical and electronic equipment are at least 400 m<sup>2</sup> or the total storage and shipping areas are at least 800 m<sup>2</sup>. Distributors shall, in principle, ensure take-back by providing suitable return facilities at a reasonable distance from the respective end user. The possibility of returning waste equipment free of charge exists for distributors who are obliged to take it back, among other things, if a new similar device that essentially fulfills the same functions is delivered to an end user.

4. Privacy Notice: Waste equipment often contains sensitive personal data. This applies in particular to devices of information and telecommunications technology such as computers and smartphones. In your own interest, please note that each end user is responsible for deleting the data on the waste equipment to be disposed of.

5. Meaning of the symbol “crossed-out wheelee bin”: The symbol of a crossed-out wheelee bin regularly depicted on electrical and electronic equipment indicates that the respective device is to be collected separately from unsorted municipal waste at the end of its service life.