

*Since 1968*

**COMMAX**  
SmartHome & Security

# User Manual

WDP-174LM / WDR-174DS



[www.commax.com](http://www.commax.com)

COMMAX Co.,Ltd.



- Thank you for purchasing COMMAX products.
- Please carefully read this User's Guide (in particular, precautions for safety) before using a product and follow instructions to use a product exactly.
- The company is not responsible for any safety accidents caused by abnormal operation of the product.



## Contents

1. Introduction .....	2
2. Important Safeguard .....	3
3. Part names and Functions .....	4
4. Configuration.....	6
5. Wiring .....	7
6. Pairing / Unpairing Method.....	7
7. How to use .....	9
8. Installation .....	10
9. Specifications and Features .....	12
10. Accessory.....	13



## 1. Introduction

Your unit is designed so it can be flush mounted on the wall or used. When flush mounted on the wall, the stand permits you to view the unit for an angular view. The model number is located on the bottom and record the serial number in the space provided below (available). Refer to these numbers whenever you call upon your COMMAX dealer regarding this product.

Model No. \_\_\_\_\_

Serial No. \_\_\_\_\_

**To prevent fire or shock hazard, do not expose the unit to rain or moisture.**



This symbol is intended to alert the user to the presence of uninsulated **"dangerous Voltage"** within the product's enclosure that may be of sufficient magnitude to constitute a risk of electric shock to persons.



This symbol is intended to alert the user to the presence of important operating and maintenance (servicing) instructions in the literature accompanying the appliance.



**caution**

Risk of electric shock  
do not open



**CAUTION :** To reduce the risk of electric shock, do not remove cover (or back) no user-serviceable part inside refer servicing to qualified service personnel



## 2. Important Safeguards

- ▲ **Damage Requiring Service:** This equipment from the power source and source and refer servicing to qualified service personnel under the following conditions:
  - ① when the power is damaged.
  - ② if liquid has been spilled or objects have fallen into the unit
  - ③ if the equipment has been exposed to rain or water.
  - ④ if the equipment has been dropped or otherwise damaged.
  - ⑤ when the equipment exhibits a distinct change in performance- this indicates a need for service.
- ▲ **Water and Moisture:** Do not use this product near water, for example, near a bath tub, wash bowl, kitchen sink, or laundry tub, in a wet basement, or near a swimming pool, and the like.
- ▲ **Accessories:** The product may fall, causing serious injury to a child or adult, and serious damage to the appliance. Any mounting of the manufacture's instructions, and should use a mounting accessory recommended by the manufacturer.
- ▲ **Object and Liquid Entry:** Never push objects of any kind into this product through openings as they may touch dangerous voltage points or short-out parts that could result in a fire or electric shock. Never spill liquid of any kind on the product.
- ▲ **Lightning:** For added protection for this product before a lightning storm, or when it is left un attached and un used for long periods of time, unplug it from the wall outlt and disconnect the other system. This will prevent damage to the product due to lightning and power-line surges. If you live in an area heavily prone to lightning storms, it is recommended that you invest in power-line, telephone-line, RFcable and actuator/ polarization surge protectors to protect your appliance system from possible damage



### 3. Part names and Functions

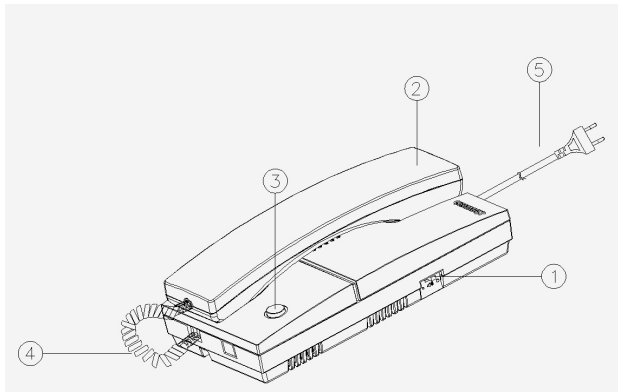

Item	Function
①	Power
②	Handset
③	Door Release Button
④	Cord
⑤	Power plug

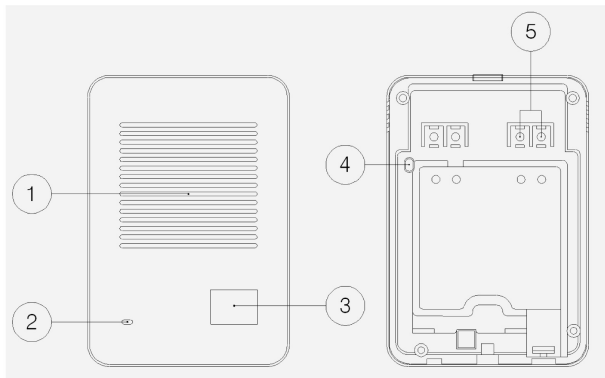

Item	Function
①	Speaker
②	Microphone
③	Paging button
④	Door release terminal
⑤	Power terminal (2-wire with non-polarity)



## 4. Configuration

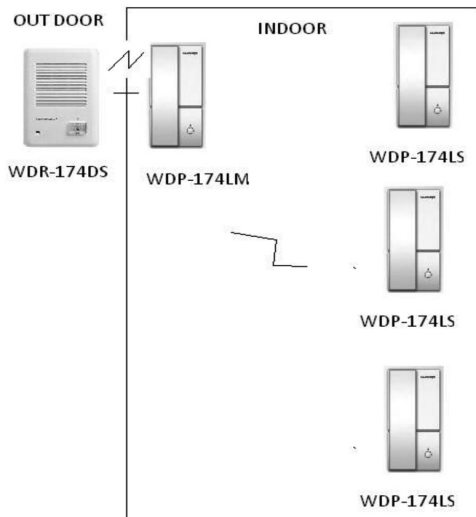



## 5. Wiring

- Interphone : Plug in the AC power cord.
- Door unit : Connect DC 12V(non-polarity) to 5 in Page 5.  
Connect 2 wires from a door release to 4.



## 6. Pairing / Unpairing Method

### A. Paring

- 1) There are three devices, one is WDP-174LM (main unit) WDP-174LS(sub unit) and WDR-174DS (sub unit).
- 2) There will be a sound of triple beep as powered on.
- 3) pairing WDP-174LM & WDR-174DS

First power on a main unit with the handset off the hook. Within 30 seconds, press the paging button for duration of 5 seconds. With a sound of beep the main unit is in pairing mode for 60 seconds.

Secondly, power on a sub unit(WDR-174DS) with DC 12V. Within 15 seconds, press the paging button for duration of 5 seconds. With a sound of beep the sub unit is in pairing mode. While the main and sub units are in pairing mode, there will be a double beep sound to indicate the pairing process start and another triple beep to indicate the completion.

After paring is completed, press the paging button to test.



#### 4) pairing WDP-174LM & WDP-174LS

First power on a main unit with the handset off the hook. Within 30 seconds, press the paging button for duration of 5 seconds. With a sound of beep the main unit is in pairing mode for 60 seconds.

Secondly. Sub unit(WDP-174LS) to action in the same way as main unit While the main and sub units are in pairing mode, there will be a double beep sound to indicate the pairing process start and another triple beep to indicate the completion.

#### 5) Once the pairing is completed, there will be a triple beep to indicate the successful connection between the main and sub units every time the power is turned off and back on.

\* If pairing failed, only the sub unit will make a beep sound.

### **B. Delete pairing**

#### 1) Main unit (WDP-174LM)

Power on with a handset off the hook. Within 30 seconds press the paging button for three short times and the fourth time for the duration of 5 seconds. There will be a beep sound to indicate the pairing is deleted.

After deletion is done, there will be a triple beep sound. Please turn the power off and back on to complete the process.

#### 2) Sub unit(WDP-174LS)

Same as Main unit

### 3) Sub unit (WDR-174DS)

After powered on (DC12V), within 15 seconds press the paging button for three short times and the fourth time for the duration of 5 seconds. All main units registered will be deleted with a sound of triple beep. Please turn the power off and back on to complete the process.



## 7. How to use

- 1) Press the paging button from the sub unit (WDR-174DS).
- 2) There will be a paging tone ringing at the main unit (WDP-174LM). and sun unit(WDP-174LS)
- 3) Pick up the handset to talk.(WDP-174LM/S)
- 4) Press the door release button while talking to release the door.
  - a door release function only works while in talking mode between the main and sub unit and after the door is released the call is automatically disconnected.
- 5) Place the handset on the hook to hang up.
- 6) Turn on the unit and after 30seconds press the call button for 5 seconds while the handset is hung on its hook lever. When the call button is clicked the bell changes in order of 1→2→3→2→1

## 8. Installation

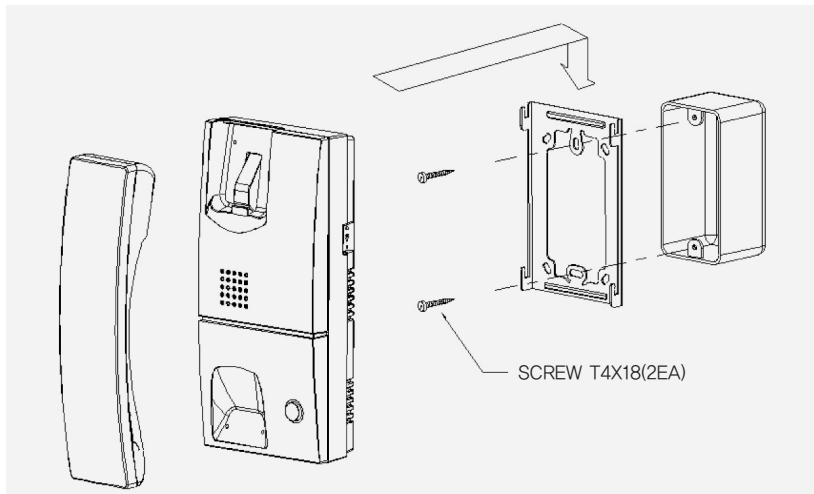

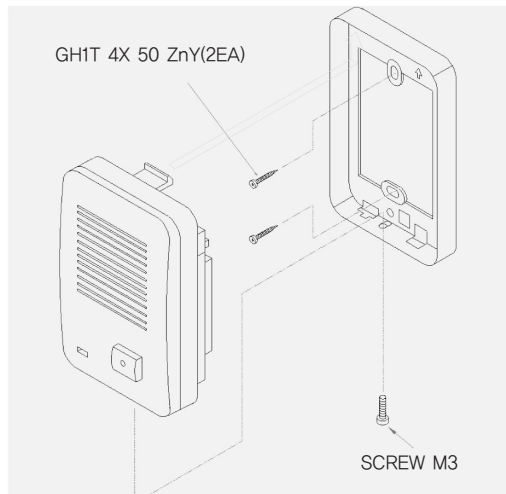



## 9. Specifications and Features

Item	Contents(WDP-174LM/S,WDR-174DS)
Power	WDP-174LM/S : 110V~ / 60HZ 220V~ / 50~60HZ 230V~ / 50~60HZ
	WDR-174DS : DC 12V $\equiv$
Power Consumption	WDP-174LM : 2W
	WDP-174LS / WDR-174DS : 1W
Frequency	GFSK
Paging tone	Electronic chime Outdoor open area : 200 meters Indoor : 40~50 meters
Operating Temperature	0°C ~ +40°C
Dimension	WDP-174LM/S : except handset : 107 x 195 x 38mm including handset : 107 x 195 x 51mm
	WDR-174DS : 91 x 134 x 22mm

- ※ The effective range of wireless devices can vary depending on the environment, especially around elevator or high voltage cables. A metal gate or wall can also affect it and shorten the range.
- ※ Wireless devices have a built-in antenna and the direction of the device placed on a desk or mounted on a wall may cause a minor noise during vocal communication.



## 10. Accessory

WDP-174LM

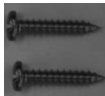

Screws for wall mount : 2 Ea.



Bracket



screw for powercord

WDR-174DS



Screws for wall mount : 2 Ea



Product fixing screw : 1 Ea.

# **COMMAX**

**COMMAX Co.,Ltd.**

513-11, Sangdaewon-dong, Jungwon-gu, Seongnam-si, Gyeonggi-do, Korea  
Int'l Business Dept. : Tel.; +82-31-7393-540~550 Fax.; +82-31-745-2133  
Web site : [www.commax.com](http://www.commax.com)

*PM14WPR17410*

*Printed In Korea / 2014.04.105*