

WP8010/WP8030

Version 18

Installer's Guide

Table of Contents

<p>1. INTRODUCTION 3</p> <p> 1.1 System Features 3</p> <p>2. CHOOSING THE INSTALLATION LOCATION .. 6</p> <p>3. WP8010 INSTALLATION..... 8</p> <p> 3.1 Opening the WP8010 Control Panel and Bracket Mounting..... 8</p> <p> 3.2 Connecting to the Telephone Line..... 9</p> <p> 3.3 System Planning & Programming..... 10</p> <p> 3.4 GSM Module Installation 10</p> <p> 3.5 PGM-5 Installation..... 11</p> <p> 3.6 Adding Wired Zones or PGM Device 12</p> <p> 3.7 Connecting Power to the Control Panel ... 14</p> <p> 3.8 Supplying Power to the Unit 16</p> <p> 3.9 Closing the WP8010 Control Panel..... 16</p> <p>4. WP8010/WP8030 INSTALLATION 17</p> <p> 4.1 WP8030 Wiring Diagram 17</p> <p> 4.2 Opening the WP8010/WP8030 Control Panel and Bracket Mounting 18</p> <p> 4.3 Connecting to the Telephone Line..... 18</p> <p> 4.4 Connecting Wired Zone and Siren..... 19</p> <p> 4.5 System Planning & Programming..... 19</p> <p> 4.6 GSM Module Installation 20</p> <p> 4.7 DUAL RS-232 Optional Module Mounting 21</p> <p> 4.8 PGM-5 Installation..... 21</p> <p> 4.9 Optional Expander Module..... 22</p> <p> 4.10 Connecting Power to the Control Panel. 24</p> <p> 4.11 Battery Insertion..... 26</p> <p> 4.12 Supplying Power to the Unit 26</p> <p> 4.13 Closing the WP8030 Control Panel..... 27</p> <p>5. PROGRAMMING 28</p> <p> 5.1 General Guidance 28</p> <p> 5.1.1 Navigation 28</p> <p> 5.1.2 Feedback Sounds 29</p> <p> 5.2 Entering the "Installer Mode" and Selecting a Menu Option 29</p>	<p> 5.2.1 Entering the "Installer Mode" if "User Permit" is enabled 30</p> <p> 5.2.2 Selecting options 30</p> <p> 5.2.3 Exiting the Installer Mode 30</p> <p> 5.3 Setting Installer Codes..... 30</p> <p> 5.3.1 Identical Installer and Master Installer Codes 31</p> <p> 5.4 Zones / Devices 32</p> <p> 5.4.1 General Guidance & Zones/Devices Menu Options 32</p> <p> 5.4.2 Adding New Wireless Devices or Wired Sensors 32</p> <p> 5.4.3 Deleting a Device 36</p> <p> 5.4.4 Modifying or Reviewing a Device..... 37</p> <p> 5.4.5 Replacing a Device..... 37</p> <p> 5.4.6 Configuring Soak Test Mode 38</p> <p> 5.4.7 Defining Configuration Defaults for "Device Settings" 38</p> <p> 5.4.8 Updating Devices after Exiting Installer Mode 39</p> <p> 5.5 Control Panel 39</p> <p> 5.5.1 General Guidance – "Control Panel" Flow-Chart & Menu Options 39</p> <p> 5.5.2 Configuring Arming/Disarming and Exit/Entry Procedures..... 40</p> <p> 5.5.3 Configuring Zones Functionality 42</p> <p> 5.5.4 Configuring Alarms & Troubles 42</p> <p> 5.5.5 Configuring Sirens Functionality 44</p> <p> 5.5.6 Configuring Audible & Visual User Interface 45</p> <p> 5.5.7 Configuring Jamming and Supervision (Missing device) 46</p> <p> 5.5.8 Configuring Miscellaneous Features... 47</p> <p> 5.6 Communication 48</p> <p> 5.6.1 General Guidance – "Communication" Flow-Chart & Menu Options 48</p> <p> 5.6.2 Configuring PSTN (landline phone) Connection 49</p> <p> 5.6.3 Configuring GSM-GPRS (IP) - SMS Cellular Connection 50</p>
--	--

5.6.4	Configuring Events Reporting to Monitoring Stations	51	7.5	Replacing/Relocating Detectors	78
5.6.5	Configuring Events Reporting to Private Users	55	7.6	Annual System Check	79
5.6.6	Configuring Motion Cameras for Visual Alarm Verification.....	55	8. READING THE EVENT LOG	80	
5.6.7	Configuring Upload / Download Remote Programming Access Permission	56	APPENDIX A. Specifications	81	
5.6.8	Broadband	58	A1. Functional	81	
5.7 PGM Output	58		A2. Wireless	82	
5.7.1	General Guidance	58	A3. Electrical	82	
5.7.2	Open Collector States	58	A4. Communication	84	
5.7.3	PGM Output Configuration	59	A5. Physical Properties	84	
5.7.4	PGM-5 Connection.....	60	A6. Peripherals and Accessory Devices	84	
5.7.5	Entering Daytime Limits	60	APPENDIX B. Working with Partitions.....	86	
5.8 Custom Names	61		B1. User Interface and Operation	86	
5.8.1	Custom Zone Names	61	B2. Common Areas.....	86	
5.8.2	Record Speech	62	APPENDIX C. Detector Deployment & Transmitter Assignments.....	87	
5.8.3	Voice Box Mode	63	C1. Detector Deployment Plan.....	87	
5.9 Diagnostics.....	63		C2. Keyfob Transmitter List	88	
5.9.1	General Guidance – "Diagnostics" Flow-Chart & Menu Options	63	C3. Emergency Transmitter List.....	88	
5.9.2	Testing Wireless Devices	64	C4. Non-Alarm Transmitter List.....	89	
5.9.3	Testing the GSM module	65	APPENDIX D. Event Codes.....	90	
5.9.4	Testing the SIM Number	66	D1. Contact ID Event Codes.....	90	
5.9.5	Testing the Broadband/PowerLink Module	66	D2. SIA Event Codes	90	
5.10 User Settings	66		D3. Understanding the Scancom Reporting Protocol Data Format	91	
5.11 Factory Default	67		D4. SIA over IP - Offset for Device User.....	91	
5.12 Serial Number	67		APPENDIX E. Sabbath Mode	92	
5.13 Partitioning	67		E1. General Guidance.....	92	
5.13.1	General Guidance – "Partitioning" Menu.....	67	E2. Connection	92	
5.13.2	Enabling / Disabling Partitions.....	67	E3. Arming the System by Sabbath Clock.....	92	
5.14 Operation Mode.....	68		APPENDIX F. PowerLink3 IP Communicator, ...	93	
5.14.1	General Guidance – "Operation Mode" Menu.....	68	F1. Getting Started.....	93	
5.14.2	Select setting	68	F2. Specifications	93	
5.14.3	BS8243 Setup.....	68	F3. Installation	94	
5.14.4	DD243 Setup	69	Package Contents	94	
5.14.5	CP01 Setup.....	71	System Requirements	94	
5.14.6	OTHERS Setup.....	72	F4. Installing the DSC PowerLink3 IP Communicator	95	
6. PERIODIC TEST	74		Hardware Installation.....	95	
6.1 General Guidance	74		Control Panel Configuration.....	97	
6.2 Conducting a Periodic Test.....	74		APPENDIX G. Glossary.....	98	
7. MAINTENANCE	77		APPENDIX H. Compliance with Standards	100	
7.1 Handling System Troubles	77		WP8010/WP8030 Quick User Guide	102	
7.2 Dismounting the Control Panel.....	78				
7.3 Replacing the Backup Battery.....	78				
7.4 Fuse Replacement	78				

1. INTRODUCTION

WP8010WP8030 are PowerG-enabled professional all-in-one wireless security, fire and safety systems supporting advanced applications and DSC's new revolutionary PowerG™ Two-Way, Time Division Multiple Access (TDMA) and Frequency Hopping Spread Spectrum (FHSS) wireless technology. This offers unmatched wireless robustness, superior range and long battery life; a perfect and user friendly solution for both monitoring service providers and professional installers.

This manual refers to WP8010/WP8030 and above. The most updated manuals can be downloaded from the DSC Web site <http://www.dsc.com>.

Note: For UL installations, please contact the manufacturer for the most recent version of UL approved documentation. The WP8010/WP8030 control panel is supplied with 2 instruction manuals:

- **Installer's Guide** (this manual) – for use of system installer during system installation and configuration
- **User's Guide** — also for use of system installer during system installation and configuration, but also for the master user of the system, once installation is completed. Hand over this manual to the master user of the system.

1.1 System Features

The following table lists the WP8010/WP8030 features with a description of each feature and how to use it.

<u>Feature</u>	<u>Description</u>	<u>How to configure and use</u>
Visual Alarm Verification	The WP8010/WP8030 when used with PG9934 PIR-camera detector and GPRS communication is able to provide the Monitoring Station with clips captured in alarm situations. The system sends the clips to the Monitoring Station automatically for burglary alarms and, depending on setup, also for fire and personal emergency alarms. Note: WP8010/WP8030 is compatible with the following UL/ULC listed receivers: SG-System I, SG-System III, SG-System IV.	<p>1. Setup GPRS communication: see GSM Module Installation (section 3.4 for WP8010 or section 4.6 for WP8030).</p> <p>2. Configure camera settings: refer to the PG9934 Installation Instructions.</p> <p>3. Enable fire and personal alarm verification: see section 5.6.6 Configuring Motion Cameras for Video Alarm Verification.</p>
On demand clips from cameras	The WP8010/WP8030 can provide images from the PG9934 by demand from a remote PowerManage server. Pictures are taken based on a command from the monitoring station. To protect customers' privacy, the system can be customized to enable the "On Demand View" only during specific system modes (i.e. Disarm, Home & Away) and also to a specific time window following an alarm event.	<p>1. Setup the On demand feature: see section 5.6.6 Configuring Motion Cameras for Video Alarm Verification.</p> <p>2. To request and view images: refer to the PowerManage User's Guide, Chapter 5 Viewing and Handling Events.</p>
Easy Enrollment	PowerG devices are enrolled from the control panel. "Pre-enrollment" can also be performed by entering the PowerG device ID number and then activating the device in the vicinity of the panel.	To enroll or pre-enroll devices: see section 5.4.2 Adding New Wireless Devices or Wired Sensors.
Device Configuration	Device parameters and related system behavior can be configured from the control panel or from a remote location. Each PowerG device has its own settings which can be configured through the control panel by entering the "DEVICE SETTINGS" menu. Note: The minimum configuration of the system includes one detector.	<p>To configure devices from the control panel: see Chapter 5 Programming and also the individual device's Installation Instructions.</p> <p>To configure devices from a remote location: refer to the PowerManage User's Guide Chapter 3 Working with Panels and to the Remote Programmer PC software User's Guide, Chapters 6 and 7.</p>

3. WP8010 INSTALLATION

Diagnostics of the control panel and peripherals	You can test the function of all wireless sensors deployed throughout the protected area, to collect information about the received signal strength from each transmitter and to review accumulated data after the test.	To perform diagnostics and to obtain signal strength indication: see section 5.9 Diagnostics.
Conducting periodic tests	The system should be tested at least once a week and after an alarm. The periodic test can be conducted locally or from a remote location (with the assistance from a non-technical person in the house).	To conduct a walk test locally: see Chapter 6 Periodic Test. To conduct a walk test from remote location: refer to the Remote Programmer PC software User's Guide, Chapter 6 Data Details Tables.
Partitions	The partitioning feature, when enabled, divides your alarm system into distinct areas each of which operates as an individual alarm system. Partitioning can be used in installations where shared security systems are more practical, such as a home office or warehouse building.	1. Enable partitioning: see section 5.13 Partitioning. 2. Setup partition association for each device: see section 5.4.2 Adding New Wireless Devices or Wired Sensors. To understand more about partitioning: see APPENDIX B. Working with Partitions and APPENDIX B. in the User's Guide.
Two-way voice communication ¹	The WP8010/WP8030 system enables voice communication with Monitoring Stations.	To enable and configure two way voice: see section 5.6.4 Configuring Events Reporting to Monitoring Stations.
Device configuration templates	The default parameters with which a new device is enrolled into the system can be set before you enroll devices. This default template saves time on device configuration.	1. Define enrollment defaults for devices: see section 5.4.7 Defining Configuration Defaults for "Device Settings". 2. Enroll or pre-enroll devices: see section 5.4.2 Adding New Wireless Devices or Wired Sensors.
SirenNet - distributed siren using Smoke detectors	All PowerG smoke detectors are able to function as sirens, alerting on any of 4 types of alarm in the system: fire, gas, burglary and flood. Note: For UL installations, smoke detectors alert only upon fire alarm in the system.	Enable and configure SirenNet for each smoke detector: refer to the (PGX926 / PGX916.) Installation Instructions.
Integrated Siren built into the panel	The control panel has a high-powered built-in siren that sounds in case of alarm, enabled by default.	To define whether or not the control panel's siren will sound upon alarms: see section 5.5.5 Configuring Sirens Functionality.
Wired Siren outputs	The control panel can operate a wired siren and strobe devices.	Install and connect wired siren: see section 4.9 Optional Expander Module Mounting.
Wired zones and programmable outputs (PGM)	The control panel can support wired detectors and control automation devices with programmable wired outputs.	1. Connect a wired zone or PGM device: see section 3.6 Adding a Wired Zone or PGM. 2. Program the wired zone: see section 5.4.2 Adding New Wireless Devices or Wired Sensors. 3. Program PGM outputs behavior: see section 5.7 PGM Output.

¹ Refers to WP8030 with voice option only

3. WP8010 INSTALLATION

Reporting to Private Users and/or Monitoring Station by telephone, SMS and IP communication	The WP8010/WP8030 system can be programmed to send notifications of alarm and other events to 4 private telephone subscribers by voice and also to 4 SMS cellular phone numbers and to report these events to the Monitoring Station by SMS, PSTN or IP communication (IP communication not enabled in UL Listed product).	To configure notifications to Private phones: refer to the WP8010/WP8030-User's Guide, Chapter 6, section B.12 Programming Private Phone and SMS Reporting. To configure reporting to the Monitoring Station: see section 5.6.4 Configuring Events Reporting to Monitoring Stations.
Quick installation with link quality indication	With PowerG devices, there is no need to consult the control panel when mounting a wireless device, because PowerG devices include a built-in link quality indicator. Choosing the mounting location is a quick and easy process.	To choose the ideal location to mount a wireless device, see Chapter 2 Choosing the Installation Location.
Device Locator	Helps you to easily identify the actual device displayed on the LCD display.	To read more on the Device Locator: refer to the WP8010/WP8030 User's Guide, Chapter 2, Operating the WP8010/WP8030 System. To use the device locator when bypassing a zone or when clearing a bypassed zone: refer to the WP8010/WP8030 User's Guide, Chapter 6, section B.1 Setting the Zone Bypass Scheme. To use the device locator when conducting the periodic test: see Chapter 6 Periodic Test or refer to the WP8010/WP8030 User's Guide, Chapter 9 Testing the System.
Guard key-safe	WP8010/WP8030 is able to control a safe that holds site keys that are accessible only to the site's guard or Monitoring Station's guard in the event of an alarm.	1. Connect the safe to the panel: see section 3.6 Adding Wired Zones or PGM Device, Figure 3.6b (WP8010) / section 4.9 Optional Expander Module Mounting, Figure 4.9b (WP8030). 2. Configure the safe's zone type to "Guard Zone": see section 5.4.2 Adding New Wireless Devices or Wired Sensors. 3. Setup guard code: see section 5.3 Setting Installer Codes.
Arming Key	External system may control arming and disarming of the WP8010/WP8030 system.	1. Connect the external system output to the panel: see section 3.6 Adding Wired Zones or PGM Device, Figure 3.6b (WP8010) / section 4.9 Optional Expander Module Mounting, Figure 4.9b (WP8030).

Note: Monitoring Station means not evaluated by UL.

3. WP8010 INSTALLATION

System Architecture:

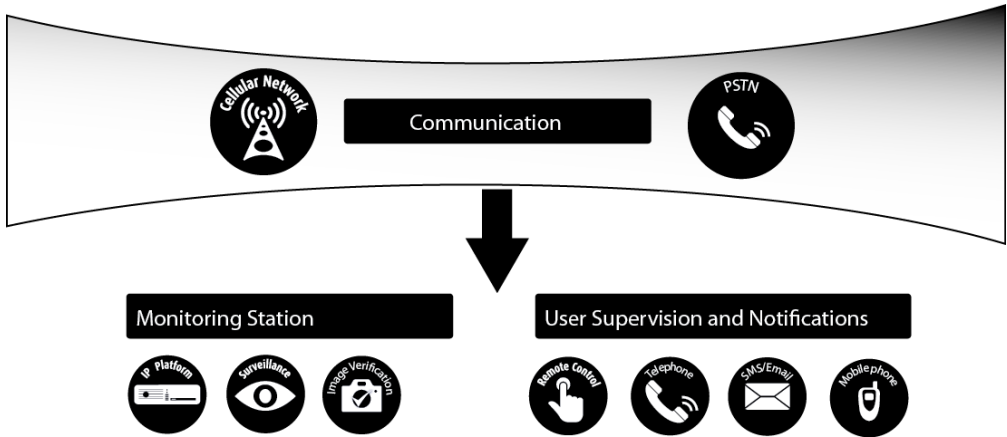
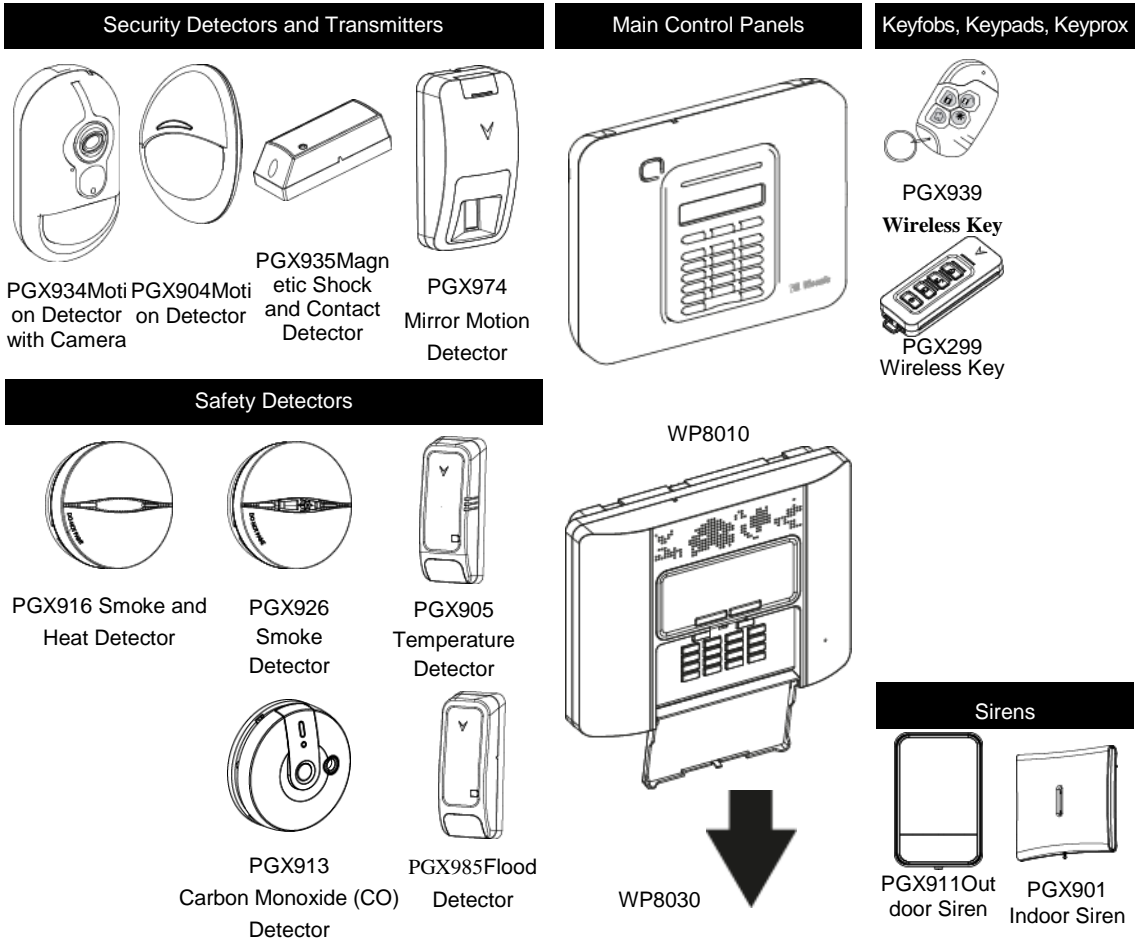

2. CHOOSING THE INSTALLATION LOCATION

To ensure the best possible mounting location of the WP8010/WP8030 control panel, the following points should be observed:

- The selected location should be approximately in the center of the installation site between all the transmitters, preferably in a hidden location.

- In close proximity to an AC source
 - In close proximity to a telephone line connection (if PSTN is used)
 - Where there is good cellular coverage, if GSM-350 PG2 is used
 - Far from sources of wireless interference, such as:
 - Computers or other electronic devices, power conductors, cordless phones, light dimmers, etc.
 - Large metal objects (such as metal doors or refrigerators)
- Note:** A distance of at least 1 meter (3 ft.) is recommended.
- If using the panel's built-in siren and/or voice, select location where audio can be heard throughout the premises.

When mounting wireless devices:

- Make sure that the signal reception level for each device is either "Strong" or "Good", but not "Poor".
- Note:** For UL/cUL installations, the test result must be "Strong" for all wireless devices.
- Wireless magnetic contacts should be installed in a vertical position and as high up the door or window as possible.
 - Wireless PIR detectors should be installed upright at the height specified in their Installation Instructions
 - Repeaters should be located high on the wall in mid-distance between the transmitters and the control panel.

WARNING! To comply with FCC and IC RF exposure compliance requirements, the control panel should be located at a distance of at least 20 cm from all persons during normal operation. The antennas used for this product must not be co-located or operated in conjunction with any other antenna or transmitter.

Customer Premises Equipment and Wiring

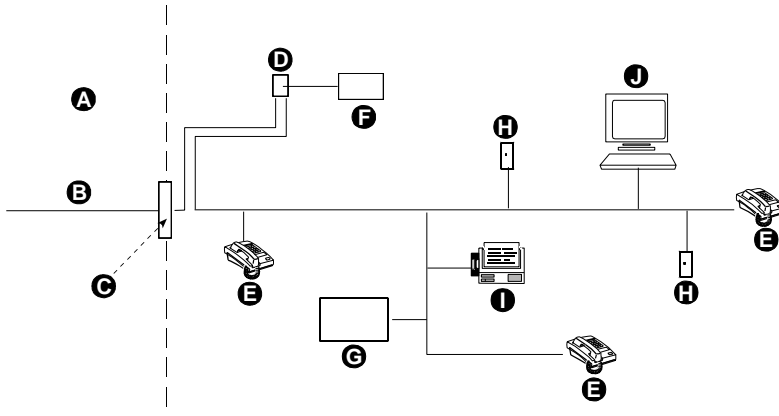

- | | |
|---|--|
| <ul style="list-style-type: none"> A. Network Service Provider's Facilities B. Telephone Line C. Network Demarcation Point D. RJ-31X Jack E. Telephone | <ul style="list-style-type: none"> F. Alarm Dialing Equipment G. Answering System H. Unused RJ-11 Jack I. Fax Machine J. Computer |
|---|--|

Note: The REN is used to determine the number of devices that may be connected to a telephone line. Excessive RENs on a telephone line may result in the devices not ringing in response to an incoming call. In most but not all areas, the sum of RENs should not exceed five (5.0). To be certain of the number of devices that may be connected to a line, as determined by the total RENs, contact the local telephone company.

Connection to telephone company provided coin service is prohibited. Connection to party lines service is subject to state tariffs.

The installer should verify line seizure. Be aware of other phone line services such as DSL. If DSL service is present on the phone line, you must install a filter. It is suggested to use the DSL alarm filter model Z-A431PJ31X manufactured by Excelsus Technologies, or equivalent. This filter simply plugs into the RJ-31X jack and allows alarm reporting without breaking the internet connection.

3. WP8010 INSTALLATION

3. WP8010 INSTALLATION

Required tool: Philips screwdriver #2.

WP8010 mounting process is shown in Figures 3.1 - 3.9.

3.1 Opening the WP8010 Control Panel and Bracket Mounting

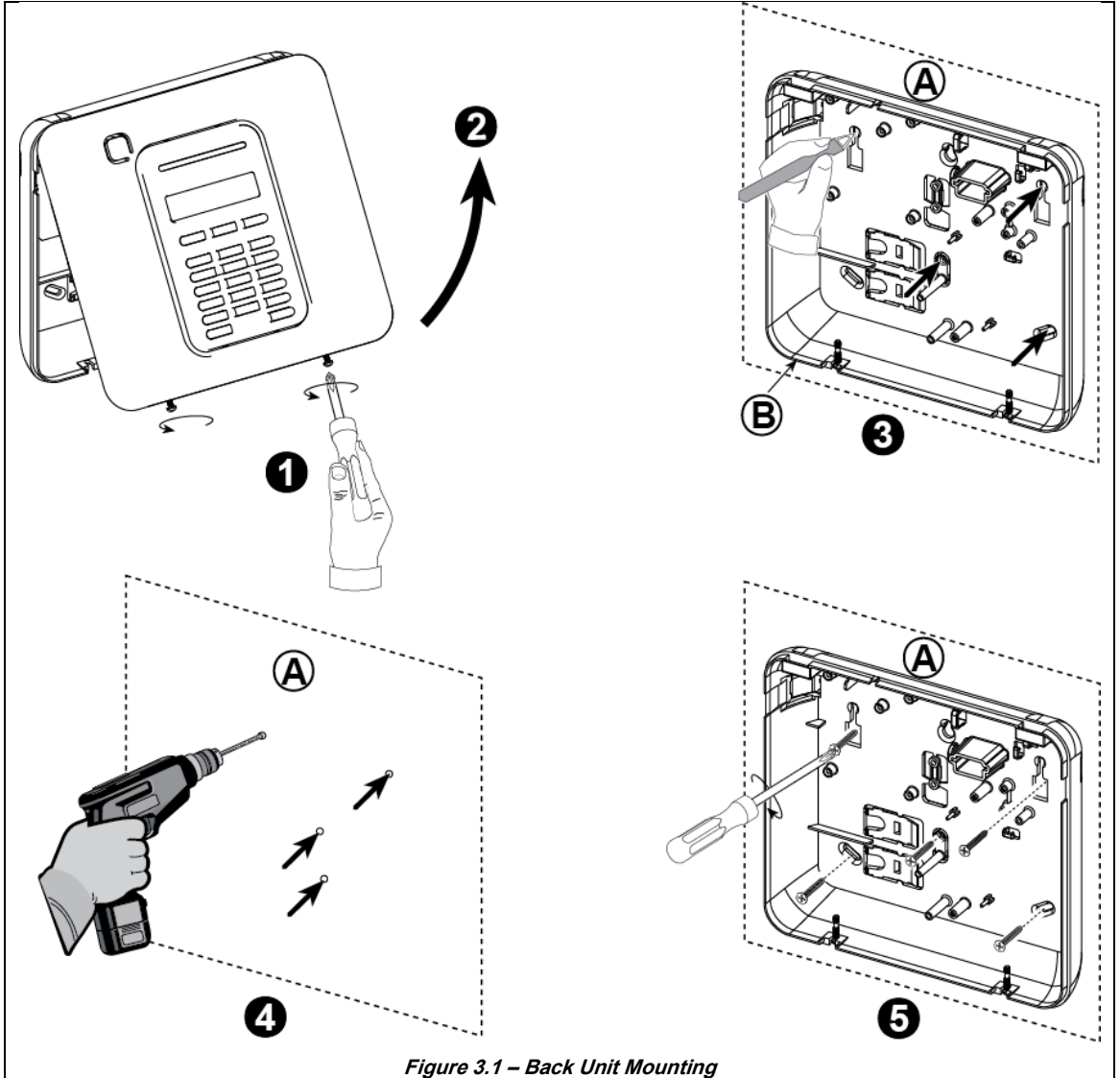

To Mount the Unit:

1. Release the screws
2. Remove the front cover
3. Mark 4 drilling points on the mounting surface
4. Drill 4 holes and insert wall anchors
5. Fasten the back unit with 4 screws

- A. Mounting surface
B. Back unit

WARNING! When plugging SIREN & ZONE terminals back into place, be sure to align them carefully with the pins on the PCB. Misaligned or reverse insertion of terminals may cause internal damage to the WP8010!

3.2 Connecting to the Telephone Line

PHONE WIRING

Connect the telephone cable to the SET connector and connect the telephone line cable to the LINE connector (through the desired wiring cable entry).

Notes:

1. The telephone cable should be no longer than 3 meters.
2. For UL installations, the telephone cable must be no less than 26 AWG.

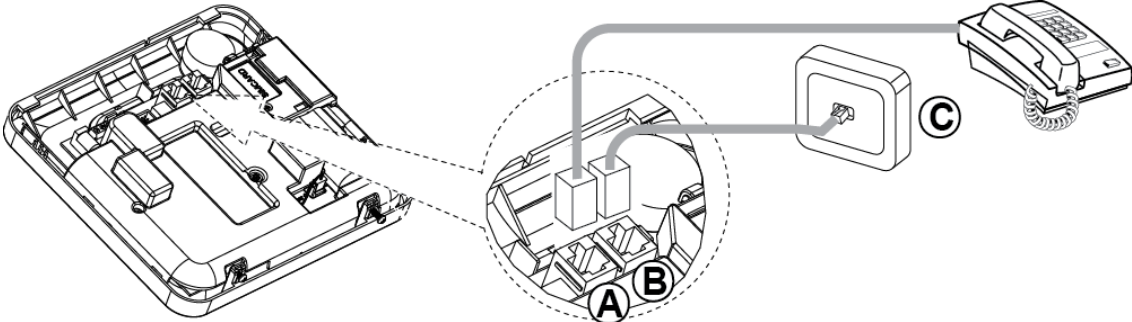

- A. SET
- B. LINE
- C. Tel line wall jack

PHONE WIRING IN NORTH AMERICA

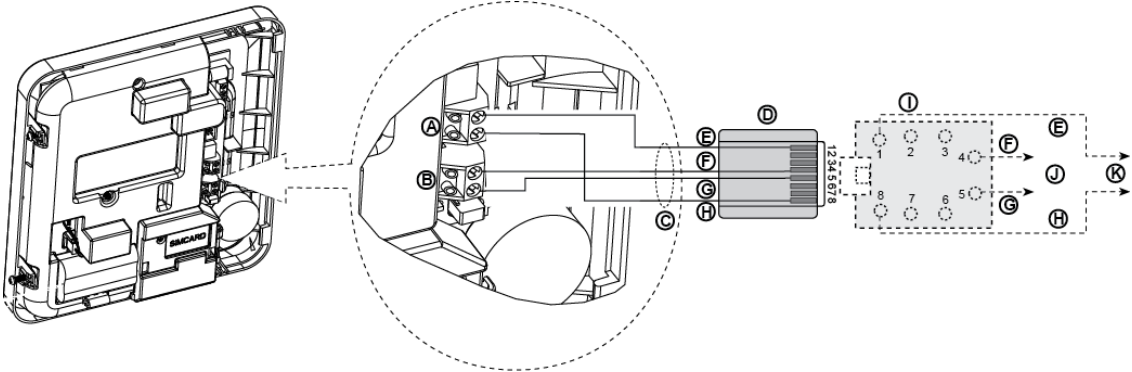

- A. SET
- B. LINE
- C. RJ-31X cord
- D. 8-position RJ-31X plug
- E. Gray
- F. Red
- G. Green
- H. Brown
- I. RJ-31X jack
- J. Line from street
- K. House phones

Figure 3.2 –Phone Wiring

This equipment is designed to be connected to the telephone network using an RJ11 connector which complies with Part 68 rules and requirements adopted by ACTA and a properly installed RJ31X connector. See drawing above for details.

In the case that RJ31X is not available (consult your telephone company or a qualified installer), the telephone line should be connected to the WP8010 unit first and then all other home equipment should be connected to the WP8010 "Phone" outlet.

3. WP8010 INSTALLATION

3.3 System Planning & Programming

Program the system now as instructed in the programming section.

The tables in APPENDIX C will help you plan and record location of each detector, the holder and assignment of each transmitter.

3.4 GSM Module Installation

The internal GSM 350 module enables the WP8010 system to operate over a GSM/GPRS cellular network (for further details, see the GSM 350 PG2 Installation Instructions).

The GSM modem auto detection feature enables automatic enrollment of the GSM modem into the WP8010 control panel memory. GSM modem auto detection is activated in one of two ways: after tamper restore and after reset (power-up or after exiting the installer menu). This causes the WP8010 to automatically scan GSM COM ports for the presence of the GSM modem.

In the event that the GSM modem auto detection fails and the modem was previously enrolled in the WP8010G2 control panel, the message "Cel Remvd Cnfrm" will be displayed. This message will disappear from the display only after the user presses the **OK** button. The modem is then considered as not enrolled and no GSM trouble message will be displayed.

Note:

A message is displayed only when the WP8010 alarm system is disarmed.

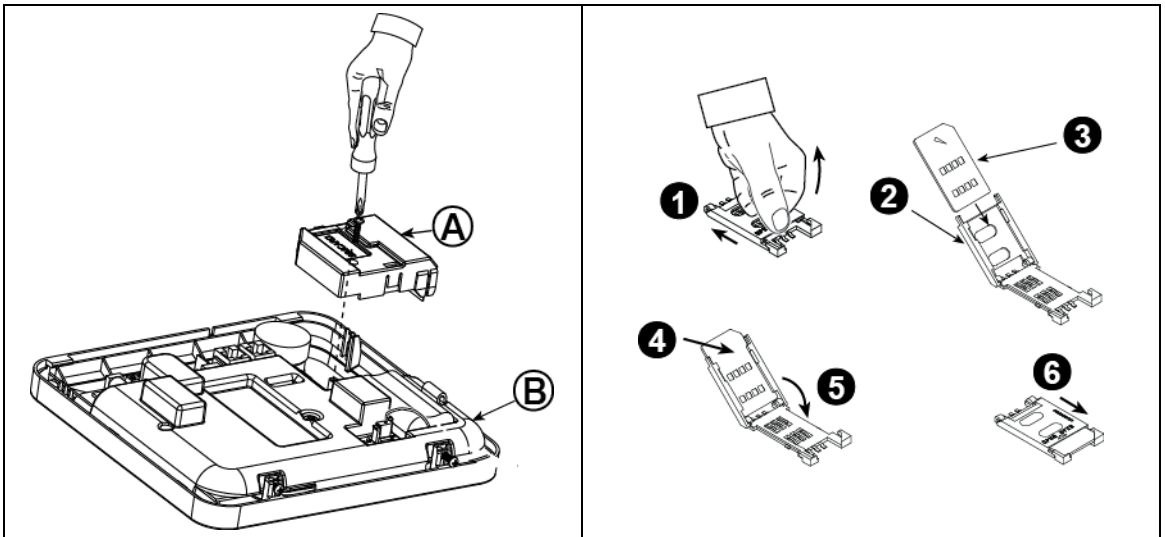

Plug in the GSM module and fasten it as shown in the above drawing.

A. GSM

B. Front unit

Caution! Disconnect both batteries and AC power before installing or removing the GSM module or SIM card.

Insert the SIM card into the GSM module as shown in the above drawing.

1. Slide top cover.

2. Open cover

3. Align SIM card in cover (note cover orientation)

4. Slide SIM card into cover

5. Rotate cover to close

6. Lock cover to close

IMPORTANT! Do not insert or remove SIM card when the control panel is powered by AC power or battery.

Figure 3.4 – Optional GSM Module Mounting and SIM Card Insertion

3.5 PGM-5 Installation

PGM-5 is an output interface module designed to provide alarm, trouble events and status signals to external devices such as long range wireless monitoring transmitters, CCTV systems, home-automation systems and LED annunciation panels (for further details see the PGM-5 Installation Instructions).

The PGM-5 provides 5 solid state relay contact outputs and is designed to be used as a plug-in internal add-on module with the WP8010 control panel.

Notes:

1. The PGM-5 will be active only if the PGM-5 option was enabled in the factory default of the control panel.
2. PGM-5 plug-in module not enabled in UL Listed product.

Caution! When mounting the PGM-5 module it is strongly recommended to route the cable as shown in Figure 3.5 to prevent interference which may occur if routed too close to the control panel antennas.

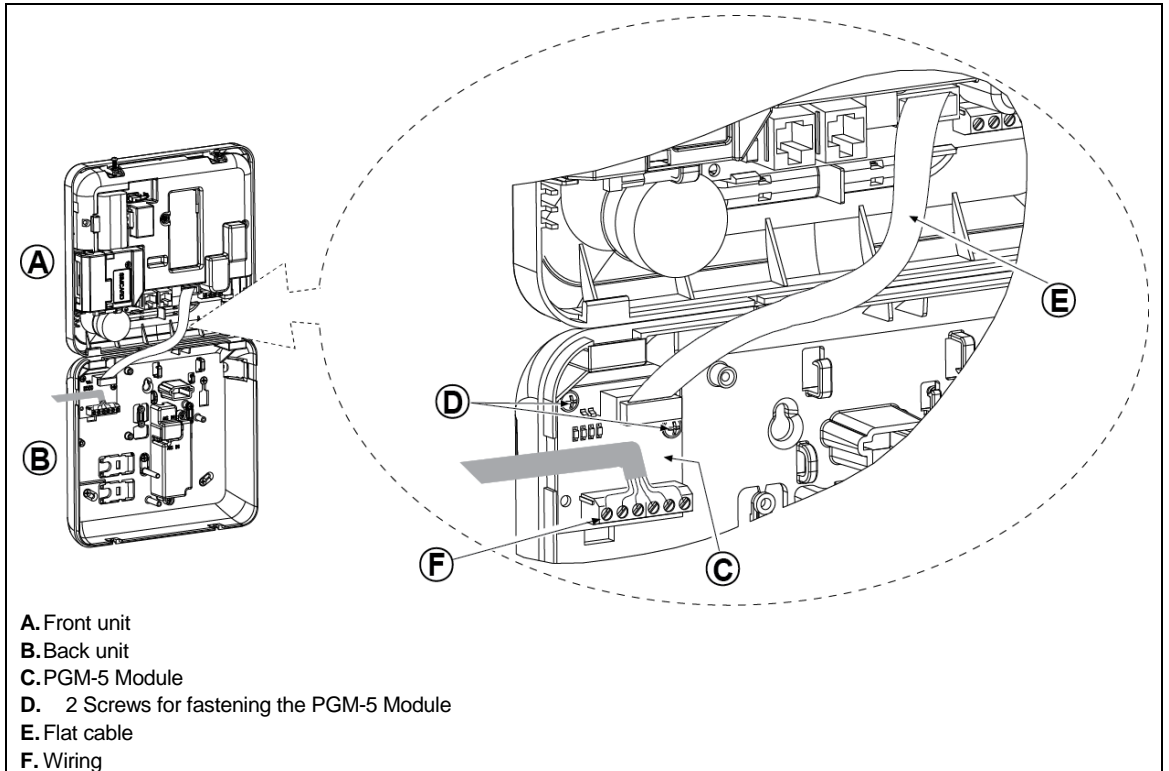

Figure 3.5 – PGM-5 Module Mounting

3. WP8010 INSTALLATION

3.6 Adding Wired Zones or PGM Device

Required tools: Cutter and slotted screwdriver - 3 mm blade.

WP8010wiring is shown in Figures 3.6a – 3.7b.

CABLES ROUTING GUIDE

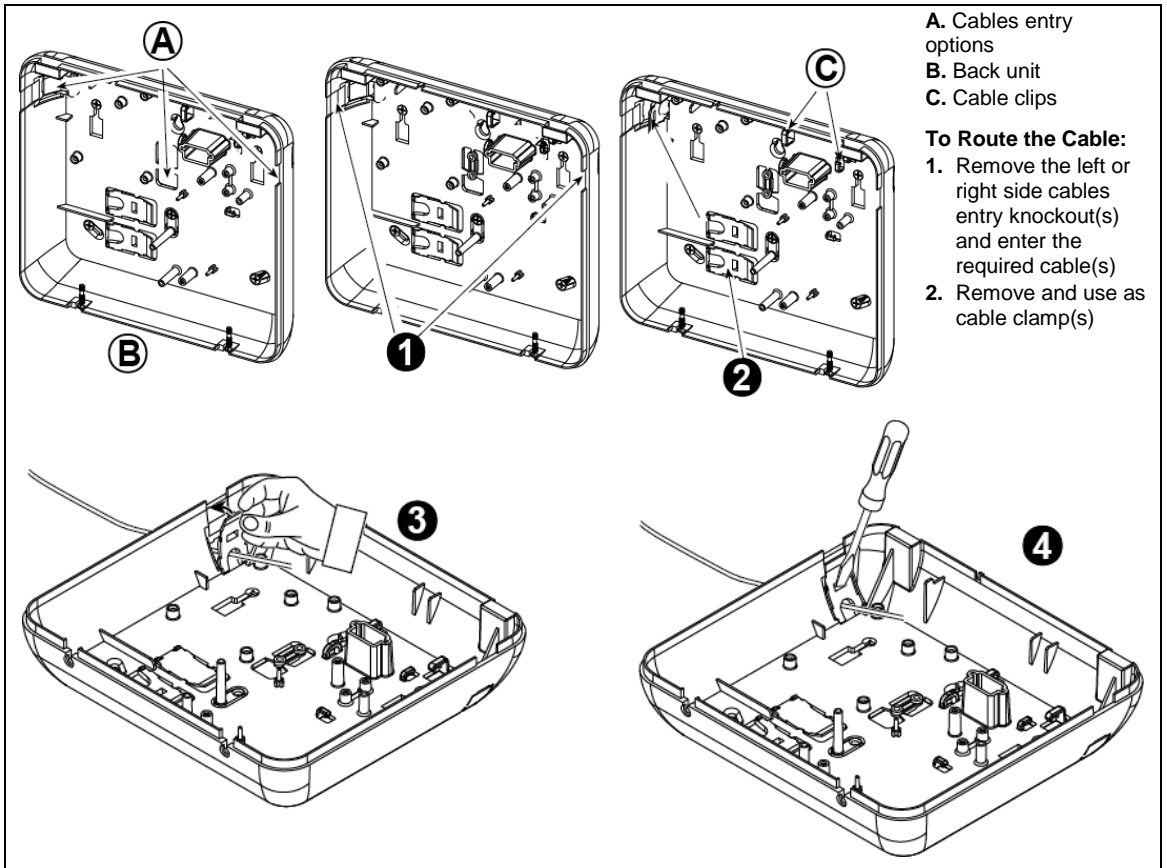

To Route the Cable (continued):

3. Position the clamp (1 of 2) as shown and then rotate into place.

4. Using a slotted screwdriver press downward gently on the point illustrated in the drawing. Make sure the clamp is locked (a click is heard).

Figure 3.6a – Cable Wiring

PGM AND ZONE WIRING

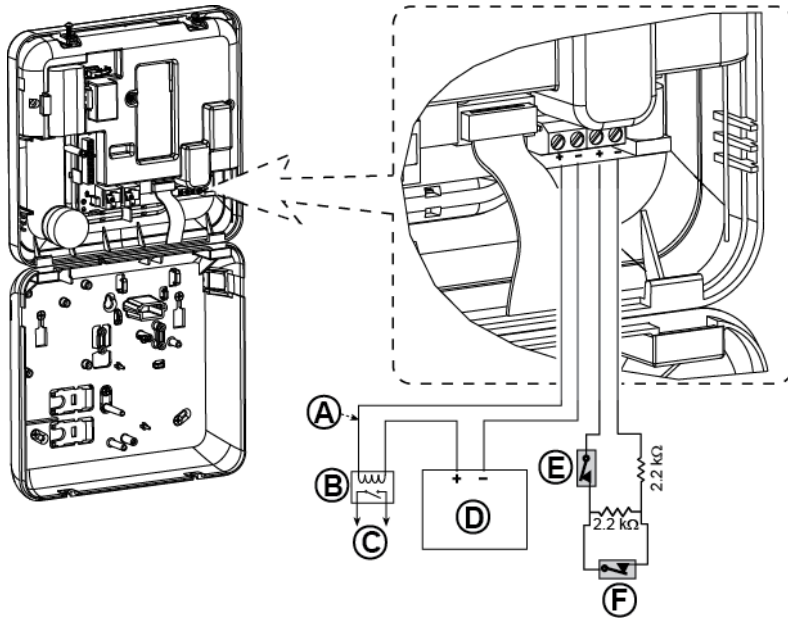

- A.** PGM output
V_{max}=30v
I_{max}=100mA
- B.** Relay
- C.** Device
- D.** External power supply 5 - 30VDC*
- E.** Wired detector's Tamper*
- F.** Wired detector's alarm or Arming Key (see section 5.4.2, "Zone Type List" table).

* For UL installations, D and E must be UL listed.
 ** PGM: not to be enabled in UL listed product.

Note:

The wired detector should be installed at least 2 meters away from the control panel.
 Regarding the wired zone, the control panel classifies the events according to the resistance it measures as shown in the table below.

E.O.L or Arming Key Resistance

Range	Zone	Arming Key
0 kΩ ↔ ~1.76 kΩ	Tamper	Tamper
~1.76 kΩ ↔ ~2.64 kΩ	Normal	Arm
~2.64 kΩ ↔ ~3.52 kΩ	Tamper	Tamper
~3.52 kΩ ↔ ~5.26 kΩ	Alarm	Disarm
~5.26 kΩ ↔ ∞	Tamper	Tamper

Notes:

1. The E.O.L resistors are 2.2 kΩ resistors of 1/4 W, 5% supplied with the panel and are UL listed under the name EOLR-3, kit number 57000850.
2. If the Arming Key is enabled, the wired zone must be located in the protected area.

Figure 3.6b – PGM & Zone Wiring

Notes for UL installations:

1. A device that is connected to PGM terminal should not be programmed to be activated during standby.
2. The system shall be installed in accordance with CSA C22.1 Canadian Electrical Code, Part 1.
3. A minimum spacing of 1/4 inch shall be maintained between the telephone wiring and the low voltage wiring (zones, bell circuit, etc.). Do not route the LINE and SET wires in the same wiring channel with other wires.
4. Do not connect to a receptacle controlled by a switch.
5. Hard wired zones are for BURGLAR use only.
6. Tamper (E) must be UL Listed.
7. Minimum System Configuration for BURGLAR consists of: Control Panel (WP8010 or WP8030). Intrusion Detection Device (Magnetic Contact, PIR, Wired Zone etc.) compatible UL Listed Monitoring Station Receiver.
8. Minimum System Configuration for FIRE consists of: Control Panel (WP8010 or WP8030). Zone etc, Smoke Detector (SMD-426/427 PG2), compatible UL Listed Monitoring Station Receiver.

3. WP8010 INSTALLATION

3.7 Connecting Power to the Control Panel

CONNECTING AC POWER TO CONTROL PANEL USING AC/AC TRANSFORMER

Connect the power cable and close the control panel as shown below.

Notes:

- 1) Do not use mains cable (3 m long) or power supply other than that supplied by the manufacturer DONGGUAN ORIENTAL HERO ELE. CO. LTD., model no. OH-41111AT-2.
- 2) For UL installations (UL), the plug-in transformer must have restraining means. For Canada (CUL), it cannot have restraining means.

Note: This equipment should be installed in accordance with Chapter 2 of the National Fire Alarm Code, ANSI/NFPA 72 and CAN/ULC-S540.

Connect the power adapter to the power connector.

Figure 3.7a - Power Cable Connection

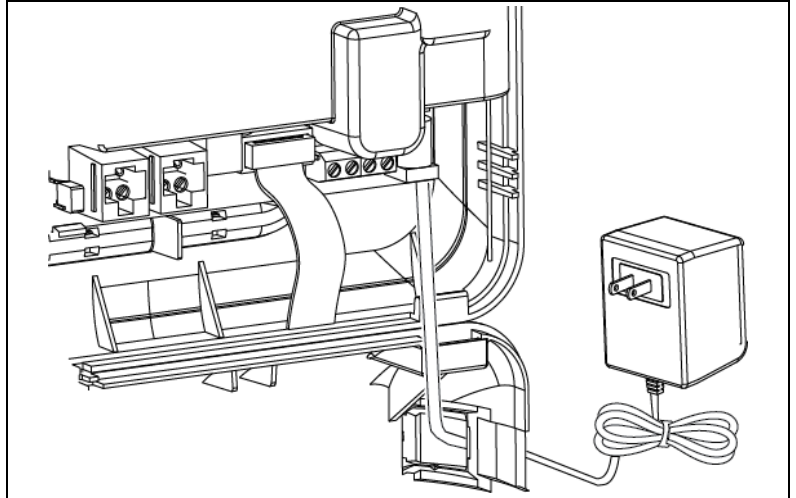

3. WP8010 INSTALLATION

CONNECTING AC POWER USING INTERNAL AC/DC POWER SUPPLY UNIT

PERFORM STEPS 1 and 2 ON A WORKBENCH BEFORE THE MOUNTING

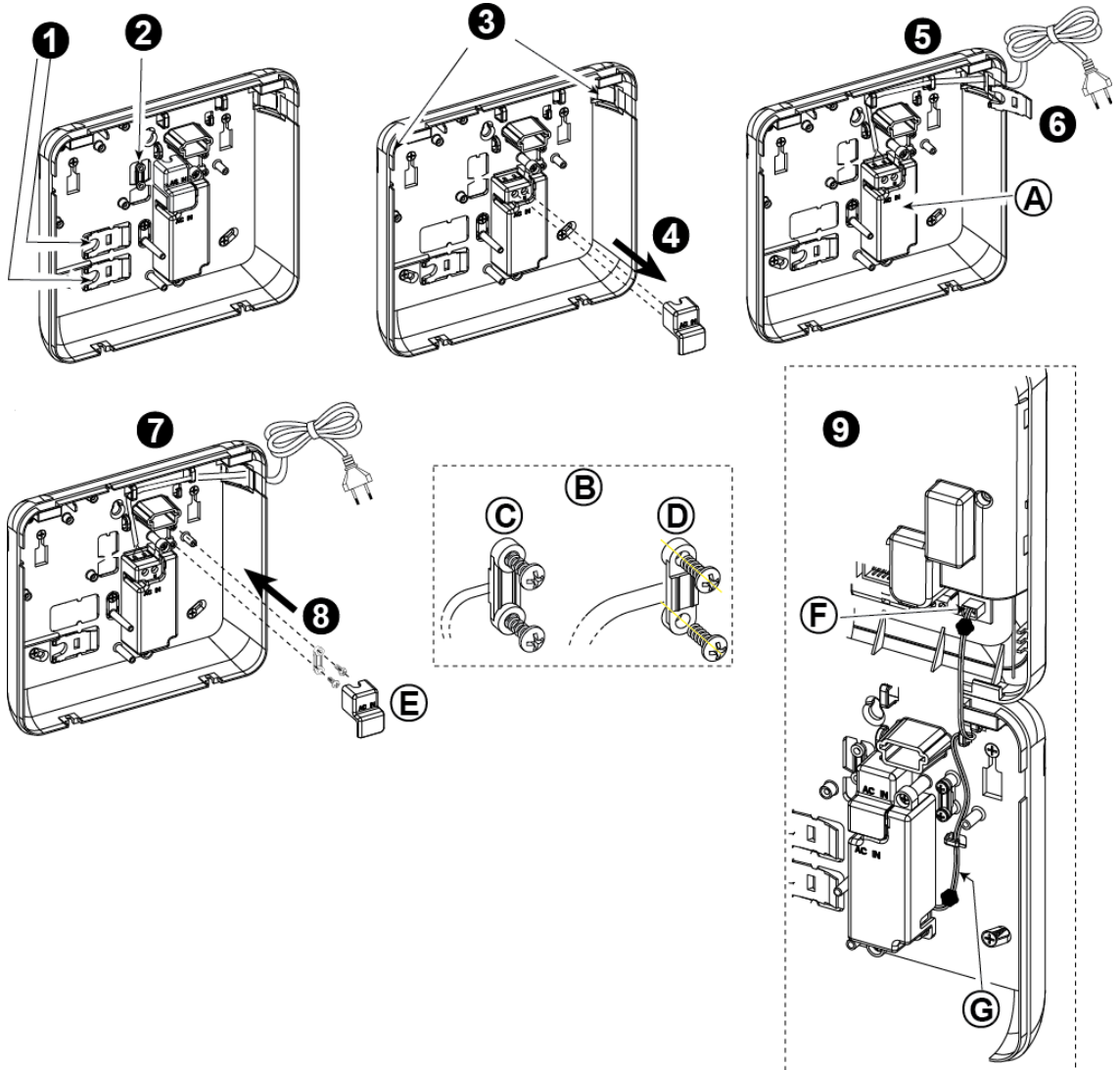

1. Extract either plastic segment (will be used later)
 2. Extract plastic segment (will be used later)
 3. Knock out the plastic segment (left or right, according to the power wiring direction)
 4. Remove power supply terminals cover (E)
 5. Insert the power cable through the desired wiring channel, route it to the power supply unit and connect its 2 wires to the power supply terminal block with a screwdriver. Fasten the screws tightly. Verify that the wires are properly fastened!
 6. Insert plastic cap to the power cable entry (extracted in step 1)
 7. Fasten power cable by clamp (extracted in step 2)
 8. Close power supply terminals cover
 9. Connect the DC output cable plug into the DC input socket located on the front panel.
- A. Internal AC/DC power supply unit
 B. Power cable clamp options
 C. For thin cable
 D. For thick cable (reversed clamp)
 E. Terminals cover
 F. DC input socket on front panel
 G. DC output cable

Figure 3.7b – Power Cable Wiring

3. WP8010 INSTALLATION

3.8 Supplying Power to the Unit

Connect power to the WP8010 temporarily (see Figure 3.7a). Alternatively, you may power up from the backup battery, as shown in Figure 3.8.

Disregard any "trouble" indications pertaining to lack of battery or lack of telephone line connection.

For Europe Safety Compliance:

- The model shall be installed according to the local electrical code.
- The circuit breaker shall be readily accessible.
- The rating of the external circuit breaker shall be 16A or less.
- The cables for the AC mains connection shall have an overall diameter of 13mm and 16mm conduit.

Please refer to Figure 3.7a "Power Cable Connection".

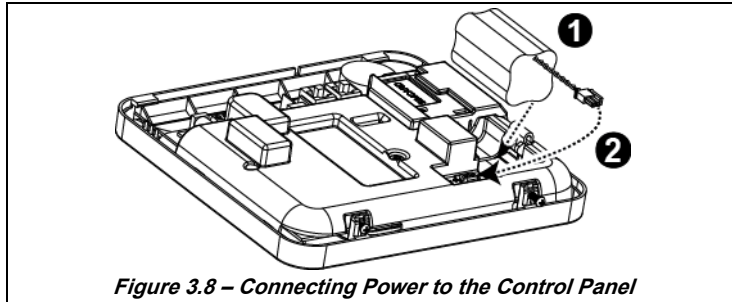

Inserting Backup Battery:

Connect battery pack as shown in Figure 3.8.

1. Insert battery
2. Connect the battery

3.9 Closing the WP8010 Control Panel

Control panel final closure is shown below.

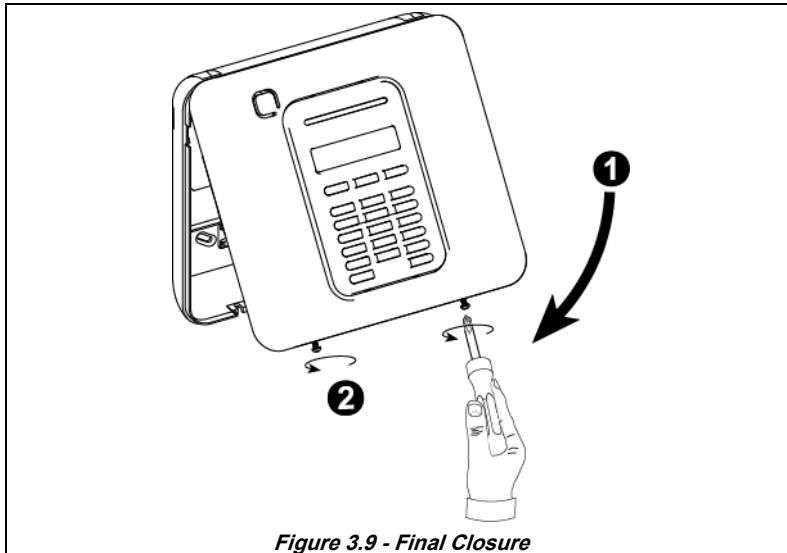

To Close the Control Panel:

1. Close the front cover
2. Fasten the screws

4. WP8030INSTALLATION

Required tool: Philips screwdriver #2.

WP8030 mounting process is shown in Figures 4.1 - 4.13.

4.1 WP8030Wiring Diagram

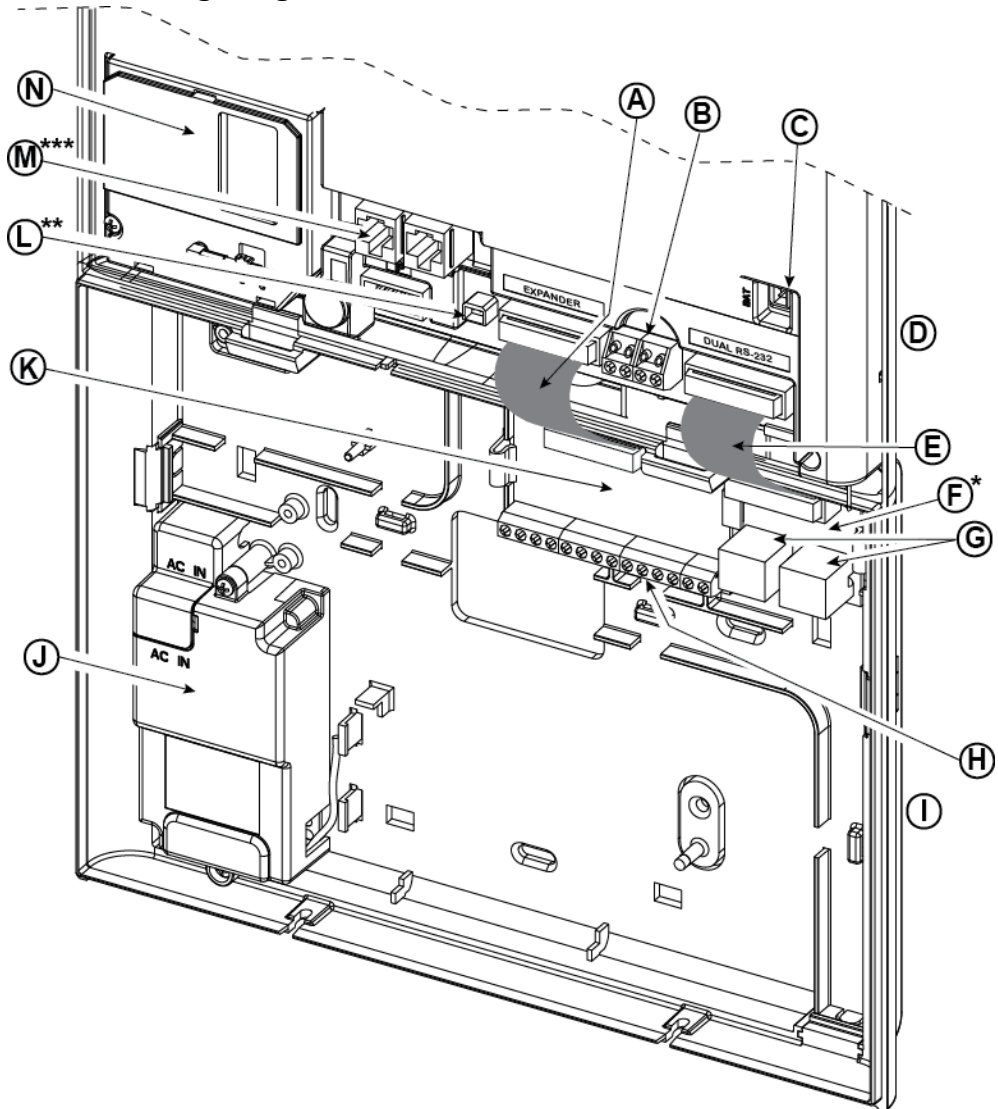

- | | | | |
|---|---|---|--|
| A. Expander Module Flat Cable | B. Wired Zone / Special Siren Terminal Block | C. Battery Connector | D. Front Unit |
| E. Dual RS-232 Module Flat Cable | F. Dual RS-232 Module Connectors | G. Dual RS-232 Module Connectors | H. Expander Module Wiring Terminal Blocks |
| I. Back Unit | J. Power Supply | K. Expander Module | L. Power Connector |
| M. Phone Wiring Connectors | N. GSM-350 PG2 | | |

* or PGM-5 Module

** or External Power Connector

*** or Terminal Block in North American Panels

Figure 4.1 – WP8030Wiring Diagram

3. WP8010 INSTALLATION

4.2 Opening the WP8030 Control Panel and Bracket Mounting

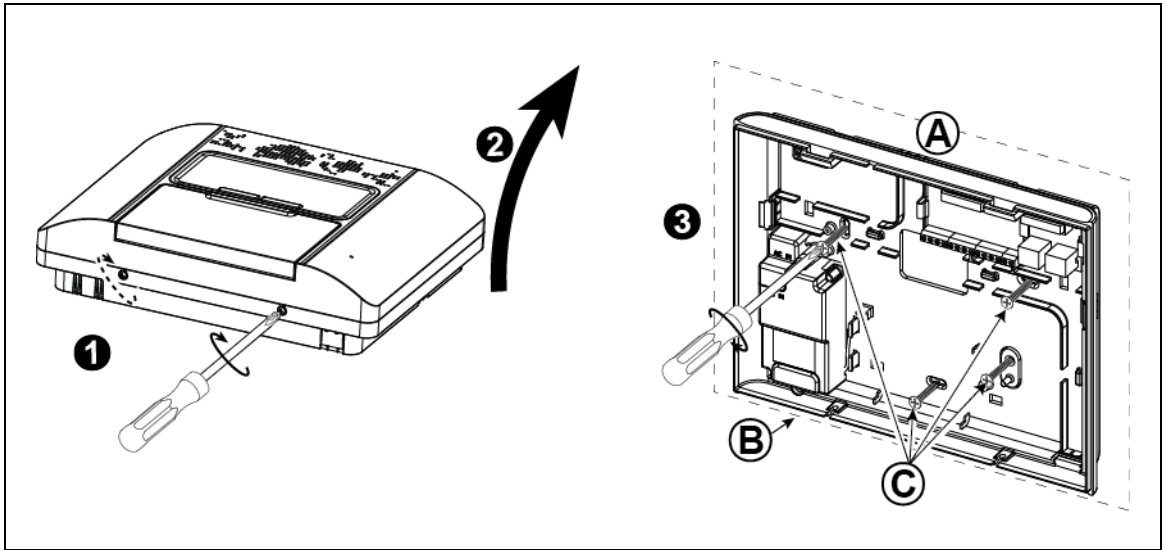

To Mount the Unit:

1. Release the screws
2. Remove the front cover
3. Mark 4 drilling points on the mounting surface, then drill 4 holes and insert wall anchors and then fasten the back unit with 4 screws

A. Mounting surface

B. Back unit

C. Screws

Figure 4.2 – Back Unit Mounting

4.3 Connecting to the Telephone Line

(detail "M" in Figure 4.1)

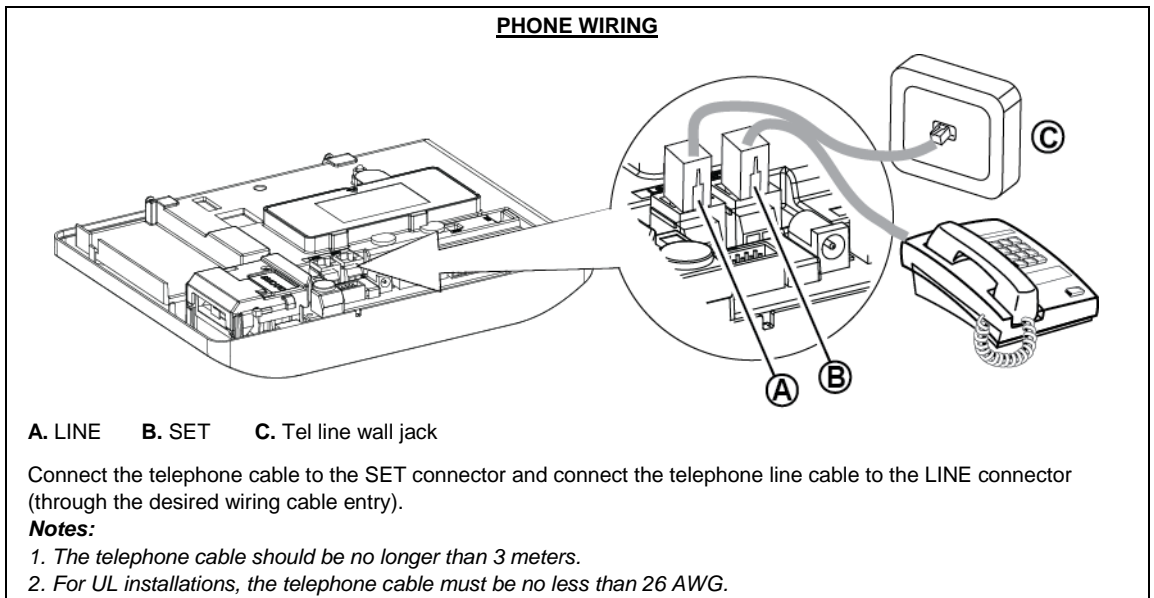

Figure 4.3a – Phone Wiring

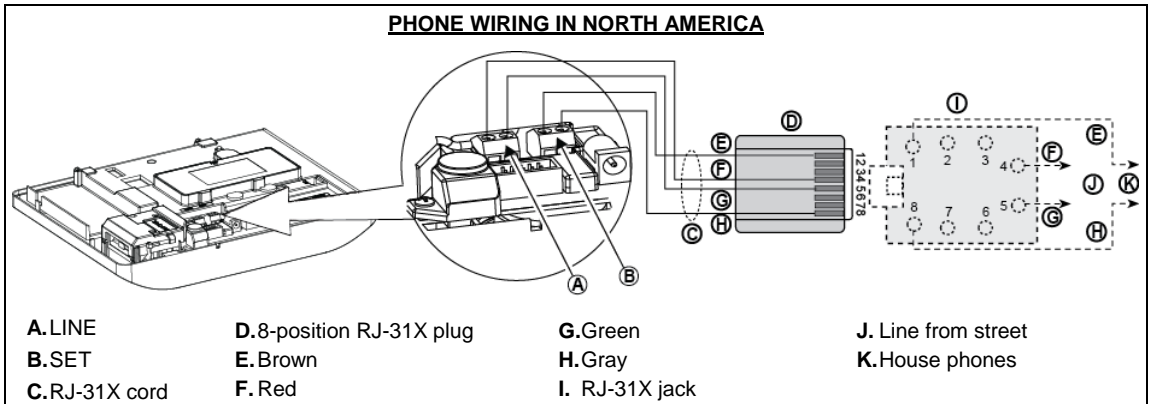

Figure 4.3b – Phone Wiring in North America

Phone wiring in the UK: Line terminals must be connected to pins 2 and 5 of the wall jack.

For all installations: If DSL service is present on the phone line, you must route the phone line through a DSL filter (refer to MESSAGE TO THE INSTALLER on page 2 for further details).

4.4 Connecting Wired Zone and Siren

(detail "B" in Figure 4.1)

If an expander module is not used, one wired zone and one low voltage siren can be connected directly to the front panel PCB (not allowed in UL installations).

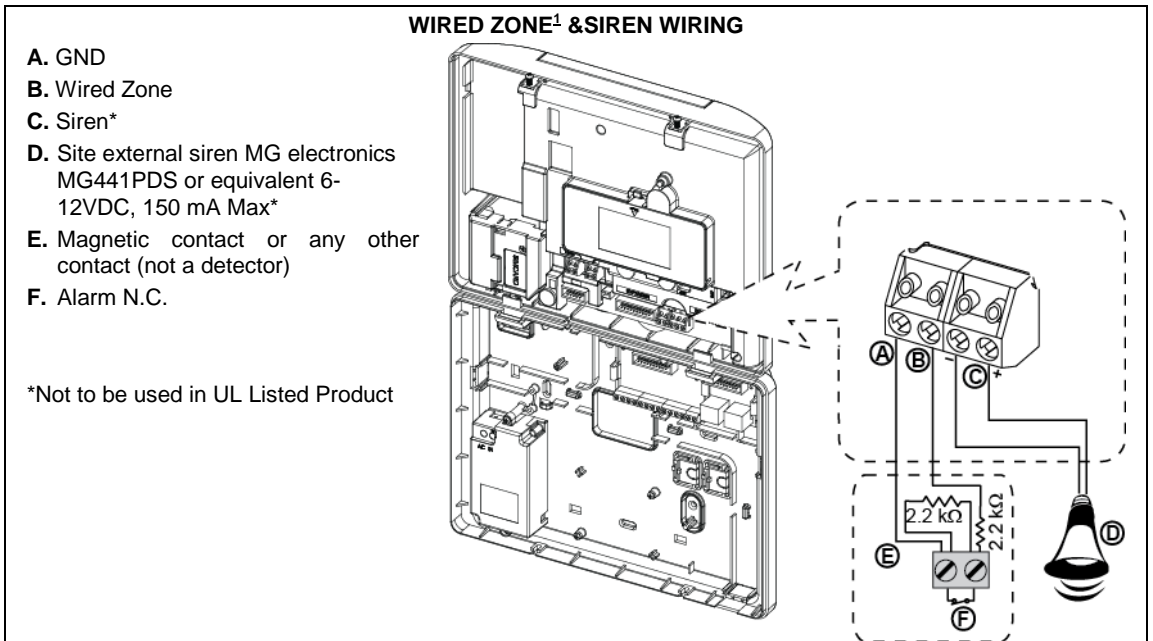

Figure 4.4 – Wired Zone and Siren Wiring

4.5 System Planning & Programming

Program the system now as instructed in the programming section.

The tables in APPENDIX C will help you plan and record the location of each detector, the holder and assignment of each transmitter.

¹ Wired zones can be enrolled in any zone in the WP8030 control panel from 01 to 64

4.6 GSM Module Installation

(detail "N" in Figure 4.1)

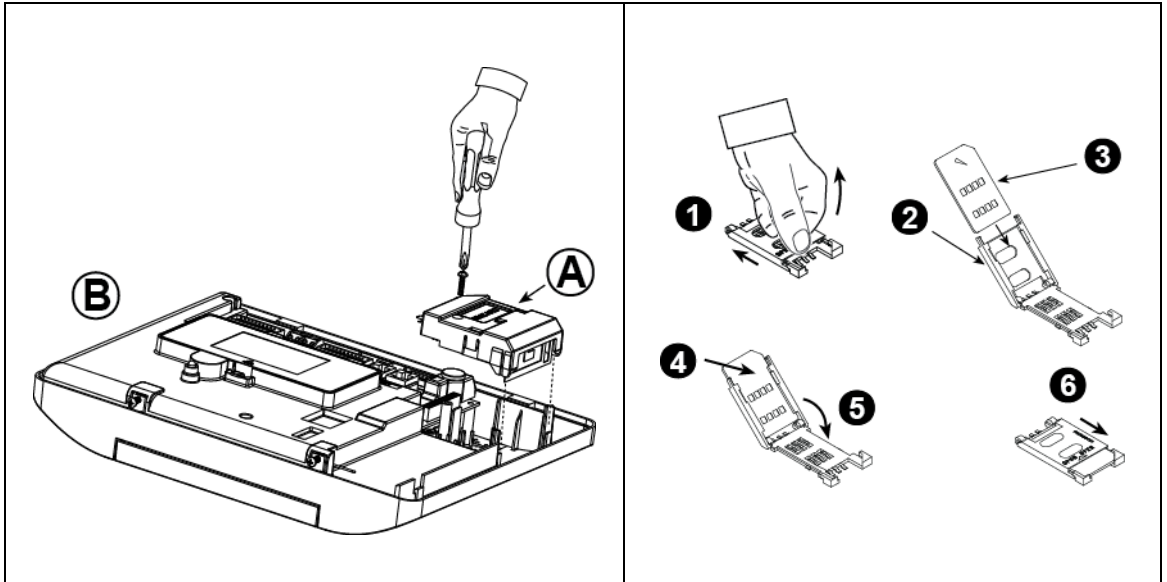

Plug in the GSM module and fasten it as shown in the above drawing.

A. GSM

B. Front unit

Caution! Do not install or remove the GSM module when the system is powered by AC power or backup battery.

Insert the SIM card into the GSM module as shown in the above drawing.

1. Slide top cover.
2. Open cover
3. Align SIM card in cover (note cover orientation)
4. Slide SIM card into cover
5. Rotate cover to close
6. Lock cover to close

IMPORTANT! Do not insert or remove SIM card when the control panel is powered by AC power or battery.

Figure 4.6– Optional GSM Module Mounting and SIM Card Insertion

4.7 DUAL RS-232 Optional Module Mounting

(detail "F" in Figure 4.1)

The Dual RS-232 is a module that enables connection of any two simultaneous devices, such as Local PC programming or GSM Module.

The GSM unit enables the WP8030system to operate over a cellular network (for details regarding the GSM modem features and connections, refer to the GSM Modem installation instructions).

Note: The Dual RS-232 Module is not to be connected in UL Listed product.

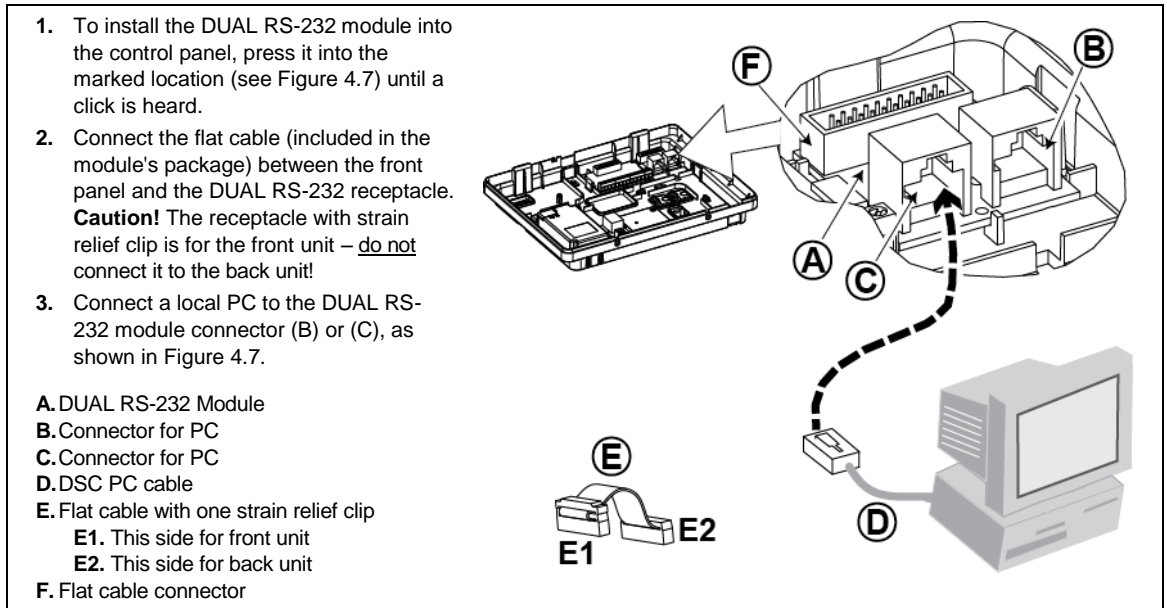

Figure 4.7 –Dual RS-232 Module Mounting

4.8 PGM-5 Installation

(located instead of detail "F" in Figure 4.1)

PGM-5 is an output interface module designed to provide alarm, trouble events and status signals to external devices such as long range wireless monitoring transmitters, CCTV systems, home-automation systems and LED annunciation panels (for further details see the PGM-5 Installation Instructions).

The PGM-5 provides 5 solid state relay contact outputs and is designed to be used as a plug-in internal add-on module with the WP8030control panel.

Mount the PGM-5 module as shown in Figure 4.8.

1. Press downward on the PGM-5 module (D), located in the back panel, between its 2 clips.
2. Connect the PGM-5 module flat cable (F) to the front panel PGM-5 receptacle and to the flat cable receptacle of the PGM-5 (G).

Caution! The connector with strain relief clip (F1) is for the front unit – do not connect it to the back unit!

Notes:

- i) The PGM-5 will be active only if the PGM-5 option was enabled in the factory default of the control panel.
- ii) For wiring instructions, refer to the PGM-5 Installation Instructions included in the module's package.
- iii) PGM-5 plug-in module not evaluated by UL.

Caution! When mounting the PGM-5 module it is strongly recommended to route the wiring cable (E) as shown in Figure 4.8) to prevent interference which may occur if routed too close to the control panel antennas.

3. WP8010 INSTALLATION

- A. WP8030connector
- B. Front unit
- C. PGM-5 Module
- D. Back unit
- E. Wiring Cable
- F. Flat cable
 - F1. This side for front unit
 - F2. This side for back unit
- G.PGM-5 flat cable receptacle

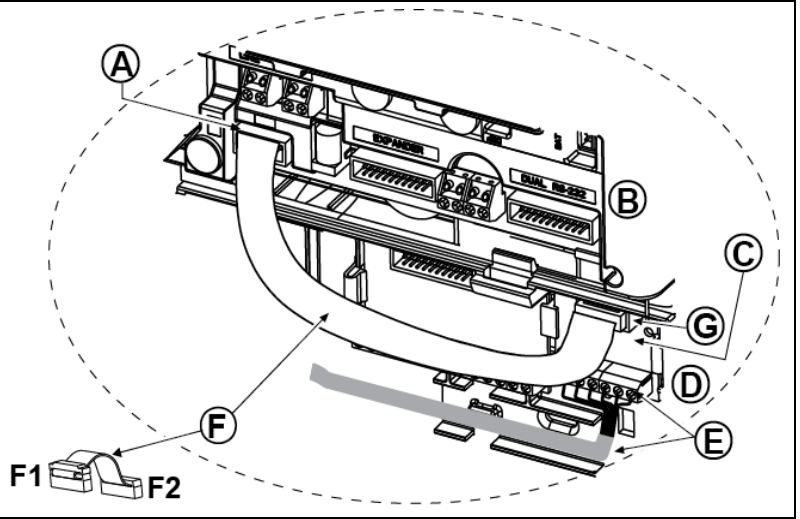

Figure 4.8 – PGM-5 Module Mounting

4.9 Optional Expander Module

(detail "K" in Figure 4.1)

The Expander module is an optional module. If this optional module is used, the wired zone or special siren on the front panel should not be used.

Note: The optional Expander Module not to be connected in UL Listed product.

Mount the Expander module as shown in Figure 4.9a.

1. Press downward on the Expander module (located in the back panel) between its 2 clips.
2. Connect the Expander module flat cable to the front panel Expander receptacle.

Caution! The receptacle with strain relief clip is for the front unit – do not connect it to the back unit!

- A. 2 clips
- B. Flat cable with one strain relief clip
- B1. This side for front unit
- B2. This side for back unit

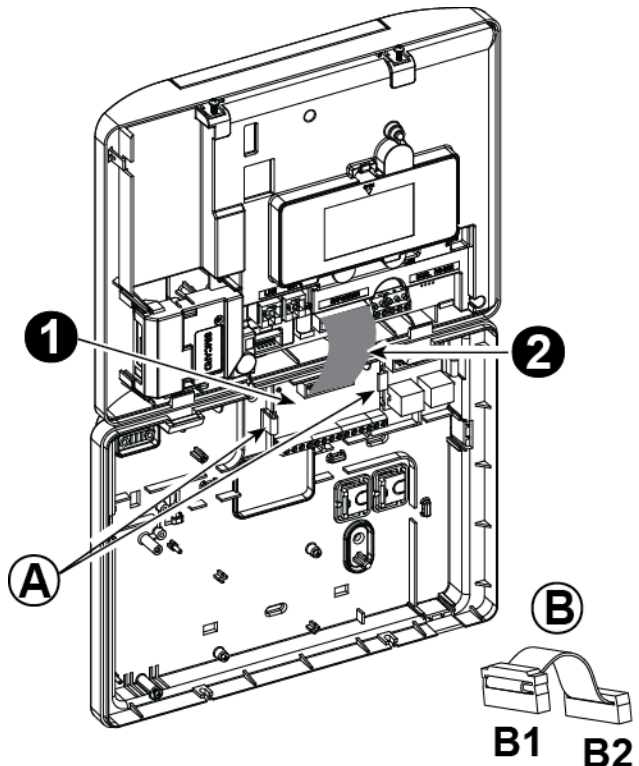
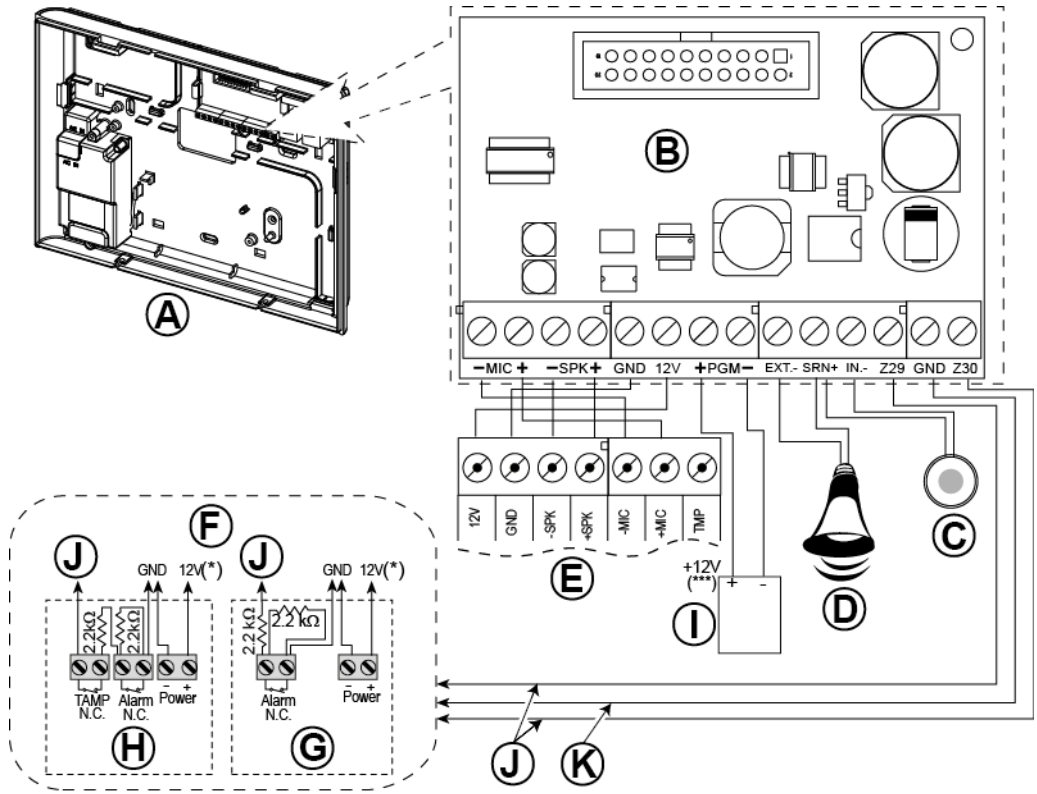

Figure 4.9a –Expander Module

OPTIONAL EXPANDER MODULE, ZONES, SIRENS, AUDIO BOX AND WIRED DETECTORS WIRING



- A. Back Unit
- B. Expander
- C. Internal siren or strobe 6-12 VDC, 150 mA Max.
- D. External siren MG441PDS or similar siren 12 VDC (nominal) 350 mA Max.
- E. Voice box
- F. Connect wired detectors as illustrated.

Note:
 The wired detector should be installed at least 2 meters away from the control panel.
 Regarding the two wired zones, the control panel classifies the events according to the resistance it measures as shown in the table below.

E.O.L or Arming Key Resistance

Range	Zone	Arming Key
0 kΩ ↔ ~1.76 kΩ	Tamper	Tamper
~1.76 kΩ ↔ ~2.64 kΩ	Normal	Arm
~2.64 kΩ ↔ ~3.52 kΩ	Tamper	Tamper
~3.52 kΩ ↔ ~5.26 kΩ	Alarm	Disarm
~5.26 kΩ ↔ ∞	Tamper	Tamper

- Notes:**
1. The E.O.L resistors are 2.2 kΩ resistors of 1/4 W, 5% supplied with the panel and are UL listed under the name EOLR-3, kit number 57000850.
 2. If the Arming enabled is set, the wired zone must be located in the protected area.
- G. Detector without tamper switch or Arming Key (see section 5.4.2, "Zone Type List" table).
 - H. Detector with tamper switch or arming key's tamper
 - I. PGM device
 - J. Wired zone A or B
 - K. Ground (GND)

Figure 4.9b – Zone and Siren Wiring*

3. WP8010 INSTALLATION

Notes for EXPANDER module wiring:

- * *Wired zone* terminals can be connected to a normally closed contact of a detector, switch (for example a Tamper switch of any device), or a pushbutton, via a 2.2 K Ω resistor. **The 12V terminal can be used to supply 12V** (up to 36mA) to a detector (if necessary).
- ** The EXT terminal can be used to trigger an external siren.
The INT terminal can be programmed for an "internal siren" or "strobe" (see par. 5.7).
The 12V and "GND" terminals can be connected to a siren (for constant DC power supply).
- *** The 12V supply to the PGM device is fused. Current is limited to 100 mA.

WARNING! When plugging terminals back into place, be sure to align them carefully with the pins on the PCB. Misaligned or reverse insertion of terminals may damage internal WP8030circuits!

IMPORTANT! The terminals for internal and external sirens are DC outputs intended for 12V sirens. Connecting a loudspeaker to any of these outputs will cause a short circuit and will damage the unit.

Notes for UL installations:

1. A device that is connected to PGM terminal should not be programmed to be activated during standby.
2. The system shall be installed in accordance with CSAC22.1 Canadian Electrical Code, Part 1.
3. A minimum spacing of 1/4 inch shall be maintained between the telephone wiring and the low voltage wiring (zones, bell circuit, etc.) Do not route the LINE and SET wires in the same wiring channel with other wires.
4. Do not connect to a receptacle controlled by a switch.
5. Hard wired zones are for BURG use only.
6. Alarm Contact (F) and/or Magnetic Contact must be UL Listed.
7. Minimum System Configuration for BURG consists of: Control Panel (WP8010 or WP8030). Intrusion Detection Device (Magnetic Contact, PIR, Wired Zone etc) compatible UL Listed Monitoring Station Receiver.
8. Minimum System Configuration for FIRE consists of: Control Panel (WP8010 or WP8030). Zone etc., Smoke Detector (SMD-426/427 PG2), compatible UL Listed Monitoring Station Receiver.

4.10 Connecting Power to the Control Panel

Notes:

1. Do not use mains cable (3 m long) or power supply other than that supplied by the manufacturer LEADER ELECTRONICS, model no. MU24-11125-A10F. For UL installations, model no. MU15-R125120-A1, p/n MU15-R1125-A00S. For ULC installations, model no. MU15- R125120-A1, p/n MU15-R1125-A01S.
2. For UL installations (UL), the plug-in transformer must have restraining means. For Canada (CUL), it cannot have restraining means.
3. This equipment should be installed in accordance with Chapter 2 of the National Fire Alarm Code, ANSI/NFPA 72 and CAN/ULC-S540.

Connect the power cable and close the control panel as shown in Figures 4.10a – 4.10b.

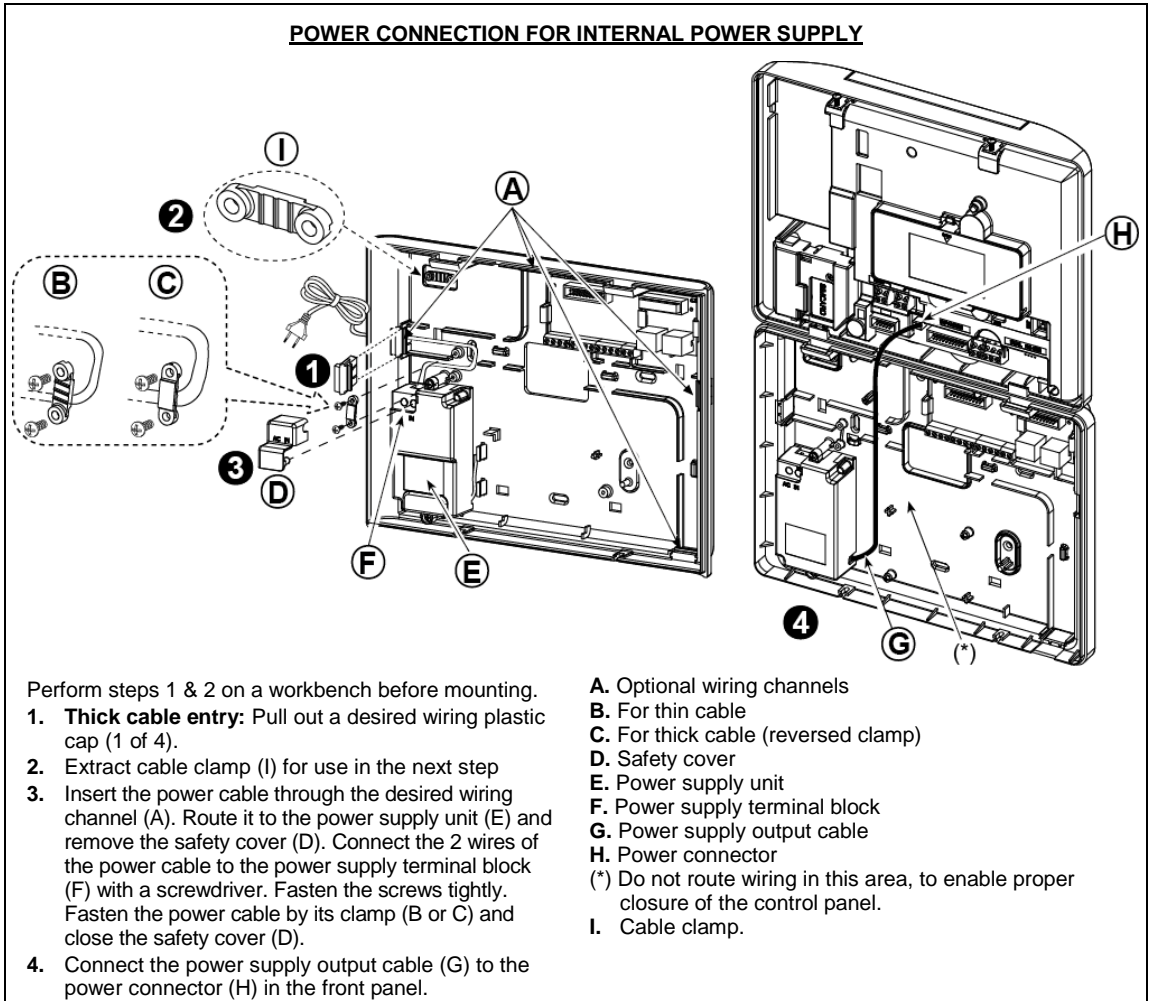
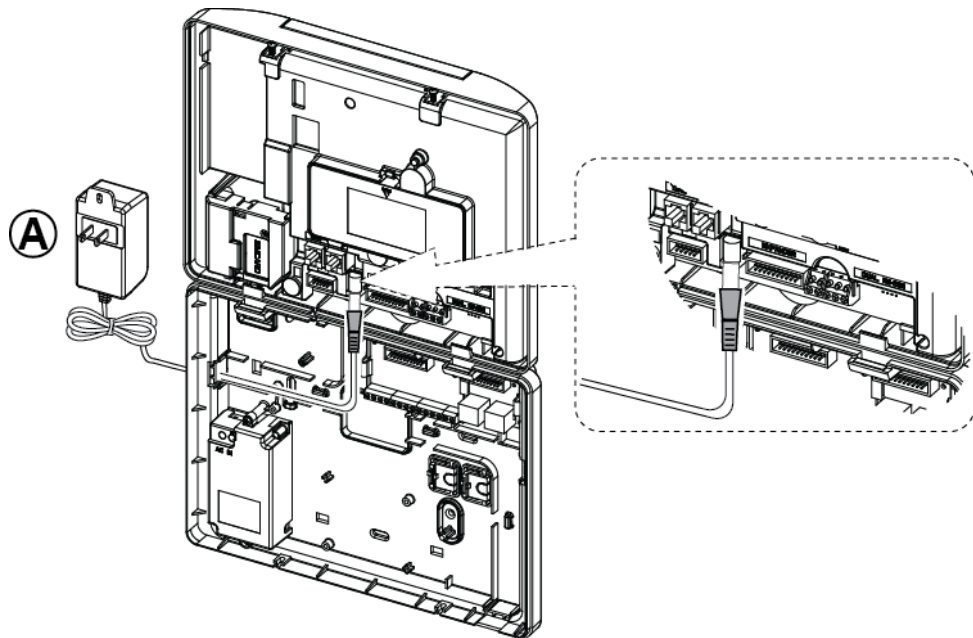

Figure 4.10a – Power Connection For Internal Power Supply

3. WP8010 INSTALLATION

EXTERNAL POWER CONNECTION



Connect the power adaptor to the front panel power connector.

A. Power supply manufacturer LEADER ELECTRONICS. For UL installations, model no. MU15-R125120-A1, p/n MU15-R1125-A00S. For ULC installations, model no. MU15- R125120-A1, p/n MU15-R1125-A01S.

Figure 4.10b – External Power Connection

4.11 Battery Insertion

Open battery compartment cover. Insert one 6-battery pack or 8-battery pack and connect its connector as shown in Figure 4.11.

A. Front unit

B. Battery cable

C. Battery cable connector

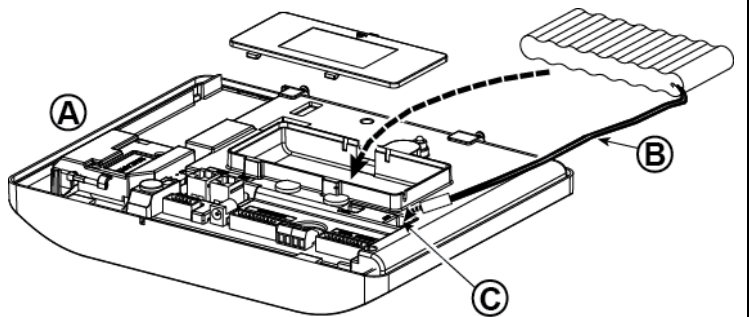

Figure 4.11 – Battery Insertion

4.12 Supplying Power to the Unit

Connect power to the WP8030 temporarily (see Figures 4.10a and 4.10b). Alternatively, you may power up from the backup battery, as shown in Figure 4.11.

Disregard any "trouble" indications pertaining to lack of battery or lack of telephone line connection.

For Europe Safety Compliance:

- The model shall be installed according to the local electrical code.
- The circuit breaker shall be readily accessible.
- The rating of the external circuit breaker shall be 16A or less.

Please refer to Figure 4.11 "Battery Insertion".

4.13 Closing the WP8030 Control Panel

Control panel final closure is shown below.

To Close the Control Panel:

1. Connect the flat cables, between front and back units, in their respective connectors (up to 3, according to options).
2. Close the panel and fasten the 2 screws.
3. Switch on the control panel; make sure that the "Power" indicator on the control panel lights green.

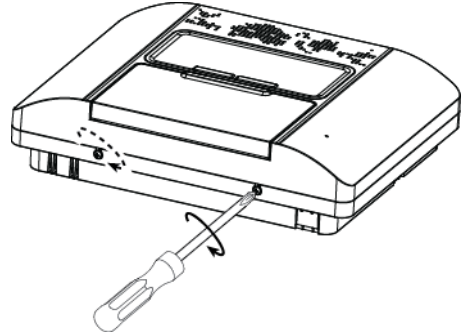

Figure 4.13 - Final Closure

5. PROGRAMMING

5.1 General Guidance

This chapter explains the Installer programming (configuration) options of your WP8010/WP8030 system and how to customize its operation to your particular needs and end user requirements.

The control panel includes a partition feature. Partitioning allows you to have up to three independently controllable areas with different user codes assigned to each partition. A partition can be armed or disarmed regardless of the status of the other partitions within the system.

The Soak Test¹ feature allows selected zones to be tested for a pre-defined period of time. When in Soak Test mode, activating a zone does not cause an alarm and siren and strobe are not activated. The zone activation is recorded in the event log and is not reported to the Monitoring Station. The zone remains in Soak Test until the pre-defined period of time for the Soak Test has elapsed without any alarm activation. The zone then automatically removes itself from Soak Test mode and returns to normal operating mode.

Software Upgrade² allows you to upgrade the software of the control panel from the remote PowerManage server. During software upgrade, the WP8010/WP8030 display will read "UPGRADING..." which is displayed throughout the software upgrade procedure.

Note: Software Upgrade cannot be performed when the control panel is armed AWAY or there is an AC failure.

Tech Tip :

For your convenience, we recommend programming the WP8010/WP8030 on the work bench before actual installation. Operating power may be obtained from the backup battery or from the AC power supply.







ATTENTION! FIRST SWITCH ON THE CONTROL PANEL and then INSERT BATTERIES INTO ACCESSORIES DEVICES.









The devices "search" for the control panels to which they are enrolled for a period of only 24 hours from the time of battery insertion.





Note: If you have switched on the control panel a long time after inserting batteries into the accessories devices: Open and then close the cover to activate the tamper switch (where applicable), or remove the battery and then put back the battery.

5.1.1 Navigation

The keypad's buttons are used for navigation and configuration when programming. The following table provides a detailed description of the function or use of each button.

Button	Definition	Navigation / Setting Function
	NEXT	Use to move / scroll forward to the next menu options.
	BACK	Use to move / scroll backward to the previous menu options.
	OK	Use to select a menu option or to confirm a setting or action .
	HOME	Use to move one level up in the menu or to return to previous setting step .
	AWAY	Use to jump back to the [<OK> TO EXIT] screen to quit programming.
	OFF	Use to cancel, delete, clear or erase setting, data, etc.
0 – 9		Numerical keypad used to enter numerical data when needed.

To review the options within the control panel menus and select an option, repeatedly press the Next  or Back  button until the desired option is displayed (also designated as   in this guide), then press the OK  button to select the desired option (also designated as  in this guide). To return to the previous options repeatedly press the Home  button and to exit the programming menu press the Away  button.





To simplify the procedure further, you really need two basic buttons to program the entire panel: The Next  and the OK  button. The  button scrolls through the options, and the  button selects the option you want.



¹ Soak Test is not applicable for UL installations.

² Software Upgrade is not applicable for UL installations

5.1.2 Feedback Sounds

The sounds you will hear while using and configuring the control panel are:

Sound	Definition
	Single beep, heard whenever a key is pressed
	Double beep, indicates automatic return to the normal operating mode (by timeout).
	Three beeps, indicates a trouble event
	Happy Tune (- - - —), indicates successful completion of an operation.
	Sad Tune (—), indicates a wrong move or rejection

You can control the volume level of the sounded beeps by pressing the  button on the keypad to increase the volume of the beeps heard, or by pressing the  button to decrease the volume of the beeps heard.

5.2 Entering the "Installer Mode" and Selecting a Menu Option

All installer menu options are accessed via the "Installer Mode" which is usually one of the main panel menu options.

To enter the "Installer Mode" and select an Installer Menu Option proceed as follows:

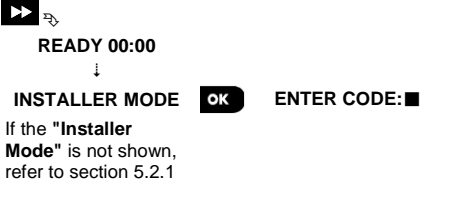
Step 1	Step 2	Step 3	Step 4																																
Select "INSTALLER MODE" Option [1]	Enter Installer Code [2]	Select "Installer Menu" Option [3]																																	
 <p>If the "Installer Mode" is not shown, refer to section 5.2.1</p>		<table border="1"> <thead> <tr> <th></th> <th>See</th> <th></th> <th>See</th> </tr> </thead> <tbody> <tr> <td>01:INSTALL CODES</td> <td>5.3</td> <td>08:USER SETTINGS</td> <td>5.10</td> </tr> <tr> <td>02:ZONES/DEVICES</td> <td>5.4</td> <td>09:FACTORY DEFLT</td> <td>5.11</td> </tr> <tr> <td>03:CONTROL PANEL</td> <td>5.5</td> <td>10:SERIAL NUMBER</td> <td>5.12</td> </tr> <tr> <td>04:COMMUNICATION</td> <td>5.6</td> <td>12:PARTITIONING</td> <td>5.13</td> </tr> <tr> <td>05:OUTPUTS</td> <td>5.7</td> <td>13:OPERATION MOD</td> <td>5.14</td> </tr> <tr> <td>06:CUSTOM NAMES</td> <td>5.8</td> <td><OK> TO EXIT</td> <td></td> </tr> <tr> <td>07:DIAGNOSTICS</td> <td>5.9</td> <td></td> <td></td> </tr> </tbody> </table>		See		See	01:INSTALL CODES	5.3	08:USER SETTINGS	5.10	02:ZONES/DEVICES	5.4	09:FACTORY DEFLT	5.11	03:CONTROL PANEL	5.5	10:SERIAL NUMBER	5.12	04:COMMUNICATION	5.6	12:PARTITIONING	5.13	05:OUTPUTS	5.7	13:OPERATION MOD	5.14	06:CUSTOM NAMES	5.8	<OK> TO EXIT		07:DIAGNOSTICS	5.9			<p>Go to the indicated section of the selected option</p>
	See		See																																
01:INSTALL CODES	5.3	08:USER SETTINGS	5.10																																
02:ZONES/DEVICES	5.4	09:FACTORY DEFLT	5.11																																
03:CONTROL PANEL	5.5	10:SERIAL NUMBER	5.12																																
04:COMMUNICATION	5.6	12:PARTITIONING	5.13																																
05:OUTPUTS	5.7	13:OPERATION MOD	5.14																																
06:CUSTOM NAMES	5.8	<OK> TO EXIT																																	
07:DIAGNOSTICS	5.9																																		

① ① - Entering the "Installer Mode" menu	
[1]	You can access the "Installer Mode" only when the system is disarmed. The process described refers to the case where "User permit" is not required. If "User permit" is required, select the "User Settings" option and ask the Master User to enter his code and then scroll the "User Settings" menu and select the "Installer Mode" option (last option in the menu). Continue to Step 2.
[2]	If you have not already changed your Installer code number, use the default settings: 8888 for installer & 9999 for master installer. If you enter an invalid installer code 5 times, the keypad will be automatically disabled for a pre-defined period of time and the message WRONG PASSWORD will be displayed.
[3]	You have now entered the "Installer Menu". Scroll and select the menu you wish and continue to its corresponding section in the guide (indicated on the right side of each option).

3. WP8010 INSTALLATION

5.2.1 Entering the "Installer Mode" if "User Permit" is enabled

In certain countries the regulations may require **user permission** to make changes in the configuration of the panel. To comply with these regulations, the **"Installer Mode"** option can be accessed only via the **"User Settings"** menu. The Master user must first enter the **"User Settings"** menu then scroll until the **"Installer Mode"** option is shown and then the installer can continue as shown in the above table (see also ⓘ [1] in Step 1 above).

To configure the panel to comply with **user permission** requirements - see option #91 **"User Permit"** in section 5.5.8.

5.2.2 Selecting options

<p>ⓘ ⓘ – Selecting an option from a menu</p> <p>Example: To Select an Option from the "COMMUNICATION" menu:</p> <p>[1] Enter the Installer Menu and select the "04.COMMUNICATION" option (see section 5.2).</p> <p>[2] Select the sub-menu option you need, for example: "3: C.S. REPORTING".</p> <p>[3] Select the parameter you wish to configure for example: "11:RCVR 1 ACCOUNT"</p> <p>[4] To continue, go to the section of the selected sub-menu option, for example section 5.6.4 for the "3:C.S.REPORTING" menu, and look for the sub-menu you wish to configure (e.g. "11:RCVR 1 ACCOUNT"). After configuring the selected parameter the display returns to step 3.</p> <p>To Change the Configuration of the Selected Option:</p> <p>When entering the selected option, the display shows the default (or the previously selected) setting marked with ■.</p> <p>To change the configuration, scroll ▶ the "Options" menu and select the setting you wish and press OK to confirm. When done, the display reverts to Step 3.</p>	
--	--

5.2.3 Exiting the Installer Mode

To exit the Installer Mode, proceed as follows:

Step 1	ⓘ	Step 2	ⓘ	Step 3	ⓘ
	[1]		[2]		[3]
Any screen	⬆ or 🔒	<OK> TO EXIT	OK		READY 12:00

<p>ⓘ ⓘ – Exiting the Installer Mode</p> <p>[1] To exit "INSTALLER MODE", move up the menu by pressing the ⬆ button repeatedly until the display reads "<OK> TO EXIT" or preferably; press the 🔒 button once which brings you immediately to the exit screen "<OK> TO EXIT".</p> <p>[2] When the display reads "<OK> TO EXIT", press ⓘ OK.</p> <p>[3] The system exits the "INSTALLER MODE" menu and returns to the normal disarm state while showing the READY display.</p>	
--	--

5.3 Setting Installer Codes

The WP8010/WP8030 system provides two installer permission levels with separate installer codes, as follows:

- **Master Installer:** The "Master Installer" is authorized to access all Installer Menu and sub-menu options. The default code is: 9999 (*).
- **Installer:** The "Installer" is authorized to access most but not all Installer Menu and sub-menu options. The default code is 8888 (*).
- **Guard Code:** Enables an authorized guard to only Arm Away / Disarm the control panel. The default code is 0000 (*).











The following actions can be performed only by using the **Master Installer code**:

- Changing the Master Installer code.
- Defining specific communication parameters – see **"3:C.S REPORTING"** in sections 5.6.1 and 5.6.4.
- Resetting the WP8010/WP8030 parameters to the default parameters – see **"09:FACTORY DEFLT"** in section 5.11.

Note: Not every system includes a **Master Installer code** feature. In such systems, the **Installer** can access all Installer Menu and sub-menu options the same as a Master Installer.

(*) **You are expected to use the default codes only once for gaining initial access, and replace it with a secret code known only to yourself.**

To change your Master Installer or Installer Codes proceed as follows:

Step 1	Step 2	Step 3	Step 4
Select "01:INSTALL CODES" Option [1]	Select Master Installer , Installer code or Guard code [2]	Enter NEW Master Installer , Installer code or Guard code [3]	
 INSTALLER MODE  ENTER CODE: █  01:INSTALLER CODES 	 NEW MASTER CODE  or NEW INST. CODE  NEW GUARD CODE	 MASTER CODE █999  to step 2 or INST. CODE █888  to step 2 or GUARD CODE █000  to step 2	

① ① – Setting Installer Codes

[1] Enter the **Installer Menu** and select the "01:INSTALL CODES" option (see section 5.2).

[2] Select the "**NEW MASTER CODE**", "**NEW INST. CODE**" or "**NEW GUARD CODE**". Some panels may have only the Installer Code and New Guard Code option.

[3] Enter the new 4-digit Code at the position of the blinking cursor and then press .

Notes:

- Code "0000" is not valid for Master Installer or installer.
- Inserting "0000" for the Installer will delete the Installer Code.
- Warning! Always use different codes for the Master Installer, for the Installer and for the Users.**
If the Master Installer Code is identical to the Installer code, the panel will not be able to recognize the Master Installer. In such a case, you must change the Installer code to a different code. This will re-validate the Master Installer code.

5.3.1 Identical Installer and Master Installer Codes

In a 2-installer code system, the non-master installer may inadvertently change his Installer Code to that of the Master Installer Code. In this case, the panel will allow the change in order to prevent the non-master installer from realizing the discovery of the Master Installer's Code. The next time the Master Installer enters the Installer Mode the Master Installer will be considered as an Installer and not as a Master Installer. In such a case the Master Installer should use one of the following solutions:

- Access the panel using the Remote Programmer PC software application and change the Master Installer Code to a different code than the one programmed by the Installer.
1. Change the Installer Code to a temporary code, 2. exit the Installer Mode, 3. enter the Installer Mode again using the Master Installer code (the Master Installer Code will now be accepted), 4. change the Master Installer code to a different code, 5. and change the NON-Master Installer Code back again (in other words, undo the change to the temporary code) so that the NON-Master Installer can still enter the system.

3. WP8010 INSTALLATION

5.4 Zones / Devices

5.4.1 General Guidance & Zones/Devices Menu Options

The ZONES/DEVICES menu enables you to add new devices to the system, to configure them and to delete them, if required.

To select an option follow the instructions below. Additional details and guidance are provided in section 5.2.

INSTALLER MODE	➡ 02:ZONES/DEVICES	➡ MENU you wish	➡ indicates scroll	▶▶ and select	OK
----------------	--------------------	-----------------	--------------------	---------------	----

Option	Use	Section
ADD NEW DEVICES	Use to enroll and configure the device's operation according to your preference and in case of sensors to also define their zone name (location), zone type and chime operation.	5.4.2
DELETE DEVICES	Use to delete devices from the system and to reset their configuration.	5.4.3
MODIFY DEVICES	Use to review and/or change the device's configuration.	5.4.4
REPLACE DEVICES	Use to replace faulty devices with automatic configuration of the new device.	5.4.5
ADD TO SOAK TEST ¹	Use to enable the Soak Test for device zones.	5.4.6
DEFINE DEFAULTS	Use to customize the defaults of the device's parameters according to your personal preferences for each new device enrolled in the system.	5.4.7

5.4.2 Adding New Wireless Devices or Wired Sensors

Part A - Enrollment

To enroll and configure a device, follow the instructions in the following chart

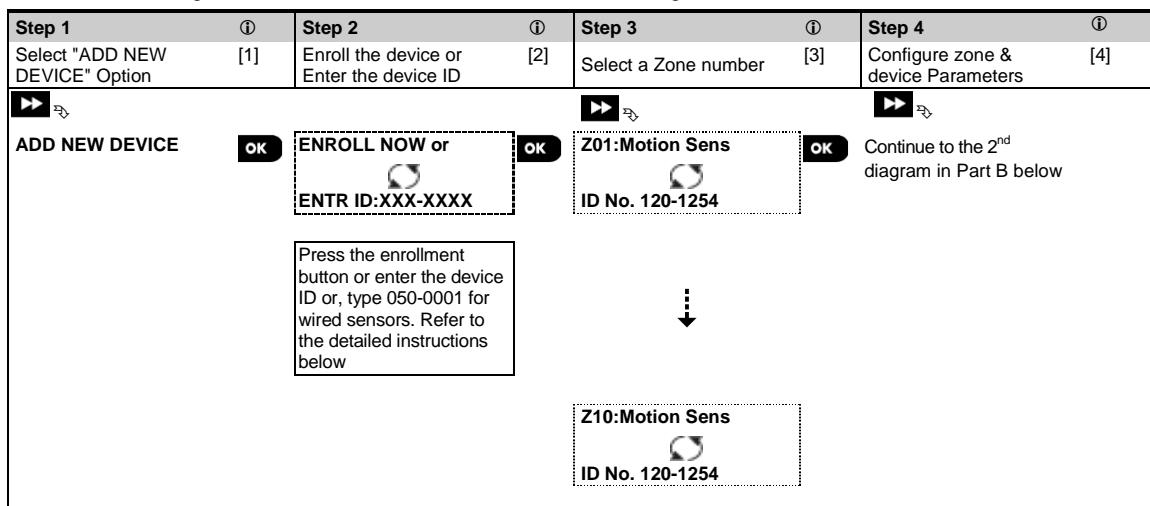

①	① - Adding New Devices
[1]	Enter "INSTALLER MODE", select "02:ZONES DEVICES" (see section 5.2) and then select "ADD NEW DEVICE". Because of encryption, PowerG devices (including Keyfobs) cannot be used on more than one system at one time. Remember to verify panel and device compatibility.
[2]	See enrollment by button or device ID below. If enrollment is successful, the display reads "DEVICE ENROLLED" (or "ID ACCEPTED") and then shows the device details - see [3]. However, if the enrollment fails, the display will advise you the reason for failure, for example: "ALREADY ENROLLED" or "NO FREE LOCATION". If the enrolled device is adapted to operate as another device that the panel recognizes, the display then reads "ADAPTED TO <OK>".
[3]	The display shows the device details and the first available free Zone number for example: "Z01:Motion Sensor > ID No. 120-1254" (or "K01:Keyfob / S01:Siren etc. depending on the type of the enrolled device). Both Wireless and wired detectors can be enrolled in any zone number. To change the zone number, click the ▶▶ button or type in the zone number, and then press ① OK to confirm.
[4]	Continue to Part B to configure the device – see diagram below

¹ Soak Test is not applicable for UL installations.

How to check Panel ↔ Device compatibility

Each PowerG device bears a 7-character Customer ID printed on the device sticker in the format: FFF-M:DDD, (for example, 868-0:012) where FFF is the frequency band and M:DDD is the variant code.

For PowerG system devices compatibility, make sure the frequency band (FFF) and the variant code (M) of the devices match. The DDD can be ignored if the panel displays "ANY" for DDD.

Enrollment by using Device ID

The 7-digit Device ID can be used to register a device into the panel locally or from a remote location using the Remote Programmer PC software. The enrollment by device ID is a 2 stage procedure.

In the 1st stage you register the devices' ID numbers into the panel and complete the device configuration. This can be done from a remote location using the Remote Programmer PC software. Following the 1st stage, the WP8010/WP8030 panel waits for the device to appear on the network in order to complete the enrollment.

In the 2nd stage, the enrollment is completed when the panel is in full working mode by inserting the battery into the device, or by pressing the tamper or enrollment button on the device. This procedure is very useful for adding devices to existing systems without the need to provide technicians with the Installer Code, or to allow access to the programming menus.

Remember! The system will indicate a "**NOT NETWORKD**" trouble until the 2nd stage of all registered devices is completed.

Note: The Soak Test¹ on pre-enrolled zones can be activated only when the zone is fully enrolled.

Enrollment by using the Enrollment button

The panel is set to the Enrollment mode (step #2 above) and the device is enrolled using the Enroll button (refer to the device information in the device Installation Instructions, then open the device and identify the **Enroll button**). For keyfobs and keypads, use the **AUX '*'** button. For gas detectors, **insert the battery**.

Press the enroll button for 2-5 seconds until the LED lights steadily and then release the button. The LED will extinguish or may blink for a few more seconds until the enrollment is completed. If enrollment is successfully completed, the WP8010/WP8030 sounds the "Happy Tune" and the LCD momentarily shows "**DEVICE ENROLLED**" and then reads the device details.

Enrollment of wired sensors

To enroll a **wired sensor** into the wired zone, enter ID: 050-0001 or 050-0002.

¹ Soak Test is not applicable for UL installations.

3. WP8010 INSTALLATION

Part B - Configuration

Step 1	Step 2	Step 3	Step 4
Enter Location Menu [1]	Select Location [2] <i>(see list below)</i>	Enter Zone Type [3]	Select Zone Type [4] <i>(see list below)</i>
Z10:LOCATION	Dining room ↓ Custom 5	Z10:ZONE TYPE	1:Exit/Entry1 ↓ 5. Interior
Step 5	Step 6	Step 7	Step 8
Enter Chime Menu [5]	Select Chime option [6]	Enter Partitions Menu [7]	Select Partition options [8]
Z10:SET CHIME	chime OFF ↓ melody-chime	Z10:PARTITIONS	Z10:P1 P2 P3
Step 9	Step 10	Step 11	
Enter Device Settings Menu [9]	Configure Device Parameters [10]	Continue or End	
Z10:DEV SETTINGS	Refer to device datasheet in the device Installation Instructions for specific configuration instructions.	To continue – See ① [11]	

①	① - Configuring New Devices
	Location (name) setting:
[1]	To review or change the Location (name) setting, press the button, otherwise scroll to the next option.
[2]	To change the Location name, enter the menu and select the name from the " Location List " below. You can assign additional custom names using the " 06.CUSTOM NAMES " option in the Installer menu. See section 5.8. Note: As a shortcut, press the 2 digit serial No. of the Custom Location, which takes you directly to its menu. Zone Type setting:
[3]	To review or change the Zone Type setting, press the button, otherwise scroll to the next option.
[4]	The zone type determines how the system handles signals sent from the device. Press and select a suitable zone type. The list of available Zone Types and the explanation for each zone type is provided below. Note: As a shortcut, press the 2 digit serial No. of the Zone Type shown in the Location List below, which takes you directly to its menu. Chime setting:
[5]	All zones are set to chime OFF by default. To configure the device to cause the panel to sound (when disarmed) a Chime melody when tripped, press the button, otherwise scroll to the next option. Note: For UL Listed Product, the Chime setting must be set to "Chime ON".
[6]	Select between " Chime OFF ", " melody-chime " and " zone name-chime " ¹ . In "melody chime" the control panel sounds a chime melody when the sensor is tripped. In "zone name-chime" the control panel sounds the zone name when the sensor is tripped. The chime operates during the Disarm mode only. Partitions setting:
[7]	Note: The "PARTITIONS" menu appears only if Partitions is enabled in the control panel (see section 5.13).
[7]	When entering the menu, the display shows the default Partition selection (marked with).
[8]	Use the keypad keys to assign partitions to the device. Device Configuration:
[9]	To review or change the Device Configuration (settings) , press the button, otherwise scroll to the next option – see ① [11].
[10]	To configure the device parameters, refer to its corresponding device datasheet in the device Installation Instructions. The defaults of the device parameters can be also configured as explained in section 5.4.7.

¹ Refers to WP8030 only

① ① - **Configuring New Devices**

- [11] After completing the configuration of the device, the wizard brings you to the "**Next Step**" menu with the following 3 options:
"NEXT Device" to enroll the next device.
"MODIFY Same Dev." reverts to Step 1 (i.e. "**LOCATION**") to allow you to perform additional changes to the device, if needed.
"EXIT Enrollment" exits the enrollment procedure and returns to Step 1 bringing you back to the "**ADD NEW DEVICES**" menu.

Location List

No.	Location Name	No.	Location Name	No.	Location Name	No.	Location Name
01	Attic	09	Downstairs	17	Living room	25	Master bath*
02	Back door	10	Emergency	18	Office	26	Master Bdrm*
03	Basement	11	Fire	19	Upstairs	27	Custom 1*
04	Bathroom	12	Front Door	20	Utility room	28	Custom 2*
05	Bedroom	13	Garage	21	Yard	29	Custom 3*
06	Child room	14	Hall	22	Dining room*	30	Custom 4*
07	Closet	15	Kitchen	23	Garage door*	31	Custom 5*
08	Den	16	Laundry room	24	Guest room*		

WP8010: All location names be customized by "06:CUSTOM NAMES" menu (see section 5.8)

* **WP8030:** Can be customized by "06:CUSTOM NAMES" menu (see section 5.8)









Zone Type List

No.	Zone Type	Description
1.	Exit/Entry 1	This Zone starts the exit time when the user arms the system or the entry time when the system is armed. To configure the Exit/Entry 1 time, see sections 5.5.1 & 5.5.2 - Installer menu " 03.CONTROL PANEL " options 01 and 03. (*)
2.	Exit/Entry 2	Same as Exit / Entry 1 but with a different delay time. Used sometimes for entrances closer to the panel. For configuring the Exit and Entry 2 delays, see sections 5.5.1 & 5.5.2 – Installer menu " 03.CONTROL PANEL " options 02 and 03. (*)
3.	Home Delay	Used for Door/Window Contacts and Motion sensors protecting entrance doors to interior living areas where you wish to move freely when the system is armed HOME. Functions as a "Delayed" zone when the system is armed HOME and as a "Perimeter Follower" zone when the system is armed AWAY.
4.	Inter-Follow	Similar to "Interior" zone but temporarily ignored by the alarm system during entry/exit delay periods. Usually used for sensors protecting the route between the entrance door and the panel. Note: CP-01 features not to be enabled in UL Listed product.
5.	Interior	This zone type generates an alarm only when the system is armed AWAY but not when the system is armed HOME. Used for sensors, installed in interior areas of the premises, that need to be protected when people are not present inside the premises.
6.	Perimeter	This zone type generates an alarm when the system is armed both in AWAY and HOME modes. Used for all sensors protecting the perimeter of the premises.
7.	Perim-Follow	Similar to "Perimeter" zone, but is temporarily ignored by the alarm system during entry/exit delay periods. Usually used for sensors protecting the route between the entrance door and the control panel. Note: CP-01 features not to be enabled in UL Listed product.
8.	24h silent	This zone type is active 24 hours, even when system is DISARMED. It is used to report alarm events from sensors or manually activated buttons to the monitoring station or private telephones (as programmed) without activating the sirens.
9.	24h audible	Similar to 24hr silent zone, but also provides an audible siren alarm. Note: This zone type is used only for burglary applications.
10.	Emergency	This zone type is active 24 hours, even when the system is DISARMED. It is used to report an emergency event and to initiate an Emergency call to the monitoring stations or private telephones (as programmed). Note: For UL Listed product, Emergency is for ancillary use only.
11.	Arming Key	An Arming key zone is used to control the arming and disarming of the system. by an external wired system or simple keyswitch connected to the panel's wired zone input or a wired input of a PowerG device.



3. WP8010 INSTALLATION

No.	Zone Type	Description
		<p>Notes:</p> <p>1. If the wired input of the panel or PowerG device is closed, the control panel will be armed. If it is opened, the control panel will be disarmed - refer to Figure 3.6b (WP8010/4.9b WP8030).</p> <p>2. Arming Key not to be enabled in UL Listed product.</p>
12.	Non-Alarm	This zone does not create an alarm and is often used for non-alarm applications. For example, a detector used only for sounding a chime.
13.	Fire	A Fire zone is used for connecting the MC-302E (magnetic contact with hard-wired input) to a wired smoke detector.
17.	Guard keybox	A Guard keybox zone is usually connected to a metal safe containing the physical keys needed to enter the building. Following an alarm, the safe becomes available to a trusted Guard who can open the Guard keybox, obtain the keys and enter the secured premises. The Guard keybox zone acts just like a 24H audible zone. The Guard keybox zone also provides automatic audible internal and external siren alarm that is immediately reported to the Monitoring Station (and does not depend on the Abort Time).
		<p>Note: Opening/closing the Guard keybox causes the WP8010/WP8030 to signal the Monitoring Station.</p>
18	Outdoor	A zone for outdoor areas where an activated alarm does not indicate intrusion into the house.
		<p>Note: The PIR camera / Outdoor PIR camera detector cannot be set to Outdoor Zone Type.</p>
(*)		These Zone types are useful mainly when you arm and disarm the system from inside the protected premises. If you arm and disarm the system from outside (without tripping any sensor), such as using a keyfob, it is preferred to use the other Zone Types.

5.4.3 Deleting a Device









Step 1	Step 2	Step 3	Step 4	Step 5
Select "DELETE DEVICES" Option [1]	Select the respective device Group [2]	Select exact device you wish to delete [3]	To delete the device: press the  key [4]	
 02:ZONES DEVICES ↓ DELETE DEVICES 	 CONTACT SENSORS ↓ MOTION SENSORS 	 Z01:Motion Sens ID No. 120-1254 	<OFF> to delete 	↶ to step 2

① ① – Deleting a Device

- [1] Enter the **Installer Menu**, select the "02.ZONES/DEVICES" option (see section 5.2) and then select the "DELETE DEVICES" option.
- [2] Select the respective group of the device you wish to delete. For example, "MOTION SENSORS".
- [3] Scroll the Device Group, identify (by zone and/or ID number) the exact device you wish to replace, for example: "Z01: Motion Sensor > ID No. 120-1254" and press the  button.
- [4] The display prompts you "<OFF> to delete". To delete the device, press the  (OFF) button.

5.4.4 Modifying or Reviewing a Device

To **Modify** or **Review** the device parameters proceed as follows:

Step 1	Step 2	Step 3	Step 4	Step 5
Select "MODIFY DEVICES" Option [1]	Select the respective device Group [2]	Select exact device you wish to modify [3]	Select the Parameter you wish to modify [4]	Modify the Parameter
				
02:ZONES DEVICES ↓ MODIFY SENSORS 	CONTACT SENSORS ↓ MOTION SENSORS 	Z10:Motion Camra  ID No. 140-1737 	Z10:LOCATION Z10:ZONE TYPE Z10:SET CHIME Z10:PARTITIONS Z10:DEV SETTINGS 	See ① [4] When done → to step 2









① ① – Modifying or Reviewing a Device

- [1] Enter the **Installer Menu**, select the "02:ZONES/DEVICES" option (see section 5.2) and then select the "MODIFY DEVICES" option.
- [2] Select the respective group of the device you wish to review or modify. For example, "MOTION SENSORS".
- [3] Scroll the Device Group, identify (by zone and/or ID number) of the exact device you wish to modify or review, for example: "Z10:Motion Camra > ID No. 140-1737".
- [4] From here on the process is same as the configuration process that follows the enrollment of that device. To continue, refer to Section 5.4.2 "Adding a New Wireless Device" Part B. When done, the display will show the next device of the same type (i.e. "Motion camera").

5.4.5 Replacing a Device

Use this option to replace a faulty device that is enrolled in the system with another device of the same type number (i.e. same first 3 digit of the ID number – see section 5.4.2.A) while keeping the same configuration of the original device. There is no need to delete the faulty device or to reconfigure the new device. Once enrolled, the new device will be configured automatically to the same configuration of the faulty (replaced) device.

To **Replace**, a device proceed as follows:

Step 1	Step 2	Step 3	Step 4	Step 5
Select "REPLACE DEVICES" Option [1]	Select the respective device Group [2]	Select exact device you wish to replace [3]	Enroll the new device [4]	
				
02:ZONES/DEVICES ↓ REPLACE DEVICES 	CONTACT SENSORS ↓ KEYFOBS 	K03:Keyfob  ID No. 300-0307 	ENROLL NOW or  ENTR ID:300-XXXX 	See ① [4].

① ① – Replacing a Device

- [1] Enter the **Installer Menu**, select the "02:ZONES/DEVICES" option (see section 5.2) and then select the "REPLACE DEVICES" option.
- [2] Select the respective group of the device you wish to replace. For example, "KEYFOBS".
- [3] Scroll the Device Group, identify (by zone and/or ID number) the exact device you wish to replace, for example: "K03: Keyfob > ID No. 300-0307".
If you try enrolling a new device of a different type than the replaced device, the WP8010/WP8030 will reject the new device and the display will read "WRONG DEV.TYPE".
When done, the display shows the device details of the new device.

3. WP8010 INSTALLATION

5.4.6 Configuring Soak Test Mode¹

This option enables you to enter device zones into Soak Test mode.

To **Enable** the Soak Test proceed as follows:

Step 1	Step 2	Step 3	Step 4	Step 5
Select "ADD TO SOAK TEST" Option [1]	Select the respective device Group [2]	Select device zone number [3]	Select to enable or disable the Soak Test [4]	[5]
02:ZONES/DEVICES ↓ ADD TO SOAK TEST	CONTACT SENSORS ↓ MOTION SENSORS	Z09:Motion Sens ↓ ID No. 120-2468	Disable test Enable test	See ① [5] ↳ to Step 3

① ① – Enabling Soak Test mode
[1] Enter the Installer Menu , select the "02.ZONES/DEVICES" option (see section 5.2) and then select the "ADD TO SOAK TEST" option.
[2] Select the respective Group of the device you wish to add the Soak Test. For example, " MOTION SENSORS ".
[3] Scroll to select the specific device zone number.
[4] Select between " Disable test " (default) or " Enable test ".
[5] If set to " Enable Test " you must set the duration of the Soak Test before the Soak Test will start (see section 5.5.8). You can stop the test for the relevant zone by changing the setting to " Disable test " at any time during the testing period. All Soak test zones will be reset to start a new test upon occurrence of one of the following: 1) Power up of the system; 2) Setup of Factory Default; 3) Change in system Soak Time.

5.4.7 Defining Configuration Defaults for "Device Settings"

WP8010/WP8030 enables you to define the **Default Parameters** used during enrollment and to change them whenever you wish so that new devices enrolled into the system will be configured automatically with these default parameters without the need to modify the configuration of each new enrolled device. You can use a certain set of defaults for certain group of devices and then change the defaults for another group.

IMPORTANT! Devices that were already enrolled in the WP8010/WP8030 system before the defaults have been changed will not be affected by the new default settings.

To **Define** the Default parameters of a device Group proceed as follows:

Step 1	Step 2	Step 3	Step 4	Step 5
Select "DEFINE DEFAULTS" Option [1]	Select the respective device Group [2]	Select the Default Parameter [3]	Select the new Default Setting [4]	[5]
02:ZONES/DEVICES ↓ DEFINE DEFAULTS	CONTACT SENSORS ↓ MOTION SENSORS	Alarm LED Event Counter Disarm Activity ↓	Low High	See ① [5] ↳ to Step 3

① ① – Changing Defaults
[1] Enter the Installer Menu , select the "02.ZONES/DEVICES" option (see section 5.2) and then select the "DEFINE DEFAULTS" option.
[2] Select the respective Group of the device you wish to define its defaults. For example, " MOTION SENSORS ".
[3] Scroll the parameter list of the Device Group and select the Default Parameter you wish to change, for example: " Event Counter ". The list combines the parameters of all devices in the group, for example, the parameters of all types of Motion sensors.
[4] In the example, the existing default setting of the "Event Counter" for enrolled motion sensors was "Low Sensitivity" (marked with). To change it to " High ", scroll the menu until the display shows " High " and press the button. The new default for the Event Counter parameter setting of Motion Sensors enrolled from now on will be " High ".
[5] The new default does not affect motions sensors that were already enrolled before the change was made but only new motion sensors that will be enrolled in the WP8010/WP8030 after the change is performed.

¹ Soak Test is not applicable for UL installations

5.4.8 Updating Devices after Exiting Installer Mode

When exiting the "Installer mode", the WP8010/WP8030 panel communicates with all devices in the system and updates them with the changes that have been performed in their "Device Settings" configuration. During the updating period, the display indicates "DEV UPDATING 018" where the number (for example, 018) is a countdown of the remaining number of devices yet to be updated.

5.5 Control Panel

5.5.1 General Guidance – "Control Panel" Flow-Chart & Menu Options

The "CONTROL PANEL" menu enables you to configure and customize the operation of the control panel. The "CONTROL PANEL" menu provides you with configurable parameters divided into several groups, each dealing with certain aspects of the system operations as follows (see detailed list in Step 2 of the chart below):

Group	Description of Group Features and Parameters	Section
Arming/Disarming and Exit/Entry Procedures	Contains configurable features and parameters related to Arming and Disarming of the system and the Exit and Entry procedures.	5.5.2
Zone Behavior	Contains configurable features and parameters related to the functionality of the Zones.	5.5.3
Alarms & Troubles	Contains configurable features and parameters related to initiating, canceling and reporting of Alarm and Trouble events.	5.5.4
Sirens	Contains configurable features and parameters common to all sirens in the system.	5.5.5
User Interface	Contains configurable features and parameters related to the functionality of the panel's audible and visual indications.	5.5.6
Jamming & Supervision	Contains configurable features and parameters related to detecting and reporting of RF Jamming and device Supervision (missing device) events.	5.5.7
Miscellaneous	Contains a variety of other configurable features and parameters related to the system.	5.5.8

3. WP8010 INSTALLATION

To enter the "03.CONTROL PANEL" menu and to select and configure an option, proceed as follows:

Step 1	Step 2	Step 3
Select "CONTROL PANEL" option	Select the "Control Panel" Parameter you wish to configure	Configure option
<p>▶ INSTALLER MODE</p> <p>▶ 03.CONTROL PANEL OK</p>	<p>▶ Arming & Disarming 5.5.2</p> <p>▶ Zone Behavior 5.5.3</p> <p>▶ Alarms & Troubles 5.5.4</p> <p>▶ Sirens 5.5.5</p> <p>▶ User Interface 5.5.6</p> <p>▶ Jamming and Supervision 5.5.7</p> <p>▶ Miscellaneous 5.5.8</p>	<p>▶ 01:ENTRY DELAY1</p> <p>▶ 02:ENTRY DELAY2</p> <p>▶ 03:EXIT DELAY</p> <p>▶ 04:EXIT MODE</p> <p>▶ 05:QUICK ARM</p> <p>▶ 06:BYPASS ARM</p> <p>▶ 07:LATCHKEY ARM</p> <p>▶ 08:DISARM OPTION</p> <p>▶ 09:ARMING KEY</p> <p>▶ 31:PANIC ALARM</p> <p>▶ 32:DURESS ALARM</p> <p>▶ 33:INACTIVE ALRT</p> <p>▶ 34:TAMPER ALARM</p> <p>▶ 35:AC FAIL REPRT</p> <p>▶ 36:CONFIRM ALARM</p> <p>▶ 37:ABORT TIME</p> <p>▶ 38:CANCEL ALARM</p> <p>▶ 39:ALARM RESET</p> <p>▶ 40:ABORT FIRE T.</p> <p>▶ 51:PIEZO BEEPS</p> <p>▶ 52:TROUBLE BEEPS</p> <p>▶ 53:MEMORY PROMPT</p> <p>▶ 54:LOW-BAT ACK</p> <p>▶ 55:BACK LIGHT</p> <p>▶ 56:SCREEN SAVER</p> <p>▶ 61:JAM DETECT</p> <p>▶ 62:MISSING REPRT</p> <p>▶ 63:NOT READY</p> <p>▶ 64:MISS/JAM ALRM</p> <p>▶ 65:SMOK FAST MIS</p> <p>▶ 75:CODE VERSION¹</p> <p>▶ 91:USER PERMIT</p> <p>▶ 92:BATTERY TYPE</p> <p>▶ 93:SOAK PERIOD²</p> <p>OK Go to the indicated group section of the selected option</p> <p>OK When done → to Step 2</p> <p>OK</p>

5.5.2 Configuring Arming/Disarming and Exit/Entry Procedures

The following table provides you with a detailed description of each option and its configuration settings. To select an option and change its configuration – refer to section 5.5.1.

Option	Configuration Instructions
01:ENTRY DELAY1 02:ENTRY DELAY2	<p>Two different entry delays allow the user to enter the protected site (while the system is in the armed state) via dedicated exit/entry doors and routes without causing an alarm. Following entry, the user must disarm the control panel before the entry delay expires. Slow-rate warning beeps start sounding once the door is opened, until the last 10 seconds of the delay, during which the beeping rate increases. The "ENTRY DELAY 1" and "ENTRY DELAY 2" options allow you to program the time length of these delays.</p> <p>Options: 00 seconds; 15 seconds (default for entry delay 2); 30 seconds (default for entry delay 1); 45 seconds; 60 seconds; 3 minutes and 4 minutes.</p> <p>Notes:</p> <ol style="list-style-type: none"> 1. In some WP8010/WP8030 variants, these menus are displayed in the Operation Mode only (see section 5.14). 2. To comply with UL requirements, the entry delay must not exceed 15 sec unless a keypad is used. If a keypad is used, the entry delay shall not exceed 45 seconds.

¹ Code Version is not applicable for UL installations

² Soak Test is not applicable for UL installations

Option	Configuration Instructions
	<p>3. To comply with CP-01 requirements, "00s" and "15s" delays must not be used. CP-01 features not to be enabled in UL Listed product.</p> <p>4. To comply with EN requirements, the entry delay must not exceed 45 sec.</p>
03:EXIT DELAY	<p>This option allows programming the time length of the exit delay. An exit delay allows the user to arm the system and leave the protected site via specific routes and exit/entry doors without causing an alarm. Slow-rate warning beeps start sounding once the arming command has been given, until the last 10 seconds of the delay, during which the beeping rate increases.</p> <p>Options: 30 seconds; 60 seconds (default); 90 seconds; 120 seconds, 3 minutes and 4 minutes.</p> <p>Notes:</p> <ol style="list-style-type: none"> 1. To comply with UL requirements, do not set to 3 min or 4 min. 2. To comply with CP-01 requirements, the "30s" delay must not be used. CP-01 features not to be enabled in UL Listed product.
04:EXIT MODE	<p>The "Exit Delay" time can be further adjusted according to your preferred exit route. The control panel provides you with the following "Exit Mode" options:</p> <p>A: "normal" - The exit delay is exactly as defined.</p> <p>B: "restrt+arm home" - Exit delay restarts when the door is reopened during exit delay. If no door was opened during exit delay "AWAY", the control panel will be armed "HOME".</p> <p>C: "restart-reentry" - The exit delay restarts when the door is reopened during exit delay. The restart occurs once only. Restarting the exit delay is helpful if the user re-enters immediately after going out to retrieve an item that he left behind.</p> <p>D: "end by exit" - The exit delay expires (ends) automatically when the exit door is closed even if the defined exit delay time was not completed.</p> <p>Options: normal (default); restrt+arm home; restart>reentry and end by exit.</p> <p>Note: In some WP8010/WP8030 variants, this menu is displayed in the Operation Mode only (see section 5.14).</p>
05:QUICK ARM	<p>Define whether or not the user will be allowed to perform quick arming or not. Once quick arming is permitted, the control panel does not request a user code before it arms the system.</p> <p>Options: OFF (default) and ON (default in USA).</p>
06:BYPASS ARM	<p>Define whether or not the user will be allowed to manually bypass individual zones, or allow the system to perform automatic bypassing of open zones during the exit delay (i.e. "force arm"). If a zone is open and "forced arming" is not permitted, the system cannot be armed and "NOT READY" is displayed. If "no bypass" is selected, neither manual bypassing nor force arming is allowed which means that all zones must be secured before arming.</p> <p>Options: no bypass (default); force arm and manual bypass (default in USA).</p> <p>Notes:</p> <ol style="list-style-type: none"> 1. To comply with EN requirements, "manual bypass" must be selected. 2. The option "force arm" is not applicable in the UK. 3. "force arm" or "automatic bypass" feature is not allowed in UL installations; only "manual bypass" must be enabled. For manual bypass, audible trouble may be silenced. 4. A zone in Soak Test¹ mode that is configured as bypass will trigger a test fail event if the system detects a potential alarm event. 5. There is no limit of reported events when a bypass zone is in Soak Test¹ mode.
07:LATCHKEY ARM	<p>When "ON", a "latchkey" message will be reported by voice² or SMS message to users (see Note) upon disarming by a "latchkey user" (users 5-8 or keyfob transmitters 5-8 in WP8010system / users 23-32 or keyfob transmitters 23-32 in WP8030system). This mode is useful when parents at work want to be informed of a child's return from school.</p> <p>Options: OFF (default) and ON.</p> <p>Notes:</p> <p>To enable the reporting, you must configure the system to report "alt" events to Private users (Latchkey belongs to the "alerts" group of events). Refer to section 5.6.5 "REPORTED EVENTS" option in both "VOICE REPORT" & "SMS REPORT" menus.</p> <p>Latchkey Arming is supplemental in UL installations.</p>

¹ Soak Test is not applicable for UL installations.

² Refers to WP8030 with voice option only

3. WP8010 INSTALLATION

Option	Configuration Instructions
08:DISARM OPTION	<p>Certain regulations require that when the system is armed in AWAY mode, it may not be disarmed from the outside of the house (such as by keyfobs) before entering the protected premises and activating an "Entry Delay" zone. To answer this requirement, the WP8010/WP8030 provides you with the following configurable options to disarm the system:</p> <p>A: At "any time" (default), the system can be disarmed at all times from all devices.</p> <p>B: During entry delay, the system can be disarmed only using keyfob or prox operated devices ("on entry wrless").</p> <p>C: During entry delay by code, the system can be disarmed only using WP8010/WP8030 panel keypad ("entry + away kp.").</p> <p>D: During entry delay, the system can be disarmed using keyfobs or by code using the WP8010/WP8030 panel keypad ("on entry all.").</p> <p>Note: <i>In some WP8010/WP8030 variants, this menu is displayed in the Operation Mode only (see section 5.14).</i></p>
09:ARMING KEY	<p>Determine that, when activated, the Arming Key will arm AWAY or HOME.</p> <p>Options: arm AWAY (default) and arm HOME.</p> <p>Note: <i>Arming Key not to be enabled in UL Listed product.</i></p>

5.5.3 Configuring Zones Functionality

The following table provides you with a detailed description of each option and its configuration settings. To select an option and change its configuration – refer to section 5.5.1.

Option	Configuration Instructions
21:SWINGER STOP	<p>Define the number of times a zone is allowed to initiate an alarm within a single arming/disarming period (including tamper & power failure events of detectors, etc.). If the number of alarms from a specific zone exceeds the programmed number, the control panel automatically bypasses the zone to prevent recurrent siren noise and excessive reporting to the Monitoring Station. The zone will be reactivated upon disarming, or 8 hours after having been bypassed (if the system remains armed).</p> <p>Options: after 1 alarm (default); after 2 alarms (default in USA); after 3 alarms and no stop.</p> <p>Notes:</p> <ol style="list-style-type: none">1. <i>CP-01 was tested and certified by ETL/Intertek.</i>2. <i>CP-01 features not to be enabled in UL Listed product.</i>3. <i>When a detector is in Soak Test¹ mode and also set to bypass, Swinger Stop will not prevent the sending of events. This may result in excessive reporting of Soak Fail events.</i>
22:CROSS ZONING	<p>Define whether cross zoning will be active "ON" or inactive "OFF" (default). Cross zoning is a method used to counteract false alarms - an alarm will be initiated only when two adjacent zones (zone couples) are violated within a 30-second time window.</p> <p>This feature is active only when the system is armed AWAY and only with respect to the following zone couples: 18+19, 20+21, 22+23, 24+25, 26+27 in WP8010/WP8030system / 40+41, 42+43, 44+45, 46+47, 48+49, 50+51, 52+53, 54+55, 56+57, 58+59, 60+61, 62+63 in WP8010/WP8030.</p> <p>Notes:</p> <ol style="list-style-type: none">1. <i>If one of the two crossed zones is bypassed (see Section 5.5.2), the remaining zone will function independently.</i>2. <i>It is recommended that crossed zones will be only zones used for detection of burglary i.e. "Zone Types": Entry/ Exit, Interior, Perimeter and Perimeter follower.</i>3. <i>CP-01 was tested and certified by ETL/Intertek.</i>4. <i>CP-01 features not to be enabled in UL Listed product.</i>5. <i>If a cross zone is in Soak Test¹ mode, then each zone of this zone couple functions independently.</i> <p>Important! <i>Do not define "cross zoning" to any other zone types such as Fire, Emergency, 24h audible, 24h silent etc.</i></p>

5.5.4 Configuring Alarms & Troubles

The following table provides you with a detailed description of each option and its configuration settings. To select an option and change its configuration – refer to section 5.5.1.

Option	Configuration Instructions
31: PANIC ALARM	<p>Define whether or not the user will be allowed to initiate a Panic Alarm from keypads (by simultaneous pressing the two "Panic Buttons") or keyfobs (by simultaneous pressing the "Away" + "Home" buttons) and whether the alarm will be "silent" (i.e. only reporting of the event) or also audible (i.e. the sirens will also sound).</p> <p>Options: audible (default); silent and disabled.</p>
32: DURESS ALARM (not applicable in UK)	<p>A duress (ambush) alarm message can be sent to the Monitoring Station if the user is forced to disarm the system under violence or menace. To initiate a duress message, the user must disarm the system using a duress code (2580 by default).</p> <p>To change the code, enter the new 4-digit of the new Duress code at the position of the blinking cursor or enter 0000 to disable the duress function and then press OK.</p> <p>Note: <i>The system does not allow programming a duress code identical to an existing user code.</i></p>
33: INACTIVE ALERT	<p>If no sensor detects movement in interior zones at least once within the defined time window, an "inactive alert" event is initiated.</p> <p>Define the time window for monitoring the lack of motion.</p> <p>Options: disabled (default); after: 3/6/12/24/48/72 hours</p>
34: TAMPER ALARM	<p>Define whether the Tamper switch protection of all zones and other peripheral devices (except the control panel) are "active" (default) or "not active".</p> <p>Warning: <i>If you select "not active", be aware that no alarm or report will be initiated in case of tampering with any of the system peripheral devices.</i></p> <p>Note: <i>Tamper alarm must be active in UL Listed product.</i></p>
35: AC FAIL REPRT	<p>To avoid nuisance reporting in case of short interruptions in the house of AC power, the system reports an AC Fail message only if the AC power does not resume within a pre-determined time delay.</p> <p>Options: after 5 minute (default), after 30 minute, after 60 minute or after 3 hours.</p> <p>Notes: <i>To comply with EN requirements, the time delay must not exceed 60 min. Not tested by UL, tested by Intertek.</i></p>
36: CONFIRM ALARM	<p>If two successive alarm events occur within a specific time window, the system can be configured to report the second alarm event as a "confirmed alarm" (see section 5.6.4 option 61). You can activate this feature and set the respective time window.</p> <p>Options: disable (default in USA); in 30/45/60 (default)/90 minutes</p> <p>Notes:</p> <ol style="list-style-type: none"> <i>In some WP8010/WP8030 variants, this menu is displayed in the Operation Mode only (see section 5.14).</i> <i>CP-01 was tested and certified by ETL/Intertek.</i> <i>CP-01 features not to be enabled in UL Listed product.</i>
37: ABORT TIME	<p>The WP8010/WP8030 can be configured to provide a delay before reporting an alarm to the monitoring station (not applicable to alarms from 24H SILENT and EMERGENCY zones). During this delay period, the siren sounds but the alarm is not reported. If the user disarms the system within the delay time, the alarm is aborted. You can activate the feature and select the "Abort Time" interval.</p> <p>Options: in 00 (default in USA)/15/30 (default)/45/60 seconds; in 2/3/4 minutes</p> <p>Notes:</p> <ol style="list-style-type: none"> <i>In some WP8010/WP8030 variants, this menu is displayed in the Operation Mode only (see section 5.14).</i> <i>To comply with UL or CP-01 requirements, the abort time must not exceed 45 sec. CP-01 features not to be enabled in UL Listed product.</i>
38: CANCEL ALARM	<p>The WP8010/WP8030 can be configured to provide a "Cancel Alarm" time window that starts upon reporting an alarm to the Monitoring Station. If the user disarms the system within that "cancel alarm" time, a "cancel alarm" message is sent to the Monitoring Station indicating that</p>

3. WP8010 INSTALLATION

Option	Configuration Instructions
	<p>the alarm was canceled by the user.</p> <p>Options: not active (default in USA); in 1/5 (default)/15/60 minute(s) and in 4 hours.</p> <p>Notes:</p> <ol style="list-style-type: none"> <i>In some WP8010/WP8030 variants, this menu is displayed in the Operation Mode only (see section 5.14).</i> <i>To comply with CP-01 requirements, "1 minute" option must not be used. CP-01 features not to be enabled in UL Listed product.</i> <i>Since the Soak Test¹ zone does not report an alarm event to the Monitoring Station, the WP8010/WP8030 will not send a "cancel alarm" message to the Monitoring Station even if disarmed within the Cancel Alarm period.</i>
39:ALARM RESET	<p>The WP8010/WP8030 provides you with the following Configurable options for resetting the alarm condition and rearming the system:</p> <p>By the user as usual - by user (default). By the engineer (installer) by entering and exiting the "Installer Mode" by entering and exiting the Event Log using the Installer Code or by accessing the system remotely via the telephone using the Installer Code (by engineer). For accessing the system via the telephone, see the User's Guide, Chapter 7 – "Remote Control by Telephone" and use the installer code instead of the user code.</p> <p>Notes:</p> <ol style="list-style-type: none"> <i>This feature is not applicable in the USA.</i> <i>This feature is not to be not to be enabled in UL Listed product.</i>
40:ABORT FIRE T.	<p>Select the length of time allowed by the system to abort a Fire alarm. The WP8010/WP8030 is able to provide an "abort interval" that starts upon detection of a Fire event. During this interval, the buzzer sounds a warning but the siren remains inactive and the alarm is not reported. If the user disarms the system within the allowed abort interval, the alarm is aborted.</p> <p>Options: in 00 (default)/30/60/90 seconds</p>

5.5.5 Configuring Sirens Functionality









The following table provides you with a detailed description of each option and its configuration settings. To select an option and change its configuration – refer to section 5.5.1.

Option	Configuration Instructions
43:PANEL SIREN	<p>Determine whether the control panel's built-in siren will sound alarms – "ON" (default) or remain silent – "OFF".</p> <p>Notes:</p> <ol style="list-style-type: none"> <i>Panel siren must be enabled unless an external sounder is connected to the product.</i> <i>For UL installations, when set to "OFF" the SR-720 PG2 and SR-730 PG2 sirens must be connected.</i>
44:SIREN TIME	<p>Define the period of time the sirens will sound upon alarm.</p> <p>Options: 1/3/4 (default)/8/10/15/20 minute(s).</p> <p>Notes:</p> <ol style="list-style-type: none"> <i>To comply with EN requirements, the "Siren Time" must not exceed 15 minutes.</i> <i>For Canada, the "Siren Time" must be set to 8 minutes</i> <i>In UL installations, set siren time to 4 minutes min.</i>
45:STROBE TIME	<p>Define the length of time the strobe light will flash upon alarm.</p> <p>Options: 5/10/20 (default)/40/60 minutes.</p>
46:SIREN ON LINE	<p>Determine if the siren will be activated when the phone line fails and the system is armed.</p> <p>Options: disable on fail (default) or enable on fail.</p>

¹ Soak Test is not applicable for UL installations.

5.5.6 Configuring Audible & Visual User Interface

The following table provides you with a detailed description of each option and its configuration settings. To select an option and change its configuration – refer to section 5.5.1.

Option	Configuration Instructions
51:PIEZO BEEPS With Partition disabled	<p>Define whether the panel will sound the exit/entry warning beeps during exit and entry delays or not. An additional option is to mute the warning beeps only when the system is armed "HOME".</p> <p>Options: ON (default), OFF when home (default in USA) and OFF, and OFF exit home.</p> <p>Note: <i>When exit beeps are OFF, the happy (success) melody will still sound toward the end of an exit delay.</i></p> <p><i>The volume level of the exit / entry beeps can be modified by pressing the  button on the keypad to increase the volume, or by pressing the  button to decrease the volume.</i></p>
51:PIEZO BEEPS With Partition enabled	<p>Define whether the panel will sound the exit/entry warning beeps during exit and entry delays or not. An additional option is to mute the warning beeps only when the system is armed "HOME".</p> <p>The control panel's display is: Def:P1<input type="checkbox"/> P2<input type="checkbox"/> P3<input type="checkbox"/></p> <p>The pushbuttons , , and  provide selection of the corresponding partitions. Pressing each button repeatedly will toggle between each option.</p> <p>Options: <input type="checkbox"/> (enable beeps), H (OFF when home), h (OFF exit home) and <input type="checkbox"/> (disable beeps).</p> <p>Notes: <i>When exit beeps are OFF, the happy (success) melody will still sound toward the end of an exit delay.</i></p> <p><i>The volume level of the exit / entry beeps can be modified by pressing the  button on the keypad to increase the volume, or by pressing the  button to decrease the volume.</i></p>
52:TROUBLE BEEPS	<p>Under trouble conditions, the panel sounder emits a series of 3 short reminder beeps once per minute. Define whether to enable or disable this reminder beeping or just disable it at night. The "night" hours are defined in the factory but are usually from 8 PM (20:00) until 7:00 AM.</p> <p>Options: ON (default in USA); OFF at night (default) and OFF.</p> <p>Note: <i>Audible trouble beeps to be enabled for UL Listed product.</i></p>
53:MEMORY PROMPT	<p>Define whether or not the user will receive "Memory" LCD indication that an alarm has been activated. By pressing the  button in standby mode, you can view details of the alarm memory.</p> <p>Options: ON (default) and OFF.</p> <p>Note: <i>For UL installations, set to "ON".</i></p>
54:LOW-BAT ACK	<p>You can activate or deactivate the "Low Battery Acknowledge" requirement from the user whose keyfob's battery is low. For further information, see WP8010/WP8030 User's Guide Chapter 5.</p> <p>Options: OFF (default) – acknowledge not needed; ON – acknowledge required.</p> <p>Note: <i>For UL installations, Low Battery Acknowledge must be set to "ON".</i></p>
55:BACK LIGHT	<p>Define whether the panel's back lighting will remain on at all times or will turn on only when a key is pressed and turn off within 10 seconds if no further keystrokes are sensed.</p> <p>Options: always ON and OFF after 10 sec (default).</p>
56:SCREEN SAVER With Partition disabled	<p>The Screen Saver option (when activated) replaces the status display with "WP8010/WP8030" display if no key is pressed during more than 30 seconds. You can activate the Screen Saver and determine whether the status display will resume following any key press (refresh by Key) or by entering a code (refresh by Code). If refresh by Key is selected, the first pressing of any key (except Fire and Emergency) will produce the status display and the second press will perform the key function. For further information, see the User's Guide, Chapter 1, "Screen Saver Mode".</p> <p>Options: OFF (default); refresh by Code and refresh by Key.</p>

3. WP8010 INSTALLATION

Option	Configuration Instructions
56:SCREEN SAVER With Partition enabled	Notes: 1. To comply with EN requirements, "refresh by code" must be selected. 2. For Fire and Emergency keys, the first key press will produce the status display and will also perform the Fire/Emergency function.
	Certain regulations require that the system status display will not be exposed to unauthorized persons. The Screen Saver option (when activated) replaces the system status indication on the LCD with idle text if no key is pressed during more than 30 seconds.
	You can activate the Screen Saver option and determine whether the status display will resume following any key press (Text - by Key) or by entering a code (Text - by Code). If Text by Key is selected, the first pressing of any key (except Fire and Emergency) will produce the status display and the second press will perform the key function. Regarding the Fire and Emergency keys, the first key press will produce the status display and will also perform the Fire/Emergency function.
	You can also determine that if no key is pressed during more than 30 seconds the date and time will appear on the display. You can determine that normal display will return after pressing the  button followed by entering user code (Clock - by Code) or after pressing any key (Clock - by Key). For further information, see the User's Guide, Chapter 1, "Screen Saver Mode".
	Options: OFF (default); Text - by code ; Text - by Key ; Clock - by Code ; Clock - by Key .
	Note: 1. To comply with EN requirements, "refresh by code" must be selected. 2. For Fire and Emergency keys, the first key press will produce the status display and will also perform the Fire/Emergency function.

5.5.7 Configuring Jamming and Supervision (Missing device)

The following table provides you with a detailed description of each option and its Options. To select an option and change its setting (configuration) – refer to section 5.5.1.

Option	Configuration Instructions															
61:JAM DETECT	Define whether jamming (continuous interfering transmissions on the radio network) will be detected and reported or not. If any of the jam detection options is selected, the system will not allow arming under jamming conditions. The WP8010/WP8030 provides several jam detect and reporting options to comply with the following standards: Note: Jamming is identified by the message "system jammed" displayed on the control panel.															
	<table border="1"> <thead> <tr> <th>Option</th> <th>Standard</th> <th>Detection and Reporting occurs when:</th> </tr> </thead> <tbody> <tr> <td>UL 20/20</td> <td>USA</td> <td>There is continuous 20 seconds of jamming</td> </tr> <tr> <td>EN 30/60</td> <td>Europe</td> <td>There is an accumulated 30 seconds of jamming within 60 sec.</td> </tr> <tr> <td>Class 6 (30/60)</td> <td>British Standard</td> <td>Like EN (30/60) but the event will be reported only if the jamming duration exceeds 5 minutes.</td> </tr> <tr> <td>disabled</td> <td>(default)</td> <td>No jamming detection and reporting.</td> </tr> </tbody> </table>	Option	Standard	Detection and Reporting occurs when:	UL 20/20	USA	There is continuous 20 seconds of jamming	EN 30/60	Europe	There is an accumulated 30 seconds of jamming within 60 sec.	Class 6 (30/60)	British Standard	Like EN (30/60) but the event will be reported only if the jamming duration exceeds 5 minutes.	disabled	(default)	No jamming detection and reporting.
	Option	Standard	Detection and Reporting occurs when:													
	UL 20/20	USA	There is continuous 20 seconds of jamming													
	EN 30/60	Europe	There is an accumulated 30 seconds of jamming within 60 sec.													
Class 6 (30/60)	British Standard	Like EN (30/60) but the event will be reported only if the jamming duration exceeds 5 minutes.														
disabled	(default)	No jamming detection and reporting.														
Notes: To comply with UL requirements, "UL 20/20" must be selected. To comply with EN requirements, "EN 30/60" must be selected. To comply with UK Class-6 requirements, "class 6 (30/60)" must be selected.																
62:MISSING REPRT	Define the time window for reception of supervision (keep alive) signals from the various wireless peripheral devices. If any device does not report at least once within the selected time window, a "MISSING" alert is initiated.															
	Options: after 1/2/4/8/12 (default) hour(s) ; and disabled .															
	Notes: 1. To comply with EN requirements, 1 hour or 2 hours must be selected. 2. For UL installations, set to "4 hours" or less. 3. For UL/ULC Residential Fire and Burglary Installations , the wireless supervision window shall be enabled. It shall be set to 4 hours or less for Fire Installations and it shall be set to 24h for Burglary Installations only.															

63:NOT READY	Define that in case of a supervision problem (i.e. a device is "missing" - see "62: MISSING REPR") whether the system will continue to operate as normal or the system status will become "Not Ready" (upon missing) for as long as the "Missing" trouble exists. Options: normal (default) and if missing dev.
64:MISS/JAM ALRM	"EN/UL standards" require that if a supervision (missing) or jamming trouble occurs during AWAY arming, the siren will sound and the event will be reported as a tamper event. Define whether the system will behave according to EN standard or as normal (default). Note: To comply with EN requirements "EN standard" must be selected.
65:SMOK FAST MIS	Determine that If the smoke detector does not report at least once within a time window of 200 seconds, a "MISSING" alert is initiated. Options: Disabled (default) and Enabled .

5.5.8 Configuring Miscellaneous Features

The following table provides you with a detailed description of each option and its configuration settings. To select an option and change its configuration – refer to section 5.5.1.

Option	Configuration Instructions
75:CODE VERSION¹ Applicable in UK only	Define the WP8010/WP8030 code version (default "000") which needs to be synchronized with the monitoring station when the anti-code reset function is enabled (see menu 39). This allows the monitoring station personnel to provide the user, by telephone, the proper reset code after the user has stated the Quote code. Enter the code version (3 digits) 000 to 255.
91:USER PERMIT	User Permission enables you to determine whether access to the INSTALLER MODE requires the user's permission or not. If you select enabled , the installer will be able to access the system only through the user menu after the user code has been entered (see section 5.2). Options: disable (default) or enable (default in UK). Note: To comply with EN requirements, "Enable" must be selected.
92:BATTERY TYPE²	Define which type of battery pack is used for the system to supply proper charge current. Options: 7.2V NiMH (default) or 9.6V NiMH (default in UK).
93:SOAK PERIOD³	Define the period of time for the Soak Test. Options: Disable (default), 7 days , 14 days or 21 days . Notes: 1. If set to one of the above pre-defined period of times, to be operational Soak Test mode must also be set to " Enable Test " from the "02:ZONES/DEVICES" menu (see Section 5.4.6). 2. If a change is made to the period of time of the Soak Test while the zone is currently being tested, this will restart the Soak Test. 3. The start of the Soak Test period is defined in the factory from 9 AM (09:00).

¹ Code Version is not applicable for UL installations

² Refers to WP8030 only

³ Soak Test is not applicable for UL installations

3. WP8010 INSTALLATION

5.6 Communication

5.6.1 General Guidance – "Communication" Flow-Chart & Menu Options

The COMMUNICATION menu enables you to configure and customize the communication and reporting of alarm, troubles and other system events for monitoring companies or private users according to your local requirements and personal preferences. WP8010/WP8030 offers a variety of communication means including telephone PSTN landline, Cellular GSM, GPRS, EMAIL, MMS or SMS and IP via broadband internet connection.











Notes:

1. GPRS cannot be enabled in UL Listed product.
2. SMS is a supplementary feature.

The "04.COMMUNICATION" menu contains several sub-menu options, each covering a group of configurable features and parameters related to the communication and reporting as follows (see detailed list in Step 3 of the chart below):

Option	Description of Option Features and Parameters	Section
1:PSTN TEL LINE	Contains configurable features and parameters related to the PSTN telephone line to which the WP8010/WP8030 is connected.	5.6.2
2:GSM/GPRS/SMS	Contains configurable features and parameters related to the Cellular connection of the WP8010/WP8030 system.	5.6.3
3:C.S. REPORTING	Contains configurable features and parameters related to Reporting of event messages to Monitoring Stations via telephone, cellular or IP broadband communication.	5.6.4
4:PRIVATE REPORT	Contains configurable features and parameters related to Reporting event messages to Private Users via email, telephone, MMS or SMS.	5.6.5
5:MOTION CAMERA	Contains configurable features and parameters related to Motion Cameras for Video Alarm Verification and forwarding of image clips to the Monitoring Station and other remote subscribers via e-mail and/or MMS network.	5.6.6
6:UP/DOWNLOAD	Contains configurable connection information, access permission and security codes related to the Upload/Download procedures via PSTN or GPRS.	5.6.7
7:BROADBAND ^{1, 2}	Contains DHCP Client settings, enables to enter LAN parameters and reset broadband module/settings.	5.6.8

To enter the "04.COMMUNICATION" menu and to select and configure an option, proceed as follows:

Step 1	Step 2	Step 3	Step 4
Select "COMMUNICATION"	Select Communication Sub-menu option	Select the "Communication" Parameter you wish to configure	
			
INSTALLER MODE ↓			See
04.COMMUNICATION 	1:PSTN TEL LINE  ↓	AREA CODE SKIP LINE PREFIX DIAL METHOD	 5.6.2
	2:GSM/GPRS/SMS  ↓	GPRS REPORT GSM REPORT SMS REPORT GPRS APN GPRS USERNAME SIM PIN CODE	GPRS PASSWORD NETWORK ROAMING GPRS ALWAYS ON GSM KEEP ALIVE TRANS. PROTOCOL  5.6.3
	3:C.S. REPORTING  ↓ <small>(*) These options are available only to the "Master Installer"</small>	01:REPORT EVENTS * 02:1st RPRT CHAN 03:2nd RPRT CHAN 04:3rd RPRT CHAN 05:DUAL REPORT 11:RCVR1 ACCOUNT * 12:RCVR2 ACCOUNT * 16:PSTN/GSM RCV1 * 17:PSTN/GSM RCV2 *	46:PSTN RETRIES  47:GSM RETRIES 48:BB IP RETRIES³ 51:TEL AUTO TEST 52:AUTO-TST TIME 53:COM.FAIL RPRT →PSTN FAIL →GSM/GPRS FAIL 61:RPRT CNF ALRM 5.6.4

¹ Broadband is not applicable for UL installations

² The name of the product is PowerLink3 IP Communicator

³ BB IP Retries is not relevant for UL installations

Step 1	Step 2	Step 3	Step 4	
Select "COMMUNICATION"	Select Communication Sub-menu option	Select the "Communication" Parameter you wish to configure		
	<p>4:PRIVATE REPORT </p> <p>↓</p>	<p>21:IP RCVR 1 * 22:IP RCVR 2 * 26:SMS RCVR 1 * 27:SMS RCVR 2 * 41:PSTN FORMAT *</p> <p>VOICE REPORT</p> <p>→REPORTED EVENTS →1st Private tel# →2nd Private tel# →3rd Private tel# →4th Private tel# →Redial attempts →Voice<->private →Tel. acknowledge</p> <p>EMAIL BY SERVER</p> <p>→1st E-MAIL →2nd E-MAIL →3rd E-MAIL →4th E-MAIL</p>	<p>62:RECENT CLOSE * 63:ZONE RESTORE 64:SYST.INACTIVE 65:TWO WAY VOICE 66:24H ZONE RPRT</p> <p>SMS REPORT </p> <p>→REPORTED EVENTS →1st SMS tel# →2nd SMS tel# →3rd SMS tel# →4th SMS tel#</p> <p>SMS/MMS BY SRVR</p> <p>→1st SMS/MMS →2nd SMS/MMS →3rd SMS/MMS →4th SMS/MMS</p>	See
	<p>5:MOTION CAMERA </p> <p>↓</p>	<p>VIEW ON DEMAND VIEW TIME WINDOW VIEW OTHER ALARM</p>		5.6.5 See also User's Guide Chap. 6 Section B.12
	<p>6:UP/DOWNLOAD </p> <p>↓</p>	<p>PSTN UP/DOWNLOAD</p> <p>→Remote access →Mast. UL/DL code →Inst. UL/DL code →UL/DL Modes</p>	<p>GPRS UP/DOWNLOAD </p> <p>→Panel SIM Tel. # →1st caller ID# →2nd caller ID#</p>	5.6.6 5.6.7
	<p>7:BROADBAND^{1, 2} </p>	<p>DHCP Client MANUAL IP →IP ADDRESS →SUBNET MASK →DEFAULT GW</p>	<p>RESET MODULE </p>	5.6.8

5.6.2 Configuring PSTN (landline phone) Connection

Note: When cellular and Plink modules are both installed and primary and secondary reporting is defined via cellular and Plink networks, the PSTN can communicate only to the private phones.

The WP8010/WP8030 panels include a telephone dialer for reporting to Monitoring Stations using several optional Alarm Formats (see section 5.6.4 option 41) and to Private Telephones (see section 5.6.5 "VOICE REPORT"). Here you configure necessary parameters related to the PSTN telephone line to which the WP8010/WP8030 is connected.



Enter "1:PSTN TEL LINE", select the menu you wish to configure (see guidance above and in section 5.6.1), then refer to the table below.

Option	Configuration Instructions
AREA CODE SKIP	In some older PSTN networks, it may not be possible to dial from the control panel to other PSTN telephone numbers (such as monitoring stations or private phones), if the dialed number contains an area code which is identical to the area code of the panel (i.e. both the panel and

¹ Broadband is not applicable for UL installations
² The name of the product is PowerLink3 IP Communicator

3. WP8010 INSTALLATION

the other numbers are in the same PSTN area code).

If you encounter the same problem with the PSTN network the panel is connected to, you must enter here the area code of the PSTN telephone line to which the panel is connected (up to 4 digits) so that when dialing to other PSTN phone numbers programmed with the same area code, the WP8010/WP8030 will skip the area code from the dialed number.

LINE PREFIX Enter the prefix digit (if necessary) for the system to access an outside telephone line.

DIAL METHOD Define the dialing method used by the PSTN dialer of the WP8010/WP8030 control panel.

Options: **pulse** and **tone (dtmf)** (default).

5.6.3 Configuring GSM-GPRS (IP) - SMS Cellular Connection

The GSM/GPRS module is capable of communicating with the Monitoring station receiver by GPRS, GSM Voice (analog) or SMS Channels.

Each of the channels can be separately enabled or disabled to allow or prohibit the module from using it for the event reporting. If all channels are enabled, the GSM/GPRS module will always try GPRS first. If fails, it will try GSM voice. If fails, it will try any other possible method (PSTN Broadband) and only then it will try SMS. Disabling any of the GSM channels will cause the module to use a different sequence than the one described above.

04:COMMUNICATION   ...  2:GSM/GPRS/SMS   ...  MENU you wish 

Enter "2:GSM/GPRS/SMS", select the menu you wish to configure (see guidance above and in section 5.6.1), then refer to the table below which provides you with detailed explanations and configuration instructions for each option.

Option	Configuration Instructions
GPRS REPORT	Define whether the system will report events to the Monitoring Stations' PowerManage receivers via the GPRS (IP) Channel. For further information, see section 5.6.4 options 21 & 22. Options: disable (default); enable . <i>Note: This feature cannot be enabled in UL Listed product.</i>
GSM REPORT	Define whether the system will report events to the Monitoring Stations' Alarm Format receivers via the GSM Voice (analog) Channel. For further information, see section 5.6.4 option 41. Options: disable (default); enable .
SMS REPORT	Define whether the system will report events to the Monitoring Stations' SMS receivers via the SMS Channel. For further information, see section 5.6.4 options 26 & 27. Options: disable (default); enable .
GPRS APN	Enter the name of the APN Access Point used for the internet settings for the GPRS (up to 40 digits string). <i>Note: To enter the APN Access Point, use the "String Editor" in section 5.8.1.</i>
GPRS USERNAME	Enter the Username of the APN used for GPRS communications (up to 30 digits string). <i>Note: To enter the Username, use the "String Editor" in section 5.8.1.</i>
SIM PIN CODE	Enter the PIN code of the SIM card installed in the GSM module (up to 8 numerical digits). <i>Note: To enter the numerical PIN code, use the numerical keyboard.</i>
GPRS PASSWORD	Enter the Password of the APN used for GPRS communications (up to 16 digits string). <i>Note: To enter the Password, use the "String Editor" in section 5.8.1.</i>
NETWORK ROAMING	You can force the SIM card to use only its "Home Network" and disable it from roaming to other networks in case the Home Network cannot be found. Options: roam disable ; roam enable (default).

GPRS ALWAYS ON	Define whether the control panel will stay continuously connected " enabled ", via GPRS communication, or disconnect " disabled " (default), after each report session. Note: For UL installations, set to "enabled".
GSM KEEP ALIVE	Some GSM Service providers tend to disconnect the GSM connection if the user has not initiated any outgoing telephone calls during the last 28 days. To prevent from disconnecting the GSM connection, you can configure the system to generate a " keep alive " GSM call every 28 days sending a test message either to the first SMS number (if exists) or alternatively first private telephone number. Options: Disable (default) or Every 28 days .
TRANS. PROTOCOL	Select the IP protocol used to transfer data over the internet/GPRS. Options: TCP (default); or UDP .

5.6.4 Configuring Events Reporting to Monitoring Stations

The WP8010/WP8030 control panel is designed to report alarm, alerts, troubles and other events and messages to two Monitoring Stations C.S.1 and C.S.2 via PSTN telephone line, Cellular i.e. GSM voice (analog), GPRS (IP) & SMS or Broadband IP communications channels. In this section you configure and define all parameters and features required for the reporting of the event messages to Monitoring Stations such as:

- The events reported to each of the two Monitoring Stations C.S.1 and C.S.2 and corresponding backups.
- The communication means (channel) used for the reporting and the backup means (channel) in case of failure.
- The customer's (subscriber) account number(s) to be reported to each monitoring station.
- The telephone numbers, IP addresses and SMS numbers and reporting formats of the corresponding alarm receivers at the two Monitoring Stations C.S.1 and C.S.2 and the number of reporting retry attempts in case of failure to report.
- The communication Auto Tests and communication Fail reports.
- The reporting of certain system function events such as "Confirmed Alarm", "Recent Close", "Zone Restore" and "System Not-Used".

Notes: The notification of events to other 3rd party applications (SMS/IP/personal phones) is a supplementary feature that has not been investigated by UL and is not used in UL listed installations.



Enter "**3:C.S.REPORTING**", select the menu you wish to configure (see guidance above and in section 5.6.1), then refer to the table below which provides you with detailed explanations and configuration instructions for each option.

Option	Configuration Instructions
01:REPORT EVENTS	Define which events (i.e. Alarms (alm) ; Open/close (o/c) ; Alerts (alrt) ; All events (all) ; Maintenance and Troubles) will be reported to the Monitoring Stations. The minus (-) symbol means "less/except" e.g. all(-alrt)*alrt means all events except alerts . The asterisk (*) is a separator between events reported to Monitoring Station 1 (C.S.1) and events reported to Monitoring Station 2 (C.S.2). For detailed and more complete explanation see the " Event Reporting Chart " at the end of this section. Options: all-o/c* backup (default) all-o/c*o/c disable report all *all all(-alrt)*alrt all *backup all-o/c*all-o/c alm*all(-alm)
Note: Alarm events (<i>alm</i>) have highest priority and Alert events (<i>alrt</i>) have lowest priority.	

02:1st RPRT CHAN	If the system is equipped also with Cellular communicators, you <u>must</u> define which of the communicating channels (i.e. Cellular, Broadband or PSTN) the system will use as the main channel (i.e. 1 st priority) for reporting event messages to Monitoring Stations, and if the main channel fails, which channels will be used for the 2 nd and 3 rd reporting priorities. Enter the "1 st RPRT CHAN"; option and define which of the communication channels the system will use as the main reporting channel. To define also backup reporting channels, enter the "2nd RPRT CHAN" and "3rd RPRT CHAN" options and define them as well. Options: disable (default); cellular ; broadband and PSTN .
03:2nd RPRT CHAN	
04:3rd RPRT CHAN	
Important: If the selected main reporting channel fails, the system will use the other communication channel to report event messages to Monitoring Stations. If none is selected, the reporting to monitoring stations will be disabled.	

3. WP8010 INSTALLATION

Option	Configuration Instructions
	Note: When Cellular channel is selected, the order of priority will be GPRS (IP) channel first, then GSM voice channel and lastly SMS channel, provided that these channels have been enabled in section 5.6.3.

05:DUAL REPORT	Define whether or not to report events using PSTN and broadband, PSTN and cellular or broadband and cellular communication channels. Options: disable (default); PSTN & broadband ; PSTN & cellular ; broadband & cell .
-----------------------	---

11:RCVR1 ACCOUNT 12:RCVR2 ACCOUNT	Enter the respective 1 st Account (subscriber) number (11:RCVR 1 ACCOUNT) that will identify your specific alarm system to the 1 st Monitoring Station (designated as RCVR1 or RCV1) and a 2 nd Account (subscriber) number (12:RCVR 2 ACCOUNT) that will identify the system to the 2 nd Monitoring Station (designated as RCVR2 or RCV2). Each of the Account numbers consists of 6 hexadecimal digits.
--	---

To enter Hexadecimal digits, use the following table:

Master Installer only	Entering Hexadecimal Digits							
	Digit	0....9	A	B	C	D	E	F
	Keying	0....9	[#]→[0]	[#]→[1]	[#]→[2]	[#]→[3]	[#]→[4]	[#]→[5]

16:PSTN/GSM RCV1 17:PSTN/GSM RCV2	The WP8010/WP8030 can be programmed to report the event messages defined in the Report Events option (option 01) to two Alarm Format Receivers via PSTN telephone line and/or GSM analog voice channel (if equipped with GSM module), using standard PSTN alarm formats (i.e. SIA and/or Contact-ID approved by UL, and Scancom not for UL). The reporting format is defined in the "PSTN Report Format" option (option 41).
--	--

Master Installer only

Enter the two respective telephone numbers (**including area code** – maximum 16 digits) of the Alarm Format Receiver 1 located at the 1st Monitoring Station (16: PSTN/GSM RCV1) and alarm format Receiver 2 located at the 2nd Monitoring Station (17: PSTN/GSM RCV2).

Note: If any of the phone numbers programmed herein contain an **area code** identical to the area code of the PSTN telephone line to which the system is connected, you should refer to the "**AREA CODE**" option in section 5.6.2. and act as instructed there.

Digit	Keying	Digit Significance
A	[#]→[0]	The dialer waits 10 seconds or waits for dial tone, whichever comes first and then dials. Applicable <u>only</u> at the 1 st digit.
D	[#]→[3]	The dialer waits 5 seconds for dial tone and goes on hook if none is received. Applicable <u>only</u> at the 1 st digit.
E	[#]→[4]	The dialer waits 5 seconds. Applicable only in the middle of the number.
To move the cursor and clear digits , use the " String Editor's " keys as described in the table in section 5.8.1.		

21:IP RCVR 1 22:IP RCVR 2	If equipped with GSM or Broadband/PowerLink modules, the WP8010/WP8030 can be programmed to report the event messages defined in Report Events option (option 01) to two IP Receivers, DSC PowerManage model. IP reporting can be performed via GPRS (IP) channel using SIA IP format or via Broadband IP channel using SIA IP or DSC PowerNet format.
--	--

Master Installer only

Enter the two IP addresses (000.000.000.000) of the IP Receiver 1 located at the 1st Monitoring Station (21:IP RCVR 1) and IP Receiver 2 located at the 2nd Monitoring Station (22:IP RCVR 2).

26:SMS RCVR 1 27:SMS RCVR 2	If equipped with GSM module, the WP8010/WP8030 can be programmed to report the event messages defined in Report Events option (option 01) to two SMS Receivers via the GSM SMS channel using a special SMS text format. For further details concerning the SMS text format please contact DSC.
--	--

Master Installer only

Enter the two telephone numbers (including area code – maximum 16 digits) of the SMS Receiver 1 located at the 1st Monitoring Station (26:SMS RCVR 1) and SMS Receiver 2 located at the 2nd Monitoring Station (27:SMS RCVR 2).

Notes:

- To enter the international prefix (+) at the 1st digit – key-in [#]→[1].
- SMS is not sent to UL/ULC listed Monitoring Station receivers. This is a supplementary feature of the WP8010/WP8030.

Option	Configuration Instructions
41:PSTN FORMAT Master Installer only	<p>The WP8010/WP8030 can be programmed to report the event messages defined in Report Events option (option 01) to two Alarm Format Receivers (see options 16 & 17) via PSTN telephone line and/or GSM analog voice channel (if equipped with GSM module) using standard PSTN alarm formats (i.e. SIA, Contact-ID and Scancom).</p> <p>Select which of the reporting formats the system will use to report the events to the two Alarm Format Receivers PSTN/GSM RCVR 1 and PSTN/GSM RCVR 2. The Event Codes used for the reporting in each of the available formats are specified in APPENDIX D. Event Codes. Make sure that the receivers used by the Monitoring Stations are of the compatible models listed below and that the receiver used can receive the format you select.</p> <p><u>Compatible Alarm Format Receivers:</u> <i>UL/ULC listed receivers: SG-System I, SG-System III, SG-System IV.</i></p> <p>Options: SIA (default); Scancom; SIA text and contact ID.</p> <p>Note: For UL installations, the communication formats used are SIA and Contact ID and the compatible receivers are the ones mentioned above.</p>
46:PSTN RETRIES	<p>Define the number of times the system will retry to report to the Monitoring Station in case of failure to report via the PSTN telephone line connection.</p> <p>Options: 2 attempts; 4 attempts (default); 8 attempts; 12 attempts and 16 attempts.</p> <p>Note: For UL Listed product, set to "8 attempts".</p>
47:GSM RETRIES	<p>Define the number of times the system will retry to report to the Monitoring Station in case of failure to report via the cellular connection - GPRS (IP), GSM and SMS.</p> <p>Options: 2 attempts; 4 attempts (default); 8 attempts; 12 attempts and 16 attempts.</p> <p>Note: For UL Listed product, set to "8 attempts".</p>
48:BB IP RETRIES¹	<p>Define the number of times the system will retry to report to the Monitoring Station in case of failure to report via the Broadband Module connection.</p> <p>Options: 2 attempts; 4 attempts (default); 8 attempts; 12 attempts and 16 attempts.</p>
51:TEL AUTO TEST	<p>To verify a proper communication channel, the WP8010/WP8030 can be configured to send a test event to the Monitoring Station via PSTN periodically. You can set the interval between the consecutive test events or disable the automatic sending of this event entirely. If the interval is set for every one day or more then the exact hour of reporting can be selected with option 52.</p> <p>Options: test OFF (default); every 1/2/5/7/14/30 day(s); and every 5 hours.</p> <p>Note: For UL Listed product, set to "every 1 day".</p>
52:AUTO TST TIME	<p>Enter the exact time (auto test time) during the day at which the Auto Test message (if enabled in option 51) will be sent to the Monitoring Station.</p> <p>Note: If the AM/PM format is used, you can set the "AM" digit with the * ↻ button and the "PM" digit with the 🏠 # button.</p>
53:COM.FAIL RPRT →PSTN FAIL →GSM/GPRS FAIL  (Return)	<p>Determine whether a failure in any of the system communication channels i.e. PSTN or GSM/GPRS will be reported or not and the time delay between detection of the failure and reporting of the failure event to the Monitoring Station. A trouble event (i.e. "tel line fail" or "GSM line fail") will be respectively stored in the event log.</p> <p>Options "PSTN FAIL": immediat report (default); after 5/30/60/180 min; and do not report.</p> <p>Options "GSM/GPRS FAIL": after 2/5/15/30 min and do not report (default).</p>
61:RPRT CNF ALRM	<p>Define whether the system will report whenever 2 or more events (confirmed alarm) occur during a specific period or enable the report and bypass the detector.</p> <p>Options: rprt disabled (default), rprt ena+bypass and rprt enabled</p> <p>Note: In some WP8010/WP8030 variants, this menu is displayed in the Operation Mode only.</p>

¹ BB IP Retries is not relevant for UL installations

3. WP8010 INSTALLATION

Option	Configuration Instructions
62:RECENT CLOSE 63:ZONE RESTORE 64:SYST.INACTIVE 65:TWO WAY VOICE¹ →Send 2wv code →Voice <- -> C.S. →Ringback time →Ambient level  (Return) Master Installer only for Send 2wv code / Voice <-> C.S. / Ringback time Send 2wv code Voice <- -> C.S Ringback time Ambient level	<p>False alarms may occur if users do not exit the premises within the exit delay period, resulting in a false alarm a short time later. In such cases, inform the Monitoring Station that the alarm occurred shortly after the system was armed (this event is known as "Recent Close"). The report enabled option sends a "recent closing" report to the Monitoring Station if an alarm occurs within 2 minutes from the end of the exit delay.</p> <p>Options: report disabled (default) and report enabled</p> <p>Notes:</p> <ol style="list-style-type: none"> CP-01 was tested and certified by ETL/Intertek. CP-01 features not to be enabled in UL Listed product. <hr/> <p>Some Monitoring Stations require that following an alarm event from a specific zone, the system will also report when the alarming zone has restored to normal.</p> <p>Options: report enabled (default) and report disabled</p> <hr/> <p>The WP8010/WP8030 can report a "System Inactive" event message (CID event 654) to the Monitoring Station if the system is not used (i.e. armed) during a predefined time period.</p> <p>Options: report disabled (default); after 7/14/30/90 days.</p> <hr/> <p>You can configure the two way voice channel settings of the control panel¹, as follows:</p> <p>Send 2 WV Code: Define whether the system will send two-way voice code to the Monitoring Station (to turn the Monitoring Station from data communication to voice communication state) by using pre-selected SIA or Contact-ID communication format only.</p> <p>Voice <-> C.S.: Select the timeout for 2-way voice communication with Monitoring Stations, or enable the Monitoring Station to ring back for 2-way voice function. This option is applicable only after reporting an event to the Monitoring Station for listening and speaking.</p> <p>Ringback Time: Define the period during which the Monitoring Station can establish 2-way voice communication with the control panel¹ (after 1 ring), if:</p> <ol style="list-style-type: none"> Alarm type message was received by Monitoring Station. Ring Back function was selected (see "Voice <-> C.S." sub menu above). <p>Ambient Level: Select the ambient noise level of the installation. If it is a relatively noisy environment, set it to High (default setting). If it is a very quiet environment, set to Low.</p> <p>Note: Two-way voice not to be enabled on UL Listed product.</p> <p>Options: disable (default); and enable.</p> <p>Options: disable (default); timeout 10/45/60/90 s; timeout 2 m; and ringback.</p> <p>Note: If "ring back" is selected, you should select "disable report" for private telephone (see Option "01:REPORT EVENTS"), otherwise the Monitoring Station will establish communication with the control panel¹ (after an event occurrence) in the normal manner (and not after one ring).</p> <p>Options: 1 (default)/3/5/10 minute(s).</p> <p>Options: low (default); and high.</p> <hr/> <p>Define whether 24 hour (silent and audible) zones will function as normal 24 hour zones or as panic zones.</p> <p>Options: audibl as panic; silent as panic; both as panic; and both burglary (default).</p>
66:24H ZONE RPRT Applicable in UK only	<p>Define whether 24 hour (silent and audible) zones will function as normal 24 hour zones or as panic zones.</p> <p>Options: audibl as panic; silent as panic; both as panic; and both burglary (default).</p>

¹ Refers to WP8030 with voice option only

Event Reporting Chart

To simplify the configuration of reporting system events to Monitoring Stations, the event messages are divided into 4 Event Groups as described in the following table below: Due to lack of space in the display, the following abbreviations are used **alm**, **alrt**, **o/c** and **all** (i.e. all events).

Event Group	Abbr.	Events Messages Reported
Alarms	alm	Fire, CO, Burglary, Panic, Tamper
Open/close	o/c	Arming AWAY, Arming HOME, Disarming
Alerts	alrt	No-activity, Emergency, Latchkey
Trouble	-	All other Trouble events not indicated above, e.g. Low battery, AC failure, Missing, Jamming, Communication Fail etc.

Note: "Alarms" group has the highest priority and "Alerts" group has the lowest priority.

The WP8010/WP8030 allows you also to select which event groups will be reported to each of the two Monitoring Stations. The table below describes the available reporting options. The minus (-) symbol means "but/less/except" e.g. **all(-alrt)** means **all** events except **alrts**. The asterisk (*) is a separator between event messages reported to **Monitoring Station 1** (C.S.1) and event messages reported to **Monitoring Station 2** (C.S.2).

Available Reporting Options	Events Reported to C.S. 1	Events reported to C.S. 2
"all * backup"	All	All, only if C.S.1 does not respond
"all-o/c * backup"	All but open/close	All but open/close, only if C.S. 1 does not respond
"all * all"	All	All
"all-o/c * all-o/c "	All but open/close	All but open/close
"all-o/c * o/c "	All but open/close	Open/close
"all(-alrt) * alrt"	All but alerts	Alerts
"alm * all(-alm)"	Alarms	All but alarms
"disable report"	None	None

Note: "all" means that all 5 Groups are reported including Trouble messages - sensor / system low battery, sensor inactivity, power failure, jamming, communication failure etc.

5.6.5 Configuring Events Reporting to Private Users

The WP8010/WP8030 system can be programmed to send various event notifications such as alarm, arming or trouble events, to 4 Private telephone subscribers using audible signals and if a GSM option is installed, the system can send the messages also to 4 emails, MMS and SMS telephone numbers via the server. These reports can be programmed either instead of or in addition to the reports transmitted to the monitoring company. In this section you configure:

- The specific events you wish the system to report.
- The 1st, 2nd, 3rd, and 4th Private telephone and SMS numbers of the private subscribers.
- Event notification messages to be sent to 1st, 2nd, 3rd, and 4th private emails and private MMS and SMS telephone numbers via the server.
- The number of redial attempts, two-way voice communication¹ and your preferred acknowledge method i.e. whether a single acknowledge signal will stop the reporting process or an acknowledge signal from each telephone will be required before the reported event is considered reported.

To select and configure an option follow the instructions below. Additional guidance is provided in section 5.6.1.

04:COMMUNICATION   ...  4:PRIVATE REPORT   ...  MENU you wish 

The "4:PRIVATE REPORT" menus and sub-menus configuration is shown in the table in section 5.6.1. For a detailed description of the menu options, refer to the User's Guide Chapter 6, section B.12.

5.6.6 Configuring Motion Cameras for Visual Alarm Verification

If equipped with a GSM/GPRS module, the WP8010/WP8030 can communicate to Monitoring Stations (equipped with DSC PowerManage server) via the GPRS network, also with image clips captured by Motion Cameras (models PG9934, Next-PG9904 and PG9944). The Monitoring Station can use the video clips for verification of Burglary alarms detected by the Motion Cameras. The system can be configured to capture image clips also upon occurrence of Non-Burglary alarms (i.e. Fire, Duress, Emergency and Panic). The server can then forward the images to the management computer of the monitoring station or to 4 remote computers via e-mail and/or 4 mobile phones by MMS images. In addition, the monitoring station can log into the PowerManage server and request the system to provide image clips

¹ Refers to WP8030 with voice option only

3. WP8010 INSTALLATION

"On Demand" and to forward them as defined in the PowerManage application. To protect customers' privacy, the WP8010/WP8030 can be customized to enable the "On Demand View" only during specific system modes (i.e. Disarm, Home and Away) and also to a specific time window following an alarm event. In this section you can program the 4 e-mail addresses and mobile phone numbers to which the images will be forwarded and to configure the parameters of the "On Demand View".

Note: Motion cameras are not to be enabled in UL Listed products.

04:COMMUNICATION ... 5:MOTION CAMERAS ... MENU you wish

Enter "5:MOTION CAMERAS", select the menu you wish to configure (see guidance above and in section 5.6.1), then refer to the table below which provides you with detailed configuration instructions.

Option	Configuration Instructions
VIEW ON DEMAND	By enabling the "On Demand View", you can determine during which arming modes (system states) the "On Demand View" will be permitted. In the next option "VIEW TIME WINDOW" you can determine when, during the permitted arming modes, the "On Demand View" will be enabled. Options: disabled (default); in all modes ; in AWAY only ; in HOME only ; in HOME & AWAY; DISARM & AWAY ; DISARM & HOME ; and in DISARM only .
VIEW TIME WINDOW "VIEW TIME WINDOW" menu appears only if an option other than "Disabled" is selected in "VIEW ON DEMAND"	If the "On Demand View" is enabled in the previous option, you can further determine whether the "On Demand View" will be possible at any time during the selected arming modes (i.e. "Always") or restricted only to a specific limited time window that follows an alarm event. Options: Always (default); Alarm + 5 min. ; Alarm + 15 min. ; Alarm + 1 hour
VIEW OTHER ALARM	Define whether the system will capture and forward image clips also upon occurrence of Non-Burglary alarms (i.e. Fire, Duress, Emergency and panic). Options: Enable (default); Disable .

5.6.7 Configuring Upload / Download Remote Programming Access Permission

Using a PC, the WP8010/WP8030 can be configured (by upload/download) either locally or from remote via PSTN telephone line or GPRS cellular communication.

Note: For UL installations, do not enable Remote Programming via GPRS.

Local programming can be performed by directly connecting the computer to the panel's serial port using the Remote Programmer PC Software.

Remote programming via PSTN can be performed by using a modem and the same software. The modem dials to the control panel and establishes a connection via PSTN using an agreed process. When connection is established, the installer or Master installer can access the panel using the UL/DL access codes programmed in the "PSTN UP/DOWNLOAD" menu – see table below. For further information refer to the "WP8010/WP8030 Remote Programmer Software User's Guide".

Remote programming via GPRS is performed using a DSC PowerManage server and related Remote Programmer PC software. The PowerManage server calls from a cellular modem to the Panel's SIM card number. The panel checks the caller ID and if identical with any of the two callers ID 1 or 2 programmed in the "GPRS UP/DOWNLOAD" menu (see table below), the panel initiates a GPRS connection with the respective IP Receiver 1 or 2 (as configured in section 5.6.4 options 21 & 22). When connection is established, the monitoring company can perform the upload/download procedure via the established secured GPRS connection. For further information refer to the PowerManage User's Guide

In this section you can configure the access permissions (i.e. security codes and identification) and determine the functionality of the upload/download procedures via PSTN and GPRS channels.

04:COMMUNICATION ... 6:UP/DOWNLOAD ... MENU you wish

Enter "**6:UP/DOWNLOAD**", select the menu to configure (see guidance above and in section 5.6.1), then refer to the table below for configuration instructions.

Option	Configuration Instructions
PSTN UP/DOWNLOAD	<p>Configure the Upload/Download functionality via PSTN. The functionality is determined through a sub-menu of the "PSTN UP/DOWNLOAD" option as shown below.</p> <p><u>To program:</u></p> <p>Press OK to enter the "PSTN UP/DOWNLOAD" sub menu and then select and configure each of the sub-menu options as shown below. When done, press ↩ to return.</p>
→ Remote access	<p>Enable or disable the remote access to the system. If disabled, the system cannot be accessed remotely thereby inhibiting the Upload/Download and the Remote Control via PSTN or GSM analog communication channels (see Chapter 7 in the User's Guide).</p> <p>Options: enabled (default); disabled.</p>
→ Mast. UL/DL code	<p>Enter the 4-digit password (Master Installer download code) code that will allow the Master Installer to access the system remotely and upload/download data to the WP8010/WP8030 panel.</p> <p>Note: "0000" is not a valid code and must not be used.</p>
→ Inst. UL/DL code	<p>Enter the 4-digit password (Installer download code) code that will allow the Installer to access the system from remote and upload or download data into the WP8010/WP8030 panel.</p> <p>Notes:</p> <p>"0000" is not a valid code and must not be used.</p> <p>The installer can configure via UL/DL only the options he is authorized to configure from the control panel.</p>
→ UL/DL modes	<p>Define whether the downloading/uploading can be performed in Disarm mode (state) only or in all modes (i.e. Away, Home & Disarm).</p> <p>Options: in all modes (default) or in DISARM only.</p>
↩ (Return)	
GPRS UP/DOWNLOAD	<p>Configure the Upload/Download functionality via GPRS. The functionality is determined through a sub-menu of the "GPRS UP/DOWNLOAD" option as shown below.</p> <p><u>To program:</u></p> <p>Press OK to enter the "GPRS UP/DOWNLOAD" sub menu and then select and configure each of the sub-menu options as shown below. When done, press ↩ to return.</p>
→ Panel SIM Tel.#	<p>Enter the WP8010/WP8030 SIM card telephone number. The PowerManage server at the Monitoring Station sends an SMS message to this number for the panel to call back the PowerManage server via GPRS for initiating the uploading / downloading process.</p> <p>Enter the SIM card telephone number of the panel's GSM module.</p>
→ 1st caller ID#	<p>Enter the "Caller ID" (i.e. telephone number) from which Monitoring Station #1 (C.S.1) / Monitoring Station #2 (C.S.2) calls the control panel for initiating the Up/Download process. If the sender's Caller ID matches with the "1st caller ID#" / "2nd caller ID#", the WP8010/WP8030 will call back the PowerManage server using "IP RCVR 1" / "IP RCVR 2" address as configured in Section 5.6.4, options 21 and 22.</p> <p>Note: Caller ID#1/ID#2 must contain at least 6 digits otherwise the process will not work.</p>
→ 2nd caller ID#	
↩ (Return)	

3. WP8010 INSTALLATION

5.6.8 Broadband^{1, 2}

Note: If the Broadband Module is not registered to the WP8010/WP8030, the menu "7:BROADBAND" will not be displayed.

In this section you can configure how to obtain an IP address, enter LAN parameters and reset broadband module settings.

04:COMMUNICATION   ...  7:BROADBAND   ...  MENU you wish 

Enter "7:BROADBAND", select the menu to configure (see guidance above and in section 5.6.1), then refer to the table below for configuration instructions.

Option	Configuration Instructions
DHCP Client	Define whether to obtain an IP address automatically using a DHCP server or to enter an IP address manually. Options: disable ; enable (default).
MANUAL IP ³	Manually enter LAN parameters. Note: This menu will appear only if DHCP Client is disabled.
→IP ADDRESS	Enter the IP address of the Broadband Module
→SUBNET MASK	Enter the subnet mask used with the IP address.
→DEFAULT GW	Enter the default gateway of the Broadband Module. Note: If DHCP Client is set to Enable, the entries for IP ADDRESS, SUBNET MASK and DEFAULT GW will be ignored.
RESET MODULE	Determine whether to reset the broadband module (reboot) or to reset all broadband settings – does not reset Monitoring Station IP settings. (factory defin.).

5.7 PGM Output

5.7.1 General Guidance

The "05:OUTPUTS" menu enables you to select events/conditions under which the PGM (programmable) output will function and to select the internal siren or strobe light (that will be activated according to system programming).⁴

05:OUTPUS   ...  PGM OUTPUTS  ··· PGM DEVICE 01  ··· MENU you wish 

Enter "PGM DEVICE 01", select the menu you wish to configure (see guidance above and in section 5.2), and then refer to the table in section 5.7.3 for configuration instructions.

Note: PGM not to be enabled in UL Listed Product.

5.7.2 Open Collector States

The WP8010/WP8030 provides an open collector output (active low) for control:

ON state (pulled to ground) = 0

OFF state:

no pullup = float

with pullup to Vcc = 1

¹ Broadband is not applicable for UL installations

² The name of the product is PowerLink3 IP Communicator

³ This menu is displayed only when DHCP client is set to "disable".

⁴ In WP8010, this is always available. In WP8030, this is optional only when the expansion module is installed.

5.7.3 PGM Output Configuration

Define which factors, including any combination of factors, will determine the PGM output.

Option	Configuration Instructions
PGM: BY ARM AWAY PGM: BY ARM HOME PGM: BY DISARM	Determine to activate the PGM output upon arming Away / Home / Disarm . Options: disable (default); turn ON ; turn OFF ; activate PULSE .
PGM: BY MEMORY	Determine to activate the PGM output upon registration of an alarm in the memory. The output will restore to normal upon memory clearing. Options: disable (default); turn ON ; turn OFF ; activate PULSE . Note: <i>In Soak Test¹ mode and when BY MEMORY is enabled, the PGM will not be activated.</i>
PGM: BY DELAY	Determine to activate the PGM output during the Exit and Entry delays. Options: disable (default); turn ON ; turn OFF ; activate PULSE .
PGM: BY KEYFOB	Determine to activate the PGM output upon pressing the AUX (★) button of keyfob transmitters configured to activate the PGM output. For further details, refer to the configuration instructions of the AUX (★) button of the respective keyfobs' datasheets. Options: disable (default); turn ON ; turn OFF ; activate PULSE ; toggle
PGM: BY SENSOR → Zone A Z: __ → Zone B Z: __ → Zone C Z: __	Determine to activate the PGM output upon activation of any one of up to 3 sensors (zones) in the systems irrespective of whether the system is armed or disarmed. <u>To configure:</u> Press OK to enter the "PGM: BY SENSOR" sub menu and then select the Zone you wish to program, for example "Zone A". If the zone was configured before, the display shows the current zone number "(Z:xx)" and if not, the zone number will be blank ("Z: __"). To configure the zone number, press OK . Enter the Zone number (2 digits) you wish to activate the PGM output and press OK to confirm. To add another sensor, select any of the other two options ("Zone B" and "Zone C") and repeat the above process. When done press FA to return. Options: disabled (default); turn ON ; turn OFF ; activate PULSE ; toggle Note: <i>If you select toggle, the PGM output will be turned on upon event occurrence in any of these zones and will be turned off upon next event occurrence, alternately.</i>
PGM:BY LINE FAIL	Determine to activate the PGM output following failure of the PSTN line Options: by line fail NO (default); by line fail YES .
PGM:BY SIREN	Determine to activate the PGM output as an external wired siren. Options: disable (default) and ON&OFF by siren .
PGM:PULSE TIME	Determine the PGM output pulse time. This value is the same for all events (by ARM AWAY, by ARM HOME, by DISARM etc.) which were selected with "activate PULSE" option. Options: pu lse time 2s (default); pulse time 30s ; pulse time 2m ; pulse time 4m .

Note: PGM not to be enabled in UL Listed Product.

¹ Soak Test is not applicable for UL installations

3. WP8010 INSTALLATION

5.7.4 PGM-5 Connection

05:OUTPUTS **OK** >> ... >> EXTERNAL PGM **OK** PGM-5 OPTIONS **OK** ...

If a PGM-5 module has been connected, proceed to enable the operation of the module as follows:

Step 1	Step 2	Step 3	Step 4
Select "05:OUTPUTS" menu	Select "EXTERNAL PGM" menu	Press OK	Panel displays currently selected setting
05:OUTPUTS OK	EXTERNAL PGM OK	PGM-5 OPTIONS OK	Disabled ■
Step 5	Step 6		
Select whether to enable or disable the PGM-5			
Enabled OK	Enabled ■	to Step 3	

5.7.5 Entering Daytime Limits

05:OUTPUTS **OK** >> ... >> PGM OUTPUTS >> ... >> LOCKOUT TIME **OK** ...

Enter the "LOCKOUT TIME" menu and enter the daytime limits through which the PGM device will turn off, even when the associated sensors are triggered.

Step 1	Step 2	Step 3	Step 4	
Select "05:OUTPUTS" menu	Select "LOCKOUT TIME" menu	Press OK	Enter the time at which you wish the lockout state to begin	
05:OUTPUTS OK	LOCKOUT TIME OK	start- HH:MM OK	TIME <u>11:30</u> OK	
Step 5	Step 6	Step 7	Step 8	
Press >>	Press OK	Enter the time at which you wish the lockout state to end	Press ↑ to return to "LOCKOUT TIME" or ↓ to take you to "<OK> TO EXIT"	
start- HH:MM	stop- HH:MM OK	TIME <u>19:00</u> OK	stop- HH:	

5.8 Custom Names

5.8.1 Custom Zone Names

During the device enrollment process you also define the Location name where the device is installed. The location name is selected from a Location List of Custom names - see Section 5.4.2, Part B, for Location List and instructions. Define the custom location names according to your specific needs and use them during device enrollment.

To define the Custom Location names, follow the instructions below. Additional guidance is provided in section 5.2.

06:CUSTOM NAMES ... CUST.ZONES NAME

Enter "CUST.ZONES NAME" (see guidance above), then refer to the table below which provides you with detailed explanations and programming instructions to edit the desired custom location.

Note:

WP8010: All 31 custom names can be edited.

WP8030: The following custom names can be edited: Dining room, Garage door, Guest room, Master bath, Master Bdrm, Custom 1, Custom 2, Custom 3, Custom 4 and Custom 5.

Configuration Instructions

Enter the Custom Location names you wish to edit.

To edit:

Press to enter the "CUST. ZONES NAME" sub menu and then press again to select the Location # you wish to edit, for example "TEXT LOC. #01" – the display alternates with the current Custom name, for example, "Dining room". To change the name, at the blinking cursor, enter the Location name you wish and at the end, press to confirm. When done, press to return.

Note: To enter the Location name use the "String Editor" below.

IMPORTANT! The editing of a custom zone name automatically deletes the original text and recorded voice name. Make sure to record a new voice name via the RECORD ZONE NAME menu (see next section).

WP8010/WP8030 String Editor

Key	String Editor Functionality
	' ', '0'
	'1', ' ', '1'
	'a', 'A', 'b', 'B', 'c', 'C', '2'
	'd', 'D', 'e', 'E', 'f', 'F', '3'
	'g', 'G', 'h', 'H', 'i', 'I', '4'
	'j', 'J', 'k', 'K', 'l', 'L', '5'
	'm', 'M', 'n', 'N', 'o', 'O', '6'
	'p', 'P', 'q', 'Q', 'r', 'R', 's', 'S', '7'
	't', 'T', 'u', 'U', 'v', 'V', '8'
	'w', 'W', 'x', 'X', 'y', 'Y', 'z', 'Z', '9'
	Moves the digits cursor from left to right . Long press for fast movement.
	Moves the digits cursor from right to left . Long press for fast movement.
	Changes between lowercase letters (a,b,c...z), uppercase letters (A,B,C...Z) and numbers (1,2,3).
	Clears a single digit of the string by cursor.
	Clears all digits of the string to the left of cursor.
	Confirms and saves the edited string and reverts to previous menu.
	Exiting the edit screen and moves one level up to previous or top menu without saving the edit string.
	Exiting the edit screen and moves to the "<OK> TO EXIT" exit screen without saving the edit string.

3. WP8010 INSTALLATION

5.8.2 Record Speech¹

You can record short-duration speech messages for the house identity, user names and custom zone names.

For the recording procedure follow the instructions below. Additional details and guidance are provided in section 5.2.

06:CUSTOM NAMES ... RECORD HOUSE ID

Enter "RECORD SPEECH", select the menu you wish to perform (see guidance above), then refer to the tables below which provide you with detailed explanations for each option.

Option	Instructions
--------	--------------

RECORD HOUSE ID	You can record a message to be announced automatically when events are reported to private telephones.
------------------------	--

While in "06:CUSTOM NAMES", press ; the display now reads "RECORD HOUSE ID" and alternates with "REC-<2> PLAY-<5>" (this means, press the button to record and the button to play recording).

To initiate the recording procedure, press the button continuously to record your message; "RECORD A MESSAGE" appears momentarily and then changes to "TALK NOW■■■■■" (the square boxes slowly disappear, one by one, until the end of the recording time).

At the end of the recording process, the panel will display the following:

"RECORDING ENDED". Release the button.

Note: To check the recorded message, press the button and listen to the playback.

To advance to the next stage in the recording procedure; from the "RECORD HOUSE ID" menu, click ; the display now reads "RECORD USER NAME". Press to proceed.

Option	Instructions
--------	--------------

USER VOICE 23	You can record ten user names and assign them to users 23-32. In case of event, the relevant user name will be added to the message that will be reported via the telephone.
----------------------	--

Record user names for 23-32; the procedure is identical to the "RECORD HOUSE ID" recording procedure described above. Click to navigate between user name numbers.

To advance to the next stage in the recording procedure; from the "RECORD USER NAME" menu, click ; the display now reads "RECORD ZONE NAME". Press to proceed.

Instructions

You can record zone names (for example, Garage door, Guest room, etc.), and assign them to specific zones.

Press to select the zone name you wish to record, for example "VOICE LOC. #01" - the display alternates with the current recording for zone name, for example, "Dining room". Record zone names; the procedure is identical to the "RECORD HOUSE ID" recording procedure described above.

Click to navigate between zone name numbers.

When done, press to return.

IMPORTANT!

1. The editing of a custom zone name automatically deletes the original text and recorded voice name. Make sure to record a new voice name.
2. Performing reset of factory defaults (see section 5.11) restores the original recordings for the zone name.

¹ Refers to WP80130 with voice option only

5.8.3 Voice Box Mode¹

This mode allows you to determine whether two-way voice communication is to be sounded either via an external speakerphone, via the control panel, or via both.

For the two-way voice communication procedure, follow the instructions below. Additional details and guidance are provided in section 5.2.



Enter "VOICE BOX MODE", and then refer to the table below which provides you with the options.

VOICE BOX MODE	Define whether two-way voice communication is to be sounded either via the external speakerphone ("VOICE BOX ONLY"), via the control panel ("NO VOICE BOX"), or via both ("VOICE BOX MIXED").
-----------------------	---

Options: NO VOICE BOX; VOICE BOX ONLY and VOICE BOX MIXED (default)

5.9 Diagnostics

5.9.1 General Guidance – "Diagnostics" Flow-Chart & Menu Options

The DIAGNOSTICS menu enables you to test your system and to verify proper operation of your WP8010/WP8030 panel, wireless devices attached to it and the communication (GSM/GPRS/SIM) modules.

IMPORTANT! *Reliable reception must be assured during the initial testing and also throughout subsequent system maintenance. A device should not be installed in location where signal strength is "poor". If you get "poor" signal strength from a certain device, simply re-locate it and re-test until a "good" or "strong" signal strength is received. This principle should be followed throughout the diagnostic test procedure.*

Note: For UL installations, "strong" signal strength for WL Devices is required.

The diagnostic test process is shown below.

The "07.DIAGNOSTICS" menu contains several sub-menu options, each covering a group of configurable features and parameters related to the communication and reporting as follows (see the list in Step 3 of the chart below):

Option	Description of Option Features and Parameters	Section
WL DEVICES	Describes how to test the devices attached to the WP8010/WP8030 panel, review devices' status and RF signal status. You can test all devices, test single device, review devices status and review RF problems, in case of any.	5.9.2
GSM/GPRS	Describes how to test the GSM/GPRS communication module.	5.9.3
SIM NUMBER TEST²	Tests the SIM number to ensure correct entry of the SIM number in the control panel.	5.9.4
BROADBAND MODULE^{3,4}	Enables to test the communication of the Broadband Module with the PowerManage server.	5.9.5

To enter the "07.DIAGNOSTICS" menu and to select and configure an option, proceed as follows:

Step 1	Step 2	Step 3	Step 4
Select "07.DIAGNOSTICS"	Select sub-menu option	Select the diagnostics you want to perform	
			See 5.9.2

¹ Refers to WP8030 with voice option only

² SIM number test is not applicable for UL installations

³ Broadband is not applicable for UL installations

⁴ The name of the product is PowerLink3 IP Communicator

3. WP8010 INSTALLATION

GSM/GPRS	OK		5.9.3
↓			
SIM NUMBER TEST ¹	OK	Tst by IP RCVR 1 Tst by IP RCVR 2	5.9.4
		OK SIM# verified	
↓			
BROADBAND MODULE ²	OK	PLEASE WAIT... Unit is OK	5.9.5

5.9.2 Testing Wireless Devices

The WP8010/WP8030 enable to test the wireless devices attached to the panel. You can test all devices, one device at a time, display devices' status and review RF problems, in case of any.

07:DIAGNOSTICS OK ►► ... ►► WL DEVICES OK ►► ... ►► MENU you wish OK

Enter the "WL DEVICES" menu, select the type of test you wish to perform (see guidance above and in section 5.9.1), then refer to the table below which provides you with detailed explanations for each option.

Option	Instructions
TEST ALL DEVICES	<p>You can test all wall-mounted devices automatically, one after the other, after which the installer tests the other devices in the following order: vanishing magnetic contact devices, keyfobs and then panic buttons.</p> <p>While in "TEST ALL DEVICES", press OK to initiate the test. The following screen will appear: "TESTING Xxx NNN", where "Xxx" indicates the type of device and "NNN" indicates the number of enrolled devices in the panel that have not been tested yet. This number automatically drops one count for every tested device.</p> <p>Pressing any key during the testing process will open the following options:</p> <ol style="list-style-type: none"> 1. Press ►► to jump to the next device group. For example, from wall-mounted devices to keyfobs. 2. Press OK to continue the testing process 3. Press 🔒 to exit the test process. <p>When all wall-mounted devices have completed the test procedure, you can test vanishing magnetic contact devices.</p> <p>While in the vanishing test process, indicated by the corresponding display, for example, "TEST VANISH NNN", momentarily open the door or window.</p> <p>When all vanishing magnetic contact devices have been tested, you can test keyfobs.</p> <p>While in the keyfobs test process, indicated by the corresponding display, for example, "TEST KEYFOBS NN", press any key of the selected device to initiate the test.</p> <p>When all keyfobs have been tested, you can test panic buttons.</p> <p>While in the panic button test process, indicated by the corresponding display, for example, "TEST PANIC BT. NN", press a button on the pendant.</p> <p>At the end of the test process, the panel will present the following: "SHOW ALL DEVICES". Press OK to view devices' status.</p> <p>Note: Refer to "SHOW ALL DEVICES" section below for further information on device status.</p>
TEST ONE DEVICE	<p>You can select a specific device group you wish to test, for example, Motion Sensors.</p> <p>Press OK to enter the "TEST ONE DEVICE" sub menu and use ►► to scroll through the device families. Press OK to enter the <device family> sub menu, for example: "MOTION SENSORS".</p> <p>Note: If there is no enrolled device, "NO EXISTING DEV." will be displayed.</p> <p>The following screens will then appear: "Xxx:<device name>" ↻ "<location>"</p> <p>Where Xxx indicates the device number. You can now select a specific device.</p> <p>Press OK to test the selected device. The following screen will appear: "TESTING Xxx 001".</p> <p>While in the keyfobs, panic button or vanishing magnetic contact test process, indicated by the corresponding display, for example, "Xxx ACTIVATE NOW", press any key of the selected keyfob or panic button, or momentarily open the door or window to initiate the test.</p>
→CONTACT SENSORS	
→MOTION SENSORS	
→GLASSBREAK SENS.	
→SHOCK SENSORS	
→SMOKE SENSORS	
→CO SENSORS	
→GAS SENSORS	
→FLOOD SENSORS	
→TEMPERATURE SENS.	
→KEYFOBS	
→PANIC BUTTONS	

¹ SIM number test is not applicable for UL installations

² Broadband is not applicable for UL installations

Option	Instructions
→KEYPADS →SIRENS →REPEATERS	At the end of the test process, the panel will present the devices' status: "Xxx: 24hr: <status>" ¹ ↩ "Xxx: NOW: <status>" ¹ . Note: Refer to "SHOW ALL DEVICES" section for further information on device status.
SHOW ALL DEVICES	You can view the devices status. Note: This option is available only after testing process was done. Press OK to view the devices' status. The following screens will appear: "Xxx: 24hr: <status>" ¹ ↩ "Xxx: NOW: <status>" ¹ Use ▶ to scroll between the device's families. To view additional information of the selected device, press OK . The following screens will appear: " Xxx <device name>" ¹ ↩ " <location>" ¹ . If the control panel receives information via a repeater, it will be displayed as follows: "Xxx <device name>" ¹ ↩ " <location>" ¹ ↩ "RPx:Via Repeater"↩
SHOW RF PROBLEMS	You can view only the devices which have RF problems. Note: This option is available only after testing process was done. Press OK to view the devices' status. The following screens will appear: "Xxx: 24hr: <status>" ¹ ↩ "Xxx: NOW: <status>" ¹ Use ▶ to scroll between the device's families. To view additional information of the selected device, press OK . The following screens will appear: " Xxx <device name>" ¹ ↩ " <location>" ¹ . If the control panel receives information via a repeater, it will be displayed as follows: "Xxx <device name>" ¹ ↩ " <location>" ¹ ↩ "RPx:Via Repeater"↩
<OK> TO END	Select to terminate the diagnostics test.

5.9.3 Testing the GSM module

The WP8010/WP8030 enable to test the GSM module integrated inside the panel.

07:DIAGNOSTICS **OK** **▶** ... **▶** GSM/GPRS **OK** Please wait...

Enter the "GSM/GPRS" menu, and press **OK** to initiate the GSM diagnostic test. Upon test completion, the WP8010/WP8030 will present the test result.

The following table presents the test result messages

Message	Description
Unit is OK	GSM / GPRS is functioning correctly
GSM comm. loss	GSM/GPRS module does not communicate with the Panel
Pin code fail	Missing or wrong PIN code. (Only if SIM card PIN code is enabled.)
GSM net. fail	Unit failed with registration to local GSM network.
SIM card fail	SIM not installed or SIM card failure.
GSM not detected	GSM auto enroll failed to detect GSM/GPRS module.
No GPRS service	The SIM card does not have the GPRS service enabled.
GPRS conn. fail	Local GPRS network is not available or, wrong setting to GPRS APN, user and/or password.
Srvr unavailable	PowerManage receiver cannot be reached – Check the Server IP
IP not defined	Server IP #1 and #2 are not configured.
APN not defined	APN is not configured.
SIM card locked	After entering a wrong PIN code 3 consecutive times the SIM is locked. To unlock it enter a PUK number. The PUK number cannot be entered by the control panel.
Denied by server	PowerManage denies the connection request. Check that the panel is registered to PowerManage

¹ The signal strength indications are as follows: "STRONG"; "GOOD"; "POOR"; "1-WAY" (the device operates in 1-way mode or, the "NOW" communication test failed); "NOT TST" (results are shown without any performed test); "NOT NET" [device is not networked (not fully enrolled)]; "NONE" (keyfob 24Hr result); or "EARLY" (result of the last 24Hrs without statistics).

3. WP8010 INSTALLATION

5.9.4 Testing the SIM Number¹

The WP8010/WP8030 enables to test the SIM number to ensure the SIM number was entered correctly in the control panel (see section 5.6.3) and to coordinate with the operator.

07:DIAGNOSTICS **OK** >> ... >> **SIM NUMBER TEST** **OK** ...

Enter the "SIM NUMBER TEST" menu, select the IP server (out of two) used for the verification of the SIM and press **OK**. The panel sends a test SMS to the server.

If the server receives the SMS, the control panel will display "**SIM# verified**" and the test ends successfully. If the SMS was not received, for example, if there is no connection between the control panel and server, the control panel will display "**SIM not verified**".

5.9.5 Testing the Broadband/PowerLink Module^{2, 3}

The Broadband diagnostic procedure enables to test the communication of the Broadband Module (see section 5.6.8) with the PowerManage server and reports the diagnostic result. In case of communication failure, detailed information of the failure is reported.

07:DIAGNOSTICS **OK** >> ... >> **BROADBAND MODULE** **OK** ... PLEASE WAIT... Unit is OK

Notes:

1. When the **OK** button is pressed, the test result may take up to 4 min. before it is displayed.
2. If the Broadband Module is not registered to the WP8010/WP8030, the menu "BROADBAND MODULE" will not be displayed.

The following table presents the list of messages that may be reported:

Message	Description
Unit is ok	Broadband Module is functioning correctly.
Test aborted	The diagnostic test is aborted, as follows: <ul style="list-style-type: none">• AC failure – Broadband Module is set to OFF mode.• Broadband Module has not completed the power-up procedure. In this case, the installer should wait a maximum of 30 seconds before re-testing.
Comm. loss	The RS-232 serial interface between the Broadband Module and the WP8010/WP8030 failed.
Rcvr Ip missing	Receivers IP 1 and 2 settings are missing in the WP8010/WP8030.
Cable unplugged	The Ethernet cable is not connected to the Broadband Module.
Check lan config	This message appears in any of the following cases: <ul style="list-style-type: none">• Incorrect Broadband Module IP has been entered.• Incorrect subnet mask has been entered.• Incorrect default gateway has been entered.• DHCP server failure.
Rcvr#1 UnReach. Rcvr#2 UnReach.	Receiver 1 or 2 is inaccessible, as follows: <ul style="list-style-type: none">• Wrong receiver IP has been entered.• Receiver failure.• WAN Network failure.
Rcvr#1 UnReg. Rcvr#2 UnReg.	The WP8010/WP8030 unit is not registered to IP receiver 1 or 2.
Timeout err.	Broadband Module does not respond to test result within 70 sec.
Invalid result	Broadband Module responds with a result code that is not recognized by the WP8010/WP8030.

5.10 User Settings

This USER SETTINGS menu provides you with a gateway to the user settings menu through the regular user menus. Refer to the WP8010/WP8030 User's Guide for detailed procedures.

¹ SIM number test is not applicable for UL installations

² Broadband is not applicable for UL installations

³ The name of the product is PowerLink3 IP Communicator

5.11 Factory Default

The FACTORY DEFLT menu enables you to reset the WP8010/WP8030 parameters to the factory default parameters. To obtain the relevant parameters defaults, contact the WP8010/WP8030 dealer. Reset factory default parameters as follows:

Step 1	Step 2	Step 3	Step 4	Step 5
Select "09:FACTORY DEFLT" menu	Select "<OK> to restore"	Enter Installer Code	Resetting of factory default parameters is underway	
09:FACTORY DEFLT <OK> to restore ENTER CODE: ■ PLEASE WAIT... to Step 1				

Notes:

- 1) For WP8010/WP8030 with 2 installer codes, INSTALLER code and MASTER INSTALLER code, only the master installer code enables to perform the factory default function.
- 2) If the Soak Test¹ is active, performing factory default will restart the Soak Test.

5.12 Serial Number

The SERIAL NUMBER menu enables reading the system serial number and similar data for support purposes only. To read the system serial number and other relevant data proceed as follows:

Step 1	Step 2	Step 3																						
Select "10:SERIAL NUMBER" menu	Click next repeatedly to view relevant data.																							
10:SERIAL NUMBER to Step 1																								
<table border="1"> <thead> <tr> <th></th> <th>Definition</th> </tr> </thead> <tbody> <tr> <td>0907030000.</td> <td>Control panel serial number</td> </tr> <tr> <td>JS702271 I18.040</td> <td>WP8010panel software version</td> </tr> <tr> <td>JS702275 K18.040</td> <td>WP8030panel software version</td> </tr> <tr> <td>JS700421 v1.0.02²</td> <td>Control panel keypad software version</td> </tr> <tr> <td>PANEL ID 305963</td> <td>Control panel ID for PowerManage connectivity</td> </tr> <tr> <td>PYTHON: 2.0.6¹</td> <td>GSM image transfer software version</td> </tr> <tr> <td>J-702xxx I18.040</td> <td>WP8010panel default version</td> </tr> <tr> <td>J-702xxx K18.040</td> <td>WP8030panel default version</td> </tr> <tr> <td>JS702412 K01.022</td> <td>Control panel boot version</td> </tr> <tr> <td>JS702415 K02.000</td> <td>Control panel Remote Software Upgrade downloader version</td> </tr> </tbody> </table>				Definition	0907030000.	Control panel serial number	JS702271 I18.040	WP8010panel software version	JS702275 K18.040	WP8030panel software version	JS700421 v1.0.02 ²	Control panel keypad software version	PANEL ID 305963	Control panel ID for PowerManage connectivity	PYTHON: 2.0.6 ¹	GSM image transfer software version	J-702xxx I18.040	WP8010panel default version	J-702xxx K18.040	WP8030panel default version	JS702412 K01.022	Control panel boot version	JS702415 K02.000	Control panel Remote Software Upgrade downloader version
	Definition																							
0907030000.	Control panel serial number																							
JS702271 I18.040	WP8010panel software version																							
JS702275 K18.040	WP8030panel software version																							
JS700421 v1.0.02 ²	Control panel keypad software version																							
PANEL ID 305963	Control panel ID for PowerManage connectivity																							
PYTHON: 2.0.6 ¹	GSM image transfer software version																							
J-702xxx I18.040	WP8010panel default version																							
J-702xxx K18.040	WP8030panel default version																							
JS702412 K01.022	Control panel boot version																							
JS702415 K02.000	Control panel Remote Software Upgrade downloader version																							

5.13 Partitioning

5.13.1 General Guidance – "Partitioning" Menu

This menu allows you to enable/disable partitions in the system (for further details, see APPENDIX B).

5.13.2 Enabling / Disabling Partitions

To enable or disable the partition feature, proceed as follows:

Step 1	Step 2	Step 3	Step 4
Select "12:PARTITIONING" menu	Select whether to "Enable" or "Disable" Partitions	Partitions are now enabled	
12:PARTITIONING Disable ■ Enable ■ to Step 1			
↓ Enable			

¹ Soak Test is not applicable for UL installations

² Refers to WP8030 only

3. WP8010 INSTALLATION

5.14 Operation Mode

Notes:







1. The Operation Mode feature is applicable only in specific WP8010/WP8030 variants.
2. For UL installations, Operation Mode must be "normal".

5.14.1 General Guidance – "Operation Mode" Menu

This mode allows you to select an operation mode for the control panel according to specific compliance standards. Each operation mode has its own configuration.

5.14.2 Select setting

To select the desired operation mode, proceed as follows:

Step 1	Step 2	Step 3	Step 4
Select "13:OPERATION MOD" menu	Enter "01:SELECT MODE"	Select "Normal", "EN-50131", "DD243", "BS8243", "INCERT" or "CP01"	
 13:OPERATION MOD 	 01 SELECT MODE 	 Normal 	 to Step 2

Note: If "Normal / EN-50131 / INCERT" is selected, the control panel will operate according to OTHERS setup configuration (see section 5.14.6).

5.14.3 BS8243 Setup



Enter the "02:BS8243 SETUP" menu to configure its settings.

Option	Configuration Instructions
01:DISARM OPTION	<p>Define when it is possible to disarm the system:</p> <p>entry/BS devs (default) – By keypad after the entry delay has expired and if an alarm occurred in the system. By keyfob or WP-TOUCH (868-3:037) at all times.</p> <p>entry/all devs - During entry delay, when the system is armed AWAY, by all devices. When not in entry delay by keyfob or WP-TOUCH (868-3:037)only.</p> <p>entry/DD devs - During entry delay, when the system is armed AWAY, by using the keyfob or WP-TOUCH (868-3:037)Keypads cannot disarm at all.</p> <p>anytime/all dev – At any time and by all devices.</p>
02:ENTRY ALARM	<p>Define whether the system will report a confirmed alarm during an entry delay (see CONFIRM ALARM below).</p> <p>BS8243 (default) – An alarm initiated by another detector during the entry delay is regarded as a confirmed alarm. An additional 30 seconds delay is added to the entry delay for reporting the event (does not affect the Abort Time, see section 5.5.4).</p> <p>BS8243 no cnfrm - The panel will not send any confirmed alarm once a delay zone has been activated, until the control panel is disarmed.</p> <p>DD243 - An alarm initiated by another detector during the entry delay is not regarded as a confirmed alarm.</p> <p>normal mode - The control panel will report a confirmed alarm for the second alarm that is triggered from a different zone within the confirmation time. There are no alarm restrictions during entry delay or for the delay zone.</p>
03:END EXIT MODE	<p>Define how the exit delay is terminated or restarted according to the following options:</p> <p>door/fob only (default) - When the door is closed, or by pressing the AUX button on the keyfob¹, whichever first.</p> <p>restart>reentry - Exit delay restarts when the door is reopened during exit delay. The restart occurs once only. Restarting the exit delay is helpful if the user re-enters immediately after going out to retrieve an item that was left behind.</p> <p>door/fob/timer - When the door is closed, by pressing the AUX button on the keyfob¹, or when the exit delay has expired, whichever first.</p> <p>fob/timer - By pressing the AUX button on the keyfob¹, or when the exit delay has expired, whichever first.</p>

¹ Applies only when the keyfob is defined as "skip exit delay" (for further details, see the keyfob's User's Guide)

Option	Configuration Instructions
04:FOB/KP PANIC	Define the devices that cannot trigger a panic alarm. BS8243 (default) – PG9939and PG9929 all - All devices can trigger a panic alarm
05:CONFIRM ALARM	Define a specific time period that if 2 successive alarms occur, the second alarm will be considered as a confirmed alarm , (see RPT CNFM ALRM below). Options: in 30 (default)/ 45/60/90 minutes
06:CONFIRM PANIC	A confirmed panic alarm is reported if one of the following occurs within the confirmation time: a) A second panic device is activated. b) A second panic alarm on the same device is activated. c) A tamper event is activated (not from the zone / device that initiated the panic alarm). Options: in 4/8/12/20 (default)/ 24 hours and disabled
07:RPT CNFM ALRM	Define whether the system will report a confirmed alarm. enable + bypass (default) - The system will report a confirmed alarm and will bypass all alarmed open zones when the siren ends or when the confirmation timer expires. disable - The system will not report a confirmed alarm. enable - The system will report a confirmed alarm.
08:ENTRY DELAY 1 09:ENTRY DELAY 2	Two different entry delays allow the user to enter the protected site (while the system is in the armed state) via 2 specific doors and routes without causing an alarm. Following entry, the user must disarm the control panel before the entry delay expires. Slow-rate warning beeps start sounding once the door is opened, until the last 10 seconds of the delay, during which the beeping rate increases. Locations No. 1 (entry delay 1) and 2 (entry delay 2) allow you to program the length of these delays. Options: 10/15/30 (ENTRY DELAY 1 default)/ 45/60 (ENTRY DELAY 2 default) seconds; 3/4 minutes
10:ABORT TIME	The WP8010/WP8030 can be configured to provide a delay before reporting an alarm to the monitoring station (not applicable to alarms from FIRE, 24H SILENT and EMERGENCY zones). During this delay period, the siren sounds but the alarm is not reported. If the user disarms the system within the delay time, the alarm is aborted. You can activate the feature and select the "Abort Time" interval. Options: in 00 (default in USA)/ 15/30 (default)/ 45/60 seconds; in 2/3/4 minutes
11:CANCEL ALARM	The WP8010/WP8030 can be configured to provide a "Cancel Alarm" time window that starts upon reporting an alarm to the Monitoring Station. If the user disarms the system within that "cancel alarm" time, a "cancel alarm" message is sent to the Monitoring Station indicating that the alarm was canceled by the user. Options: not active (default in USA); in 1/5 (default)/ 15/60 minute(s) and in 4 hours.

5.14.4 DD243 Setup

13:OPERATION MOD   ...  03:DD243 SETUP 

Enter the "03:DD243 SETUP" menu to configure its settings.

Option	Configuration Instructions
01:DISARM OPTION	Define when it is possible to disarm the system: entry/wl+awy kp – By the control panel when the system is armed AWAY. By keyfob or WP-TOUCH (868-3:037) during entry delay only. entry/all devs - During entry delay, when the system is armed AWAY, by all devices. When not in entry delay by keyfob or WP-TOUCH (868-3:037)only. entry/DD devs (default) - During entry delay, when the system is armed AWAY, by using the keyfob or WP-TOUCH (868-3:037). Keypads cannot disarm at all. anytime/all dev – At any time and by all devices.

3. WP8010 INSTALLATION

Option	Configuration Instructions
02:ENTRY ALARM	<p>Define whether the system will report a confirmed alarm during an entry delay (see CONFIRM ALARM below).</p> <p>DD243 (default) - An alarm initiated by another detector during the entry delay is not regarded as a confirmed alarm.</p> <p>normal mode - The control panel will report a confirmed alarm for the second alarm that is triggered from a different zone within the confirmation time. There are no alarm restrictions during entry delay or for the delay zone.</p>
03:END EXIT MODE	<p>Define how the exit delay is terminated or restarted according to the following options:</p> <p>door/fob only - When the door is closed, or by pressing the AUX button on the keyfob¹, whichever first.</p> <p>restart>reentry - Exit delay restarts when the door is reopened during exit delay. The restart occurs once only. Restarting the exit delay is helpful if the user re-enters immediately after going out to retrieve an item that was left behind.</p> <p>door/fob/timer - When the door is closed, by pressing the AUX button on the keyfob¹, or when the exit delay has expired, whichever first.</p> <p>fob/timer (default) - By pressing the AUX button on the keyfob¹, or when the exit delay has expired, whichever first.</p>
04:FOB/KP PANIC	<p>Define the devices that cannot trigger a panic alarm.</p> <p>DD243 (default) – PG9939 and PG9929</p> <p>all - All devices can trigger a panic alarm</p>
05:CONFIRM ALARM	<p>Define a specific time period that if 2 successive alarms occur, the second alarm will be considered as a confirmed alarm, (see RPT CNFM ALRM below).</p> <p>Options: in 30/45/60(default)/90 minutes</p>
06:CONFIRM PANIC	<p>A confirmed panic alarm is reported if one of the following occurs within the confirmation time:</p> <ul style="list-style-type: none">a) A second panic device is activated.b) A second panic alarm on the same device is activated.c) A tamper event is activated (not from the zone / device that initiated the panic alarm). <p>Options: in 4/8/12/20(default)/24 hours and disabled</p>
07:RPT CNFM ALRM	<p>Define whether the system will report a confirmed alarm.</p> <p>enable + bypass (default) - The system will report a confirmed alarm and will bypass all alarmed open zones when the siren ends or when the confirmation timer expires.</p> <p>disable - The system will not report a confirmed alarm.</p> <p>enable - The system will report a confirmed alarm.</p>
08:ENTRY DELAY 1 09:ENTRY DELAY 2	<p>Two different entry delays allow the user to enter the protected site (while the system is in the armed state) via 2 specific doors and routes without causing an alarm.</p> <p>Following entry, the user must disarm the control panel before the entry delay expires. Slow-rate warning beeps start sounding once the door is opened, until the last 10 seconds of the delay, during which the beeping rate increases. Locations No. 1 (entry delay 1) and 2 (entry delay 2) allow you to program the length of these delays.</p> <p>Options: 10/15/30(ENTRY DELAY 1 default)/45/60(ENTRY DELAY 2 default) seconds; 3/4 minutes</p>
10:ABORT TIME	<p>The WP8010/WP8030 can be configured to provide a delay before reporting an alarm to the monitoring station (not applicable to alarms from FIRE, 24H SILENT and EMERGENCY zones). During this delay period, the siren sounds but the alarm is not reported. If the user disarms the system within the delay time, the alarm is aborted. You can activate the feature and select the "Abort Time" interval.</p> <p>Options: in 00 (default in USA)/15/30 (default)/45/60 seconds; in 2/3/4 minutes</p>

¹ Applies only when the keyfob is defined as "skip exit delay" (for further details, see the keyfob's User's Guide)

Option	Configuration Instructions
11:CANCEL ALARM	The WP8010/WP8030 can be configured to provide a "Cancel Alarm" time window that starts upon reporting an alarm to the Monitoring Station. If the user disarms the system within that "cancel alarm" time, a "cancel alarm" message is sent to the Monitoring Station indicating that the alarm was canceled by the user. Options: not active (default in USA); in 1/5 (default)/ 15/60 minute(s) and in 4 hours .

5.14.5 CP01 Setup

13:OPERATION MOD   ...  CP01 SETUP 

Enter the "04:CP01 SETUP" menu to configure its settings.

Option	Configuration Instructions
01:DISARM OPTION	Certain regulations require that when the system is armed in AWAY mode, it may not be disarmed from the outside of the house (such as by keyfobs) before entering the protected premises and activating an "Entry Delay" zone. To answer this requirement, the WP8010/WP8030 provides you with the following configurable options to disarm the system: any time (default), the system can be disarmed at all times from all devices. on entry wrless - During entry delay, the system can be disarmed only using keyfob or prox operated devices. entry + away kp. - During entry delay by code, the system can be disarmed only using WP8010/WP8030 panel keypad. on entry all. - During entry delay, the system can be disarmed using keyfobs or by code using the WP8010/WP8030 panel keypad.
03:END EXIT MODE	Define how the exit delay is terminated or restarted according to the following options: restart+arm home (default) – During exit delay if the door was not opened, the alarm system will be armed HOME instead of armed AWAY. restart>reentry - Exit delay restarts when the door is reopened during exit delay. The restart occurs once only. Restarting the exit delay is helpful if the user re-enters immediately after going out to retrieve an item that was left behind. door/fob/timer - When the door is closed, by pressing the AUX button on the keyfob ¹ , or when the exit delay has expired, whichever first. fob/timer - By pressing the AUX button on the keyfob ¹ , or when the exit delay has expired, whichever first.
05:CONFIRM ALARM	Define a specific time period that if 2 successive alarms occur, the second alarm will be considered as a confirmed alarm, (see RPT CNFM ALRM below). Options: disable (default in USA); in 30/45/60 (default)/ 90 minutes
07:RPT CNFM ALRM	Define whether the system will report a confirmed alarm. report disabled (default) - The system will not report a confirmed alarm. report enabled - The system will report a confirmed alarm.
08:ENTRY DELAY 1 09:ENTRY DELAY 2	Two different entry delays allow the user to enter the protected site (while the system is in the armed state) via 2 specific doors and routes without causing an alarm. Following entry, the user must disarm the control panel before the entry delay expires. Slow-rate warning beeps start sounding once the door is opened, until the last 10 seconds of the delay, during which the beeping rate increases. Locations No. 1 (entry delay 1) and 2 (entry delay 2) allow you to program the length of these delays. Options: 30 (default)/ 45/60 seconds ; 3/4 minutes
10:ABORT TIME	The WP8010/WP8030 can be configured to provide a delay before reporting an alarm to the monitoring station (not applicable to alarms from FIRE, 24H SILENT, EMERGENCY, GAS FLOOD and TEMPERATURE zones). During this delay period, the external siren will not sound and the alarm is not reported. If the user disarms the system within the delay time, the alarm is aborted. Options: in 15 (default)/ 30/45 seconds

¹ Applies only when the keyfob is defined as "skip exit delay" (for further details, see the keyfob's User's Guide)

3. WP8010 INSTALLATION

Option	Configuration Instructions
11:CANCEL ALARM	Define the "cancel alarm" period that starts upon reporting an alarm to the Monitoring Station. If the user disarms the system within that time period, a "cancel alarm" message is sent to the Monitoring Station. Options: in 5 (default)/15/60 minutes; in 4 hours
12:CNCEL ANOUNCE	Define whether a special beep will sound when an alarm cancel event is sent to the monitoring station. enable (default) and disable
13:ABORT ANOUNCE	Define that when the user disarms the system within the allowed abort interval a special beep will sound to indicate "no alarm transmission". enable (default) and disable

5.14.6 OTHERS Setup



Enter the "05:OTHERS SETUP" menu to configure its settings.

Option	Configuration Instructions
01:DISARM OPTION	Certain regulations require that when the system is armed in AWAY mode, it may not be disarmed from the outside of the house (such as by keyfobs) before entering the protected premises and activating an "Entry Delay" zone. To answer this requirement, the WP8010/WP8030 provides you with the following configurable options to disarm the system: any time (default), the system can be disarmed at all times from all devices. on entry wrless - During entry delay, the system can be disarmed only using keyfob or prox operated devices. entry + away kp. - During entry delay by code, the system can be disarmed only using WP8010/WP8030 panel keypad. on entry all. - During entry delay, the system can be disarmed by code using the WP8010/WP8030 panel keypad or by keyfobs at all times.
03:END EXIT MODE	The "Exit Delay" time can be further adjusted according to your preferred exit route. The control panel provides you with the following "Exit Mode" options: A: "normal" (default) - The exit delay is exactly as defined. B: "restart>reentry" - The exit delay restarts when the door is reopened during exit delay. The restart occurs once only. Restarting the exit delay is helpful if the user re-enters immediately after going out to retrieve an item that he left behind. C: "end by exit" - The exit delay expires (ends) automatically when the exit door is closed even if the defined exit delay time was not completed. Options: normal (default); restart>reentry and end by exit .
05:CONFIRM ALARM	Define a specific time period that if 2 successive alarms occur, the second alarm will be considered as a confirmed alarm, (see RPT CNFM ALRM below). Options: disable (default in USA); in 30/45/60 (default)/90 minutes
07:RPT CNFM ALRM	Define whether the system will report a confirmed alarm. report disabled (default) - The system will not report a confirmed alarm. enabled+bypass - The system will report a confirmed alarm and will bypass all alarmed open zones when the siren ends or when the confirmation timer expires. report enabled - The system will report a confirmed alarm.
08:ENTRY DELAY 1 09:ENTRY DELAY 2	Two different entry delays allow the user to enter the protected site (while the system is in the armed state) via 2 specific doors and routes without causing an alarm. Following entry, the user must disarm the control panel before the entry delay expires. Slow-rate warning beeps start sounding once the door is opened, until the last 10 seconds of the delay, during which the beeping rate increases. Locations No. 1 (entry delay 1) and 2 (entry delay 2) allow you to program the length of these delays. Options : 00/15 (ENTRY DELAY 2 default)/30 (ENTRY DELAY 1 default)/45/60 seconds; 3/4 minutes



Option	Configuration Instructions
10:ABORT TIME	<p>The WP8010/WP8030 can be configured to provide a delay before reporting an alarm to the monitoring station (not applicable to alarms from FIRE, 24H SILENT and EMERGENCY zones). During this delay period, the siren sounds but the alarm is not reported. If the user disarms the system within the delay time, the alarm is aborted. You can activate the feature and select the "Abort Time" interval.</p>
	<p>Options: in 00 (default in USA)/15/30(default)/45/60 seconds; in 2/3/4 minutes</p>
11:CANCEL ALARM	<p>The WP8010/WP8030 can be configured to provide a "Cancel Alarm" time window that starts upon reporting an alarm to the Monitoring Station. If the user disarms the system within that "cancel alarm" time, a "cancel alarm" message is sent to the Monitoring Station indicating that the alarm was canceled by the user.</p>
	<p>Options: not active (default in USA); in 1/5 (default)/15/60 minute(s) and in 4 hours.</p>

6. PERIODIC TEST

6.1 General Guidance



This mode provides you with the means to conduct a periodic test of all system sirens, detectors, keyfobs, keypads, repeaters and other peripheral devices, via the "PERIODIC TEST" menu, at least once a week and after an alarm event. When you are instructed to perform a periodic test, walk throughout the site to check the detectors / sensors (except for Sirens and Temperature Sensors). When a detector/sensor is triggered into alarm, its name, number and the alarm reception level should be indicated (for example, "Bathroom", "Z19 strong") and the buzzer should sound according to the alarm reception level (1 of 3). Each device should be tested according to the device Installation Instructions.

To enter the "PERIODIC TEST" menu and to conduct a periodic test, proceed as follows:

Step 1	①	Step 2	①
READY	[1]	Select the test to be performed	[2]
			
PERIODIC TEST (enter installer / master code)		SIRENS TEST TEMPERATURE TEST TEST ALL DEVICES TEST ONE DEVICE	

① ① – Periodic Test

[1] Not including Siren and Temperature Sensors

[2] After reviewing all untested devices the control panel will read "<OK> TO END". You can now do one of the following: press  to abort the testing procedure; press  to continue the testing procedure; or press  to exit the testing procedure.

6.2 Conducting a Periodic Test

The WP8010/WP8030 enables you to conduct the periodic test in four parts:

Siren Test: Each siren of the system is automatically activated for 3 seconds (outdoor sirens with low volume).







Temperature Sensor Test: When Temperature Sensors are enrolled in the system, the control panel displays the temperature of each zone in Celsius or Fahrenheit.

Test all devices: All devices are tested.

Other Device Test: Each of the other devices in the system is activated by the installer and the display indicates which devices were not yet tested. The "it's me" indication helps to identify the untested devices if necessary. A counter also indicates the number of devices that remain untested.





















READY   ...  PERIODIC TEST   ...  MENU you wish 

To conduct a periodic test, make sure the system is disarmed and then enter the "PERIODIC TEST" menu using your installer code (8888 by default) or master installer code (9999 by default). Immediately after entering the "PERIODIC TEST" menu, all 4 LED's on the panel will momentarily light (LED test).

Option	Instructions
SIRENS TEST	<p>You can test wireless sirens and strobes (including the control panel siren) and sirens of smoke sensors.</p> <p>To initiate the siren test, press  . The display now reads "SIREN N". "N" indicates the zone location assigned to the siren that is currently being tested.</p> <p>First the panel siren sounds for 3 seconds after which the WP8010/WP8030 system will automatically repeat the procedure for the next siren enrolled in the system until all sirens are tested. You should listen to the sirens sounds and make sure that all sirens sound.</p> <p>Once all the sirens have been tested, the control panel will now test the sirens of smoke sensors that are enrolled in the alarm system. The display now reads "Zxx: SMOKE SIREN", where "Zxx" indicates the zone number of the smoke sensor, and alternates with "<OK> TO CONTINUE". During this time, the siren of the tested smoke sensor will sound for up to one minute.</p> <p>Press   to test the siren of the next smoke sensor.</p> <p>When the sirens test is complete, the display reads "SIREN TESTS END". Press the   or the  button to confirm the test.</p>

Option	Instructions
TEMPERATURE TEST	<p>The control panel reads the temperature of the zone.</p> <p>To display the temperature of zones on the control panel, press ⓘ OK. The control panel reads the temperature of each zone. The display alternates between the temperature, the sensor number and the sensor location, as in the following example: "Z01 24.5°C" changes to "Z01:Temp. Sensor" changes to "Guest room". Repeatedly click the ▶▶ button to review the temperature of each zone (by Temperature Sensor).</p> <p>When the temperature of all zones has been reviewed, the display reads "DEVICE TESTS END". Press the ⓘ OK or the ▶▶ button to confirm the test and then move to the next step to test the other devices.</p>
TEST ALL DEVICES	<p>You can test all devices in one procedure.</p> <p>While in "TEST ALL DEVICES", press OK to initiate the test.</p> <p>The control panel now reads "NOT TESTED NNN". "N" indicates the number of enrolled devices in the control panel that have not been tested. This number automatically drops one count for every tested device.</p> <p>When the "NOT TESTED NNN" screen appears, walk throughout the site to test the detectors / sensors or press any key of the selected handheld device to initiate the test.</p> <p>After a device has been activated, the control panel reads "Zxx IS ACTIVATED" and the "N" indicator drops one count.</p> <p>Pressing OK during the testing process will display details of each device that has not yet been tested. The control panel reads the device number, followed by the device type (for example, Contact Sensor, Motion Sensor or Keyfob) and followed by the device location. At this stage, pressing any one of the following keys will open the following options:</p> <ol style="list-style-type: none"> 1. Press ▶▶ to view details of the next untested device. 2. Press 🔒 to exit the test process. <p>During testing, you can also check the signal strength indication of each device according to the number of LED blinks of the device, (for further details, refer to the device Installation Instructions).</p> <p>After all devices have been tested, the control panel reads "DEVICE TESTS END".</p>
TEST ONE DEVICE →CONTACT SENSORS →MOTION SENSORS →GLASSBREAK SENS. →SHOCK SENSORS	<p>Select a specific device group you wish to test. For example, Motion Sensors.</p> <p>Press OK to enter the "TEST ONE DEVICE" sub menu and use ▶▶ to scroll through the device families. Press OK to enter the < device family > sub menu For example: "MOTION SENSORS".</p> <p>The following screens will appear: "Xxx:<device name> ↻ <location>" Where "Xxx" indicates the device number.</p> <p>If there is no device, the following screen will appear: "NO EXISTING DEV.".</p> <p>Press OK to test the selected device. The following screen will appear: "Z01 ACTIVATE NOW".</p> <p>Walk throughout the site to test the detectors / sensors or press any key of the selected handheld device to initiate the test.</p> <p>During testing, you can also check the signal strength indication of each device, (for further details, refer to the device Installation Instructions).</p> <p>At the end of the test process the panel will revert to: "TEST ONE DEVICE".</p> <p>To test the microwave range of the dual detector:</p> <ol style="list-style-type: none"> 1. Press OK to enter the "TEST ONE DEVICE" sub menu and use ▶▶ to navigate to "MOTION SENSORS". 2. Press OK; the following screens will appear: "Z01:Motion Sens ↻ <location>". 3. Press ▶▶ continuously to select a different zone number. 4. Press OK; If the selected device is Tower-32AM PG2, the following screens will appear: "<OK MW ADJUST> ↻ "<NEXT> TEST ONE"".

3. WP8010 INSTALLATION

Option	Instructions
	<p>To test the microwave range, go to step 5. To test a different microwave range, go to step 7.</p> <ol style="list-style-type: none">5. Press ; the following screen will appear: "ACTIVATE MW NOW".6. Activate the device; the screen will return to "TEST ONE DEVICE". <p>You can now repeat the procedure for another dual detector.</p> <ol style="list-style-type: none">7. Press  to select the sensitivity setting.8. Press  continuously to select between "Minimum" (default), "Medium" or "Maximum".9a. Press ; the panel will receive an acknowledge from the device that is indicated by a black box next to the selected setting. Thereafter, the screen momentarily changes to "ACTIVATE MW NOW" and then returns to the selected setting.9b. If you press , the adjustment procedure ends. <p>Important: The procedure mentioned above is for testing purposes only and does not change the detector settings. The settings must be saved through the MODIFY DEVICES menu.</p> <p>To test the shock detector:</p> <ol style="list-style-type: none">1. Press  to enter the "TEST ONE DEVICE" sub menu and use  to navigate to "SHOCK SENSORS".2. Press ; the following screens will appear: "Zxx:Shk+AX+CntG3"¹  <location>.3. Press  continuously to select a different zone number.4. Press ; the following screens will appear: "Zxx ACTIVATE NOW"  "SHOCK NOT ACTIV."  "CNTACT NOT ACTIV"  "AUXIL. NOT ACTIV". <p><i>Note: The above screens are the full range of screens that can appear and indicate the inputs that have not yet been activated. However, since there are various models of the shock detector, not all of these screens will appear on some models.</i></p> <ol style="list-style-type: none">5. At this stage, activate each input of the shock detector in turn. <p>To test motion detector with integrated camera (PG9934 or PG9944):</p> <ol style="list-style-type: none">1. Press  to enter the "TEST ONE DEVICE" sub menu and use  to navigate to "MOTION SENSORS".2. Press ; the following screens will appear: "Z01:Motion Sens"  <location>.3. Press  continuously to select a different zone number.4. Press ; the following screen will appear: "Zxx ACTIVATE NOW".5. Activate the input of the detector; the following screens will appear: "<Zxx IS ACTIVATE>"  "<OK> SEND IMAGE".

¹ Depending on shock detector model, one of the following may appear instead: "**Zxx:Shk+AX**" / "**Zxx:Shk+CntG3**" / "**Zxx:Shk+CntG2**".

7. MAINTENANCE

7.1 Handling System Troubles

Fault	What it means	Possible Solution
1-WAY	The control panel cannot configure or control the device. Battery consumption increases.	<ul style="list-style-type: none"> • Make sure the device is physically present. • Check the display for device faults, for example, low battery. • Use RF diagnostics to check the current signal strength and during the last 24 hours. • Open the device cover and replace the battery or press the tamper switch. • Install the device in a different location. • Replace the device.
AC FAILURE	There is no power to gas sensor	Make sure that the AC power supply is connected properly
AC SUPPLY FAILURE	There is no power and the system is working on backup battery power	Make sure that the AC power supply is connected properly
CLEAN ME	The fire detector must be cleaned	Use a vacuum cleaner to clean the detector air vents occasionally to keep them free of dust.
COMM. FAILURE	A message could not be sent to the monitoring station or to a private telephone (or a message was sent but was not acknowledged)	<ul style="list-style-type: none"> • Check telephone cable connection • Check that correct telephone number has been dialed. • Dial Monitoring Station to check whether or not events are received.
CPU LOW BATTERY	The backup battery within the control panel is weak and must be replaced (see section 7.3, Replacing the Backup Battery).	<ul style="list-style-type: none"> • Check for AC power is available in the Panel. • If trouble exists for more than 72 hours, replace the battery pack
CPU TAMPER OPEN	The control panel was physically tampered with or its cover was opened, or it was removed from wall.	The control panel is not closed properly. Open the control panel and then close it.
FUSE TROUBLE	The PGM fuse is burnt out or overloaded.	Make sure that the connection load conforms to that specified in the Specifications.
GAS TROUBLE	Gas detector failure	Gas detector: Disconnect and then put back the AC power supply connector CO Gas detector: Replace the detector
GSM NET FAIL	The GSM communicator is not able to connect to the cellular network.	<ul style="list-style-type: none"> • Move the Panel and GSM unit to another location. • Enter and exit the installer menu • Disconnect GSM unit and install it again • Replace SIM card • Replace the GSM unit
JAMMING	A radio-frequency signal which is blocking communication channel of sensors and control panel is detected.	Locate the source of interference by switching off any wireless devices (cordless telephones, wireless ear plugs, etc.) in the house for 2 minutes then check if trouble continues. Use also RF diagnostics to check signal strength.
LINE FAILURE	There is a problem with the telephone line	<ul style="list-style-type: none"> • Lift the telephone receiver and make sure a telephone line can be heard • Check the telephone connection to the

3. WP8010 INSTALLATION

Fault	What it means	Possible Solution
		control panel
LOW BATTERY	The battery in a sensor, keyfob or wireless commander is near the end of its useful life.	<ul style="list-style-type: none"> For AC powered devices, check AC power is available and connected to the device. Replace the device battery.
MISSING	A device or detector has not reported for some time to the control panel.	<ul style="list-style-type: none"> Make sure the device is physically present. Check the display for device faults, for example, low battery. Use RF diagnostics to check the current signal strength and during the last 24 hours. Replace the battery. Replace the device.
NOT NETWORKED	A device was not installed or not installed correctly, or, cannot establish communication with the control panel after installation.	<ul style="list-style-type: none"> Make sure the device is physically present. Use RF diagnostics to check the current signal strength and during the last 24 hours. Open the device cover and replace the battery or press the tamper switch. Enroll the device again.
RSSI LOW	The GSM communicator has detected that GSM network signal is weak	Move the Panel and GSM unit to another location.
SIREN AC FAILURE	There is no power to the siren	Make sure that the AC power supply is connected properly
TAMPER OPEN	The sensor has an open tamper	Close sensor tamper
TROUBLE	The sensor reports trouble	Replace the sensor
SOAK TEST FAIL ¹	Detector alarms when in Soak Test mode	<p>If you wish to continue the Soak Test, no further action should be taken.</p> <p>If you wish to abort the Soak Test, disable the Soak Test (see section 5.4.6).</p>

7.2 Dismounting the Control Panel

A. Remove the screw that fastens the front unit to the back unit, see Figure 3.1 WP8010/ 4.1 WP8030**B.** Remove the 4 screws that fasten the back unit to the mounting surface - see Figure 3.1 (WP8010/ 4.1 WP8030) - and remove the control panel.

7.3 Replacing the Backup Battery

Replacement and first-time insertion of battery pack is similar, see Figure 3.8 (WP8010 / 4.10 WP8030).

With a fresh battery pack, correct insertion and tightened battery compartment lid, the TROUBLE indicator should extinguish. However, the "MEMORY" message will now blink in the display (caused by the "tamper" alarm you triggered when opening the battery compartment lid). Clear it by arming the system and immediately disarming.

7.4 Fuse Replacement

The WP8010has an internal fuse (the WP8030has two internal fuses) that has automatic reset. Therefore, there is no need to replace the fuse(s).

When over current condition occurs, the fuse cuts off the circuit current. Upon fault current being removed for several seconds, the fuse is automatically reset and allows current flow through the circuit again.

7.5 Replacing/Relocating Detectors

Whenever maintenance work involves replacement or re-location of detectors, always perform **a full diagnostic test according to section 5.9.**

Remember! A "poor" signal is not acceptable.

¹ Soak Test is not applicable for UL installations

7.6 Annual System Check

Note: *The WP8010/WP8030 system must be checked by a qualified technician at least once every three (3) years (preferably every year).*

The annual system check is designed to ensure proper operation of the alarm system by performing the following checks:

- Periodic test
- Arm/disarm function
- No trouble messages are displayed on control panel
- The clock displays the correct time
- Reporting: generating an event to be transmitted to the Monitoring Station and to the user.

8. READING THE EVENT LOG

Up to 100 events are stored in the event log. You can access this log and review the events, one by one. If the event log fills up completely, the oldest event is deleted upon registration of each new event. The date and time of occurrence are memorized for each event.

Note: Up to 250 events (WP8010) / 1000 events (WP8030) are stored in the event log that can be reviewed via the Remote Programmer PC software application or by the remote PowerManage server.

When reading the event log, events are shown in chronological order - from the newest to the oldest. Access to the event log is provided by clicking the button and not through the installer's menu. The reading and erasing process of the event log is shown below.

Step 1	Step 2	Step 3	Step 4
In normal operating mode [1]	Enter Installer Code [2]	Reviewing Events [3]	Scroll List of Events [4]
READY 00:00	ENTER CODE: ■ ↓ LIST OF EVENTS	Z13 alarm 09/02/11 3:37 P	SR2 TAMPER-ALARM 07/02/11 11:49 a
Step 5	Step 6	Step 7	Step 8
CLEAR EVENT LOG display [5]	Erase the Event Log [6]	Event Log is erased [7]	Returns to normal operating mode [8]
→	CLEAR EVENT LOG <OFF> to delete	<OK> TO EXIT	→ READY 00:00

①	① - Reading Events
[1]	While the system is in the normal operating mode, press the key.
	Reading the Event Log
[2]	Enter the current Installer Code and then press to enter "LIST OF EVENTS".
[3]	The latest event is shown. The event is displayed in two parts, for example, "Z13 alarm" then "09/02/10 3:37 P". Note: In Soak Test ¹ mode, the panel displays the alarmed zone and alternates with "Zxx:Soak T.Fail".
[4]	Press repeatedly to scroll through the list of events.
	Erasing and Exiting the Event Log:
[5]	From anywhere within the event log, press the button and then press .
[6]	At this stage in the procedure, clicking the or buttons will take you to "<OK> TO EXIT" without erasing the event log. Clicking the button will revert to "CLEAR EVENT LOG". Press the button to erase the event log.
[7]	The system erases the event log
[8]	Press to revert to normal operating mode.
	Clicking the button repeatedly at any stage in the procedure takes you one level up with each click. Clicking the button will take you to "<OK> TO EXIT".

¹ Soak Test is not applicable for UL installations

APPENDIX A. Specifications

A1. Functional

	WP8010	WP8030
Zones Number	30 wireless zones (including 1 hard-wired input).	Up to 64 wireless zones, (including 2 hard-wired inputs).
Hard-wired Zone Requirements	2.2 k Ω E.O.L. resistance (max. resistance of wires 220 Ω).	2.2 k Ω E.O.L. resistance (max. resistance of wires 220 Ω).
Maximum Loop Current	1.5 mA	1.5 mA
Maximum Loop Voltage	3.3 V	3.3 V
Loop Shorted	0.00 – 1.47 V (0.00 – 1.76 K Ω)	0.00 – 1.47 V (0.00 – 1.76K Ω)
Loop Normal	1.47 – 1.80 V (1.76-2.64 K Ω)	1.47 – 1.80 V (1.76 – 2.64 K Ω)
Loop Tampered	1.80 – 2.03 V (2.64-3.52 K Ω)	1.80 – 2.03 V (2.64 – 3.52 K Ω)
Loop Alarm	2.03 – 2.33 V (3.52-5.26 K Ω)	2.03 – 2.33 V (3.52 – 5.26 K Ω)
Loop Open	2.33 – 3.30 V (5.26 – ∞ Ω)	2.33 – 3.30 V (5.26 – ∞ Ω)
Installer and User Codes	<ul style="list-style-type: none"> • 1 master installer (9999 by default)* • 1 installer (8888 by default)* • 1 master user, no. 1 (1111 by default) • Users nos. 2 - 8 * Codes must not be identical	<ul style="list-style-type: none"> • 1 master installer (9999 by default)* • 1 installer (8888 by default)* • 1 master user, no. 1 (1111 by default) • Users nos. 2 - 48 * Codes must not be identical
Control Facilities	<ul style="list-style-type: none"> - Integral keypad, wireless keyfobs and keypads - SMS commands via optional GSM/GPRS module. Remote control by telephone. Note: For SIA CP-01 compliance, when using PG9939 an external siren must also be used. CP-01 features not to be enabled in UL Listed product.	<ul style="list-style-type: none"> - Integral keypad, wireless keyfobs and keypads - SMS commands via optional GSM/GPRS module. - Remote control by telephone. Note: For SIA CP-01 compliance, when using PG9939 an external siren must also be used. CP-01 features not to be enabled in UL Listed product.
Display	Single line, backlit 16-large character LCD.	Single line, backlit 16-large character LCD.
Arming Modes	AWAY, HOME, AWAY-INSTANT, HOME-INSTANT, LATCHKEY, FORCED, BYPASS. Note: AWAY-INSTANT and HOME-INSTANT are not permissible for CP-01 installations.	AWAY, HOME, AWAY-INSTANT, HOME-INSTANT, LATCHKEY, FORCED, BYPASS. Note: AWAY-INSTANT and HOME-INSTANT are not permissible for CP-01 installations.
Alarm Types	Silent, personal panic/emergency, burglary, gas (CO), and fire .	Silent, personal panic/emergency, burglary, gas (CO), and fire.
Siren Signals	<u>Continuous</u> (intrusion / 24 hours / panic); <u>triple pulse – short pause - triple pulse...</u> (fire); <u>four pulses – long pause – four pulses...</u> (gas); <u>long pulse – long pause – long pulse...</u> (flood).	<u>Continuous</u> (intrusion / 24 hours / panic); <u>triple pulse – short pause - triple pulse...</u> (fire); <u>four pulses – long pause – four pulses...</u> (gas); <u>long pulse – long pause – long pulse...</u> (flood).
Siren (bell) Timeout	Programmable (4 min. by default)	Programmable (4 min. by default)
Internal Sounder Output	At least 85 dBA at 10 ft. (3 m)	At least 85 dBA at 10 ft. (3 m)
Supervision	Programmable time frame for inactivity alert	Programmable time frame for inactivity alert
Special Functions	<ul style="list-style-type: none"> - Chime zones - Diagnostic test and event log. - Local and Remote Programming over Telephone, GSM /GPRS connections. - Calling for help by using an emergency transmitter. - Tracking inactivity of elderly, physically handicapped and infirm people. Note: Tracking inactivity of elderly not to be enabled in UL Listed product.	<ul style="list-style-type: none"> - Chime zones - Diagnostic test and event log. - Local and Remote Programming over Telephone, GSM /GPRS connections. - Calling for help by using an emergency transmitter. - Tracking inactivity of elderly, physically handicapped and infirm people. - Message center (recording and playback) - Two-way voice communication Note: Tracking inactivity of elderly not to be enabled in UL Listed product.
Data Retrieval	Alarm memory, trouble, event log	Alarm memory, trouble, event log

3. WP8010 INSTALLATION

	WP8010	WP8030
Real Time Clock (RTC)	The control panel keeps and displays time and date. This feature is also used for the log file by providing the date and time of each event	The control panel keeps and displays time and date. This feature is also used for the log file by providing the date and time of each event
Battery Test	Once every 10 seconds	Once every 10 seconds

A2. Wireless

	WP8010			WP8030		
RF Network	PowerG – 2-way synchronized Frequency Hopping (TDMA / FHSS)			PowerG – 2-way synchronized Frequency Hopping (TDMA / FHSS)		
Frequency bands (MHz)	433 – 434	868 - 869	912 – 919*	433 – 434	868 - 869	912 – 919*
Hopping frequencies	8	4	50	8	4	50
Region	Worldwide	Europe	North America and selected countries	Worldwide	Europe	North America and selected countries
Encryption	AES-128 <i>Note: AES-128 bit encryption for communication between control unit and initiating devices is not suitable as a means of Encrypted Line Security in UL Listed product.</i>			AES-128 <i>Note: AES-128 bit encryption for communication between control unit and initiating devices is not suitable as a means of Encrypted Line Security in UL Listed product.</i>		

* For UL Listed product, enable this frequency band.

A3. Electrical

	WP8010	WP8030																															
External AC/AC adaptor	Europe: 230VAC 50Hz input, 9VAC 700mA output. USA: 120VAC 60Hz input, 9VAC 1000mA output.	NA																															
External AC/DC adaptor	NA	External (wall-mounted) switching power supply 100VAC to 240VAC, 50/60 Hz, 0.5A / 12.5 VDC, 1.2A																															
Internal AC/DC	Internal switching power supply: Input: 100-240VAC, 0.12 A Max. Output: 7.5VDC, 1.2A Max.	Internal switching power supply: Input: 100-240VAC, 0.75A Output: 12.5 VDC, 1.6A.																															
Current Drain	Approx. 240 mA standby at the beginning (power ON) and then goes down to 90 mA standby, 1200 mA peak at full load. The Plink module draws 200mA in quiescent condition and 350mA during communication. The cellular modem draws 25mA in quiescent condition and 300mA during communication. <i>Note: When there is an AC fail the Plink module is disconnected.</i>	Approx. 260 mA standby, at the beginning (power ON) and then goes down to 60 mA, 1400 mA max. current drain during alarm.																															
Low Battery Threshold	4.8 V	7.2 V (6-cell battery pack) 9.6 V (8-cell battery pack)																															
Backup Battery Pack	4.8V 1300 mAh, rechargeable NiMH battery pack, p/n GP130AAM4YMX, manufactured by GP or p/n LTT-1300AA4Y, manufactured by LTT. 4.8V 1800 mAh, rechargeable NiMH battery pack, p/n GP180AAH4YMX, manufactured by GP or p/n LTT-1800AA4Y, manufactured by LTT. 4.8V 2200 mAh, rechargeable NiMH battery pack, p/n GP220AAH4YMX, manufactured by GP or p/n LTT-2300AA4Y, manufactured by LTT. For UL Listed product, use these batteries only.	Backup Battery Options: <table border="1" style="margin-left: 20px;"> <thead> <tr> <th rowspan="2">Backup period</th> <th colspan="3">Maximum external devices current (1)</th> </tr> <tr> <th>1300 mAh 6 Battery Pack (2)</th> <th>1800 mAh 8-Battery Pack (3)</th> <th>2200 mAh 8-Battery Pack (4)</th> </tr> </thead> <tbody> <tr> <td>4h</td> <td>180 mA</td> <td>300mA</td> <td>380mA</td> </tr> <tr> <td>8h</td> <td>70 mA</td> <td>125 mA</td> <td>160 mA</td> </tr> <tr> <td>12h</td> <td>35 mA</td> <td>70 mA</td> <td>95 mA</td> </tr> <tr> <td>24h</td> <td>max backup w/o load 22 hours</td> <td>12 mA</td> <td>25 mA</td> </tr> <tr> <td>32h</td> <td>no backup</td> <td>0mA</td> <td>10 mA</td> </tr> <tr> <td>39h</td> <td>no backup</td> <td>no backup</td> <td>0 mA</td> </tr> </tbody> </table>	Backup period	Maximum external devices current (1)			1300 mAh 6 Battery Pack (2)	1800 mAh 8-Battery Pack (3)	2200 mAh 8-Battery Pack (4)	4h	180 mA	300mA	380mA	8h	70 mA	125 mA	160 mA	12h	35 mA	70 mA	95 mA	24h	max backup w/o load 22 hours	12 mA	25 mA	32h	no backup	0mA	10 mA	39h	no backup	no backup	0 mA
Backup period	Maximum external devices current (1)																																
	1300 mAh 6 Battery Pack (2)	1800 mAh 8-Battery Pack (3)	2200 mAh 8-Battery Pack (4)																														
4h	180 mA	300mA	380mA																														
8h	70 mA	125 mA	160 mA																														
12h	35 mA	70 mA	95 mA																														
24h	max backup w/o load 22 hours	12 mA	25 mA																														
32h	no backup	0mA	10 mA																														
39h	no backup	no backup	0 mA																														

3. WP8010 INSTALLATION

	WP8010	WP8030
	<p>Caution! Risk of explosion if battery is replaced by an incorrect type. Dispose of used batteries according to the manufacturer's instructions.</p> <p>Note: For compliance with CE standards the battery capacity must be at least 1300 mAh.</p>	<p>(1) The external devices must be connected between 12V and ground. The current for each specified backup period can be drawn from the batteries with the internal GSM and the proximity reader connected to the WP8030.</p> <p>(2) 7.2V 1300 mAh, rechargeable NiMH battery pack, p/n 130AAM6BMX, manufactured by GP or p/n LTT-AA1300LSDX6B, manufactured by LTT.</p> <p>(3) 9.6V 1800 mAh, rechargeable NiMH battery pack, p/n GP180AAH8BMX, manufactured by GP or p/n LTT-AA1800LSDX8B, manufactured by LTT.</p> <p>(4) 9.6V 2200 mAh, rechargeable NiMH battery pack p/n 220AAH8BMX, manufactured by GP or p/n LTT-AA2200LSDX8B, manufactured by LTT.</p> <p>Caution! Risk of explosion if battery is replaced by an incorrect type. Dispose of used batteries according to the manufacturer's instructions.</p> <p>Notes:</p> <p>1. For compliance with CE standards the battery backup period must be at least 12 hours.</p> <p>2. For compliance with UL standards the battery backup period must be at least 24 hours.</p> <p>Note: Only the LTT-AA2200LSDX8B battery pack is approved for use by UL.</p>
Time to Charge	80 % (~ 13 Hrs)	80 % (~ 30 Hrs) for all battery types
Optional Backup Battery Pack	See "Backup Battery Options" above	See "Backup Battery Options" table above
Time to Charge (optional backup battery pack)	80 % (~ 24 Hrs)	NA
Wired Detectors Total (Sum) Current	NA	36* mA max.
Site External Siren Current (EXT)	NA	450* mA max @ 12.5 VDC when powered by AC/DC (10.5 VDC when in standby mode)
Site Internal Siren Current (INT)	NA	450* mA max @ 12.5 VDC when powered by AC/DC (10.5 VDC when in standby mode)
		* Total WP8030 output current (of INT & EXT sirens, PGM output and detectors) cannot exceed 550 mA.
PGM	Current sink to control panel GND 100 mA max. Max. external DC voltage +30 VDC	Current sink to control panel GND 100 mA max. Max. external DC voltage +15 VDC
High Current / Short Circuit Protection	NA	All outputs are protected (automatic reset fuse)

3. WP8010 INSTALLATION

A4. Communication¹

	WP8010	WP8030
Communication	PSTN; GSM; GPRS; IP (for future use)	PSTN; GSM; GPRS; IP (for future use)
Built-in Modem	300 baud, Bell 103 protocol	300 baud, Bell 103 protocol
Data Transfer to Local Computer	Via RS232 serial port	Via RS232 serial port
Report Destinations	2 Monitoring Stations, 4 private telephones	2 Monitoring Stations, 4 private telephones
Reporting Format Options	SIA, Contact ID, Scancom, SIA IP, DSC PowerNet. Note: For UL Listed product, the communication formats used are SIA and Contact ID.	SIA, Contact ID, Scancom, SIA IP, DSC PowerNet. Note: For UL Listed product, the communication formats used are SIA and Contact ID.
Pulse Rate	10, 20, 33 and 40 pps - programmable	10, 20, 33 and 40 pps - programmable
Message to Private Phones	Tone	Tone or voice
Ring Detection	The unit does not support ring detection without DC voltage present on the telephone lines.	The unit does not support ring detection without DC voltage present on the telephone lines

A5. Physical Properties

	WP8010	WP8030
Operating Temp. Range	14°F to 120°F (-10°C to 49°C) Note: For UL Listed product, the ambient temperature is 32°F to 120°F (0°C to 49°C)	14°F to 120°F (-10°C to 49°C) Note: For UL Listed product, the ambient temperature is 32°F to 120°F (0°C to 49°C)
Storage Temp. Range	-4°F to 140°F (-20°C to 60°C)	-4°F to 140°F (-20°C to 60°C)
Humidity	93% relative humidity, @ 30°C (86°F)	93% relative humidity, @ 30°C (86°F)
Size	196 x 180 x 55 mm (7-5/8 x 7 x 2 in.)	266 x 201 x 63 mm (10-7/16 x 7-7/8 x 2-1/2 in.)
Weight	658g (23 Oz) (with battery)	1.44Kg (3.2 pounds) (with battery)
Color	White	White

A6. Peripherals and Accessory Devices

	WP8010	WP8030
Modules	GSM/GPRS, IP (future use)	GSM/GPRS, IP (future use)
Additional wireless devices	30 detectors, 8 keyfobs, 8 keypads, 4 sirens, 4 repeaters, 8 proximity tags	64 detectors, 32 keyfobs, 32 keypads, 8 sirens, 4 repeaters, 32 proximity tags
Wireless Devices and peripherals	Magnetic Contact: PGx945, PGx975 PIR Detectors : PGx904; PGx904P, PGx994, PGx984, PGx984P, PGx974, PGx974P, PGx924, PGx944 PIR Camera Detectors: PGx934; PGx934P Smoke Detector: PGx926/ PGx916 (optional) GSM Module: WPGSM Keyfob: PGx939, PGx929 Keypad: WP-LED (with tag), WP-Touch Indoor Siren: PGx901/PG9901 Outdoor Sirens: PGx911, PG9911 Repeater: PGx920 Gas: PGx913 (CO detector) Glass-break: PGx912 Temperature: PGx905 Shock: PGx935 Note: UL requires that when using remote smoke/CO detectors and repeaters, each detector must be within range (STRONG) of 2	Magnetic Contact: PGx945, PGx975 PIR Detectors : PGx904; PGx904P, PGx994, PGx984, PGx984P, PGx974, PGx974P, PGx924, PGx944 PIR Camera Detectors: PGx934; PGx934P Smoke Detector: PGx926/ PGx916 (optional) GSM Module: WPGSM Keyfob: PGx939, PGx929 Keypad: WP-LED (with tag), WP-Touch Indoor Siren: PGx901/PG9901 Outdoor Sirens: PGx911, PG9911 Repeater: PGx920 Gas: PGx913 (CO detector) Glass-break: PGx912 Temperature: PGx905 Shock: PGx935 Note: UL requires that when using remote smoke/CO detectors and repeaters, each detector must be within range (STRONG) of 2 repeaters at all times (for path redundancy –

¹ For EN/European compliance setting: Dual reporting PowerLink3 and PSTN (for both WP8010and WP8030) or PowerLink3 and GSM only for WP8030.

3. WP8010 INSTALLATION

	WP8010	WP8030
	<i>repeaters at all times (for path redundancy – UL 985).</i>	<i>UL 985).</i>

APPENDIX B. Working with Partitions

Your alarm system is equipped with an integrated partitioning feature that can divide your alarm system into three distinct areas identified as Partition 1 through 3. A partition can be armed or disarmed regardless of the status of the other partitions within the system. Partitioning can be used in installations where shared security systems are more practical, such as a home office or warehouse building. When partitioned, each zone, each user code and many of your system's features can be assigned to Partition 1 to 3. Each user code is assigned with the list of partitions it is allowed to control in order to limit access of users to certain partitions.

When partitioning is enabled, menu displays are changed to incorporate the partition feature and also each device, user, and proximity tag has additional partitions menu, where it is assigned to certain partitions and excluded from others.

Note: When Partition Mode is disabled, all zones, user codes, and features of the control panel will operate as in a regular unit. When partition mode is enabled, all zones, user codes, and features of the control panel are automatically assigned to Partition 1.

B1. User Interface and Operation

Refer to the control panel User's Guide APPENDIX B. PARTITIONING for a detailed description of the user interface (Arming/Disarming, siren behavior, show function, etc.), and APPENDIX A for keyfobs and keypads operation in Partition Mode.

B2. Common Areas

Common areas are areas used as walkthrough zones to areas of 2 or more partitions. There may be more than one common area in an installation depending on the layout of the property. A common area is not the same as a partition; it cannot be armed / disarmed directly. Common areas are created when you assign a zone or zones to 2 or 3 partitions. Table A1 summarizes the behavior of the different zone types in a common area.

Table A1 – Common Area Definitions

Common area zone types	Definition
Perimeter	<ul style="list-style-type: none"> Acts as defined only after the last assigned partition is armed AWAY or HOME. In case that one of the partitions is disarmed, an alarm initiated from this zone is ignored for all assigned partitions.
Delay zones	<ul style="list-style-type: none"> Delay zones will not trigger an entry delay unless all assigned partitions are armed. It is, therefore, not recommended to define delay zones as common areas.
Perimeter follower	<ul style="list-style-type: none"> Act as defined only after the last assigned partition is armed AWAY or HOME. In case that one of the partitions is disarmed, an alarm initiated from this zone is ignored for all assigned partitions. In case that one of the common area assigned partitions is in a delay state (and the other partitions are armed), the alarm will behave as a perimeter follower for this partition only. The event will be ignored for other assigned armed partitions.
Interior	<ul style="list-style-type: none"> Acts as defined only after the last assigned partition is armed AWAY. In case that one of the partitions is disarmed or armed HOME, an alarm initiated from this zone is ignored for all assigned partitions.
Interior follower	<ul style="list-style-type: none"> Acts as defined only after the last assigned partition is armed AWAY. In case that one of the partitions is disarmed or armed HOME, an alarm initiated from this zone is ignored for all assigned partitions. In case that one of the common area assigned partitions is in a delay state (and the other partitions are armed), the alarm will behave as an interior follower for this partition only. The event will be ignored for other assigned armed partitions.
Home / Delay	<ul style="list-style-type: none"> Acts as a Perimeter-Follower type when all assigned partitions are armed AWAY. Acts as a Delay type when at least one of the assigned partitions is armed HOME. Will be ignored when at least one of the assigned partitions is disarmed.
Emergency; Fire; Flood; Gas; Temperature; 24-hour silent; 24-hour audible; Non-alarm	<ul style="list-style-type: none"> Always armed.

Note: A Soak Test of Common areas cannot be initiated when one of its partitions is armed. When Soak Test of a Common area is active, an alarm event is ignored unless all the partitions that are assigned to the zone are armed.

APPENDIX C. Detector Deployment & Transmitter Assignments

C1. Detector Deployment Plan

Zone No.	Zone Type		Location		Chime (melody Location) or Off (*)	Sensor Type	Holder
	Default	Programmed	Default	Programmed			
1	Delay 1		Front Door				
2	Delay 1		Garage				
3	Delay 2		Garage Door				
4	Perimeter		Back Door				
5	Perimeter		Child Room				
6	Interior		Office				
7	Interior		Dining Room				
8	Perimeter		Dining Room				
9	Perimeter		Kitchen				
10	Perimeter		Living Room				
11	Interior		Living Room				
12	Interior		Bedroom				
13	Perimeter		Bedroom				
14	Perimeter		Guest Room				
15	Interior		Master Bedroom				
16	Perimeter		Master Bedroom				
17	Perimeter		Laundry Room				
18	Perimeter		Master Bathroom				
19	Perimeter		Basement				
20	24 h / audible		Fire				
21	24 h / audible		Fire				
22	Emergency		Emergency				
23	Emergency		Emergency				
24	24 h / silent		Basement				
25	24 h / silent		Office				
26	24 h / audible		Attic				
27	24 h / audible		Den				
28	non-alarm		Yard				
29	non-alarm		Hall				
30	non-alarm		Utility room				
31	Perimeter		Office				
32	Perimeter		Office				
33	Perimeter		Attic				
34	Perimeter		Attic				
35	Perimeter		Attic				
36	Perimeter		Attic				
37	Perimeter		Attic				
38	Perimeter		Attic				
39	Perimeter		Attic				
40	Perimeter		Attic				
41	Perimeter		Attic				
42	Perimeter		Attic				
43	Perimeter		Attic				
44	Perimeter		Attic				
45	Perimeter		Attic				
46	Perimeter		Attic				
47	Perimeter		Attic				
48	Perimeter		Attic				
49	Perimeter		Attic				
50	Perimeter		Attic				
51	Perimeter		Attic				
52	Perimeter		Attic				
53	Perimeter		Attic				
54	Perimeter		Attic				

3. WP8010 INSTALLATION

Zone No.	Zone Type		Location		Chime (melody Location) or Off (*)	Sensor Type	Holder
	Default	Programmed	Default	Programmed			
55	Perimeter		Attic				
56	Perimeter		Attic				
57	Perimeter		Attic				
58	Perimeter		Attic				
59	Perimeter		Attic				
60	Perimeter		Attic				
61	Perimeter		Attic				
62	Perimeter		Attic				
63	Perimeter		Attic				
64	Perimeter		Attic				

Zone Types: 1 = Exit / Entry 1 * 2 = Exit / Entry 2 * 3 = Home Delay * 4 = Interior Follower * 5 = Interior * 6 = Perimeter * 7 = Perimeter Follower * 8 = 24hr Silent * 9 = 24hr Audible * 10 = Emergency * 11 = Arming Key * 12 = Non-Alarm * 17 = Guard * 18 = Outdoor.

Zone Locations: Note down the intended location for each detector. When programming, you may select one of 13 custom locations – see "02:ZONES/DEVICES" menu).

Notes:

All zones are chime off by default. Enter your own choice in the last column and program accordingly.

There is only 1 hard-wired zone in WP8010 and 2 hard-wired zones in WP8030.

C2. Keyfob Transmitter List

Transmitter Data						AUX button Assignments	
No.	Type	Holder	No.	Type	Holder	Skip exit delay or Arming "instant"	
1			17			Indicate the desired function (if any)	
2			18				
3			19				
4			20				
5			21				
6			22				
7			23				
8			24				
9			25				
10			26				
11			27				
12			28				
13			29				
14			30				
15			31				
16			32				

Skip exit delay

Arming "instant"

C3. Emergency Transmitter List

Tx #	Transmitter Type	Enrolled to Zone	Name of holder
1			
2			
3			
4			
5			
6			
7			
8			
9			
10			

C4. Non-Alarm Transmitter List

Tx #	Transmitter Type	Enrolled to Zone	Name of holder	Assignment
1				
2				
3				
4				
5				
6				
7				
8				
9				
10				

APPENDIX D. Event Codes

D1. Contact ID Event Codes

Code	Definition
101	Emergency
110	Fire
114	Heat
120	Panic
121	Duress
122	Silent
123	Audible
129	Confirm panic
131	Perimeter
132	Interior
133	24 Hour (Safe)
134	Entry/Exit
137	Tamper/CP
139	Burglary verified
140	General alarm
151	Gas alarm
152	Freezer alert
153	Freeze alert
154	Flood alarm
158	High temperature
159	Low temperature
180	Gas trouble
220	Guard sensor alarmed
301	AC loss
302	Low system battery
311	Battery disconnect
313	Engineer reset
321	Bell
333	Expansion modem failure
344	RF receiver jam detect

Code	Definition
351	Telco fault
373	Fire detector trouble
374	Exit error alarm (zone)
350	Communication trouble
380	Sensor trouble
381	Inactive event
383	Sensor tamper
384	RF low battery
389	Sensor self-test failure
391	Sensor Watch trouble
393	Fire detector clean me
401	O/C by user
403	Auto arm
406	Cancel
408	Quick arm
412	Successful download/access
426	Door open event
441	Armed home
454	Fail to arm
455	Autoarm failed
456	Partial arm
459	Recent close event
570	Bypass
602	Periodic test report
607	Walk test mode
625	Time/Date change
627	Program mode entry
628	Program mode exit
641	Senior watch trouble

D2. SIA Event Codes

Code	Definition
AR	AC Restore
AT	AC Trouble
BA	Burglary Alarm
BB	Burglary Bypass
BC	Burglary Cancel
BJ	Burglary Trouble Restore
BR	Burglary Restore
BT	Burglary Trouble / Jamming
BV	Burglary Verified
BX	Burglary test
BZ	Inactive event
CF	Forced Closing
CG	Armed home
CI	Fail to Close
CL	Armed Away
CP	Auto Arm
CR	Recent Close
EA	Door Open
FA	Fire Alarm
FJ	Fire detector trouble
FR	Fire Restore

Code	Definition
LT	Phone Line Trouble
LX	Local Programming Ended
OP	Opening Report
OT	Fail to Arm
PA	Panic Alarm
PR	Panic Restore
QA	Emergency Alarm
RN	Engineer Reset
RP	Automatic Test
RS	Remote Program Success
RX	Manual Test
RY	Exit from Manual Test
TA	Tamper Alarm
TE	Communicator restored to operation
TR	Tamper Restore
TS	Communicator taken out of operation
UJ	Detector mask restore
UT	Detector mask
WA	Flood alarm
WR	Flood alarm restore
XR	Sensor Battery Restore

Code	Definition
FT	Fire Detector Clean
FX	Fire test
GA	Gas alarm
GJ	Gas trouble restore
GR	Gas alarm restore
GT	Gas trouble
GX	Gas test
HA	Holdup Alarm (duress)
JT	Time Changed
KA	Heat alarm
KH	Heat alarm restore
KJ	Heat trouble restore
KT	Heat trouble
LB	Local Program
LR	Phone Line Restore

Code	Definition
XT	Sensor Battery Trouble
YA	Fuse Fault
YH	Bell Restored
YI	Overcurrent Trouble
YM	System battery disconnect
YR	System Battery Restore
YT	System Battery Trouble / Disconnection
YX	Service Required
YZ	Service Completed
ZA	Freeze alert
ZH	Freeze alert restore
ZJ	Freezer alert restore
ZT	Freezer alert

D3. Understanding the Scancom Reporting Protocol Data Format

The SCANCOM data format consists of 13 decimal digits divided into 4 groups, from left to right, as shown on the right. Each channel is associated with a specific event as follows:

- 1st "C": Fire
- 2nd "C": Personal attack
- 3rd "C": Intruder
- 4th "C": Open/close
- 5th "C": Alarm cancel
- 6th "C": Emergency
- 7th "C": Second alarm
- 8th "C": Trouble messages

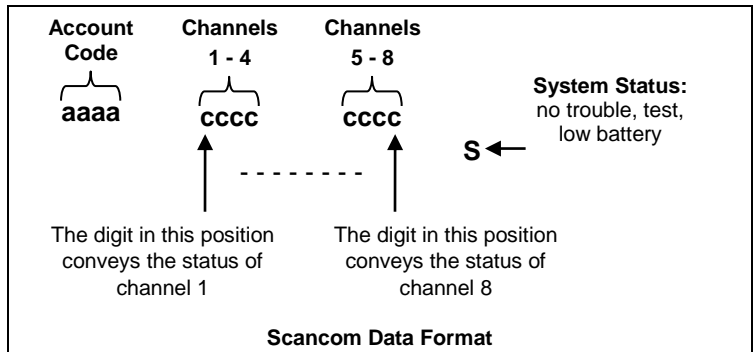

D4. SIA over IP - Offset for Device User

Type	Number Range In decimal	Example	Remarks
System reports	00	System tamper would report as 000	
Normal Zones/Detectors	1-499	Zone 5 would report as 005	
Keyfobs / Users /Tags	501-649	Keyfob/User number 101 would report 601	
Pendants	651-699	Pendant number 1 would report 651	
Keypads/ASU	701-799	Keypad number 8 would report 708	
Sirens	801-825	Siren number 9 would report 809	
Repeaters	831-850	Repeater number 4 would report 834	
Expanders/Bus devices/PGM	851-875	Device number 2 would report 852	
Troubles for:			
GSM	876	GSM module network fail 876	
BBA	877	BBA bus trouble 877	
Plink	878		
Guard	879		
	901- 999		For future use

3. WP8010 INSTALLATION

APPENDIX E. Sabbath Mode

E1. General Guidance

The Sabbath Mode allows you to use the alarm system without violating the Sabbath. The basic feature of this alarm system is that the PIR sensors are not activated during Disarm mode.

The method of installation, as illustrated in the drawing below, is used in order to prevent transmission from the magnetic contact device. The PG9945 device is used only as a transmitting device to report the status of the door to the control panel. A wired magnetic contact is connected to the input of the PG9945 device and an open/close switch is connected in parallel to the PG9945 input.

Note: Before the Sabbath, closing the circuit neutralizes the detector's magnet. You can use the front door without violating the Sabbath. On the Sabbath day itself, you can open the switch to allow the door to be protected. This operation is permitted on the Sabbath and also when the control panel is armed.

E2. Connection

1. Enroll an PG9945 to the WP8010/WP8030 control panel (see section 5.4.2).
2. Configure the "Input #1" setting option of the PG9945 to "Normally Closed" (refer to the PG9945 Installation Instructions, section 2.3).
3. Connect to the PG9945 a wired magnetic contact to be installed on the door and that is operated by opening/closing the door (see drawing below).
4. An open/close switch must be connected in parallel to the input of the PG9945.

Wiring Setup

- A. PG9945 device
- B. Wired magnetic contact
- C. Fixed frame
- D. Moving part
- E. Open/close switch
 - E1. Closed
 - E2. Open

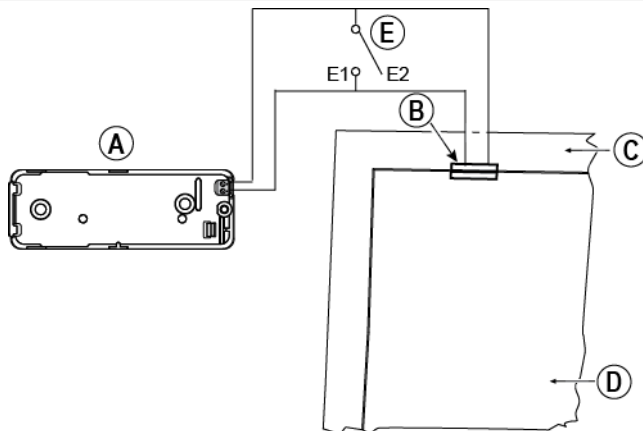

E3. Arming the System by Sabbath Clock

1. Enroll an PG9945 to the WP8010/WP8030 control panel (see section 5.4.2).
2. Configure the Zone Type to "11.Arming Key" (see section 5.4.2)
3. Configure the "Input #1" setting option of the PG9945 to "Normally Open" (refer to the PG9945 Installation Instructions, section 2.3).
4. From the "03:CONTROL PANEL" menu, configure the "09:ARMING KEY" setting option to "arm HOME" (see section 5.5.2).

Note: When the alarm system is armed at night by a Sabbath clock, the open / close switch must be opened when the door is closed.

APPENDIX F. PowerLink3 IP Communicator^{1, 2}

IMPORTANT NOTICE

DSC is a manufacturer and supplier of equipment. DSC DOES NOT provide PowerManage services including event notification or other forwarding services.

In order to benefit fully from the PowerLink3 IP Communicator, it must be connected to a central monitoring station or other service provider running DSC's PowerManage.

The PowerLink3 IP Communicator is compatible with the WP8010/WP8030 control panel version 17 and above.

F1. Getting Started

The DSC PowerLink3 IP Communicator provides a communication channel to the PowerManage server and enables you to send events, including alarm images of PIR cameras, and to manage panel configuration. (For detailed information, refer to the PowerManage User's Guide.)

Note: PowerLink3 IP Communicator does not include viewing by cameras or control of options via a web interface.

F2. Specifications

SOFTWARE	
Security System	<ul style="list-style-type: none"> • WP8010/WP8030r events reporting to PowerManage servers • Providing communication channel to PowerManage servers
Management	<ul style="list-style-type: none"> • IP Address: Auto configuration or Manual Configuration • Reset to Factory Defaults Option • Remote Firmware Upgrade
Data Security	<ul style="list-style-type: none"> • AES 128 Bit encryption for SIA-IP WP8010/WP8030 events
HARDWARE	
WP8010/WP8030 Connection	<ul style="list-style-type: none"> • RS-232
Size	<ul style="list-style-type: none"> • 73 x 61.5 x 16mm (2-7/8 x 2-7/16 x 5/8 in.)
Weight	<ul style="list-style-type: none"> • 50g (1.8 oz.)
Color	<ul style="list-style-type: none"> • Silver
Operating Temperature	<ul style="list-style-type: none"> • -10°C to 55°C (14°F to 131°F)
Storage Temperature	<ul style="list-style-type: none"> • -20°C to 60°C (-4°F to 140°F)



¹ PowerLink3 IP Communicator is not applicable for UL installations

² In the menus, PowerLink3 IP Communicator appears as "Broadband" or "Broadband Module".

3. WP8010 INSTALLATION

F3. Installation

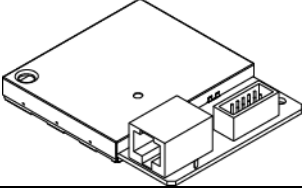
Package Contents

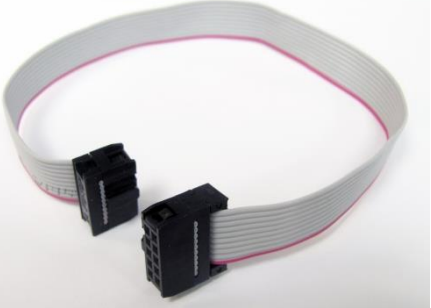
1 x DSC PowerLink3 IP Communicator	 A white, rectangular electronic device with a network port on the left and a multi-pin connector on the right.
1 x 2m (6.5 feet) Cat-5 Cable	 A coiled yellow Ethernet cable with RJ45 connectors on both ends.
1 x RS-232 Cable	 A white flat ribbon cable with two black RS-232 connectors.

System Requirements

- WP8010/WP8030 Security System.
- High-Speed Internet connection (Cable or DSL) enabled via a Home Router (Ethernet Based).
- One free Ethernet port on the home router for the PowerLink3 IP Communicator connection.

F4. Installing the DSC PowerLink3 IP Communicator

Perform the following instructions for the DSC PowerLink3 IP Communicator hardware installation:

Note PowerLink3 IP Communicator operation is not backed up by the control panel's battery and it is shut down during AC failure.

Hardware Installation

Note: The WP8010/WP8030 supports the use of the PowerLink IP communicator and GSM module.

Step 1.

Open the control panel:

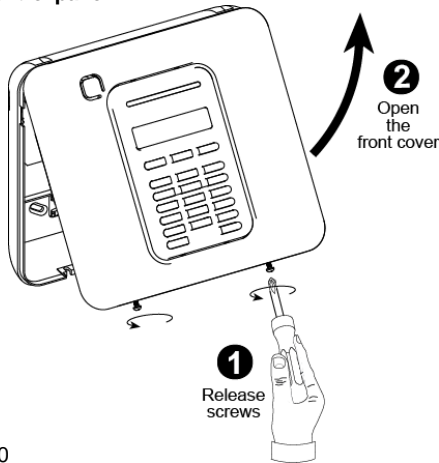

WP8010

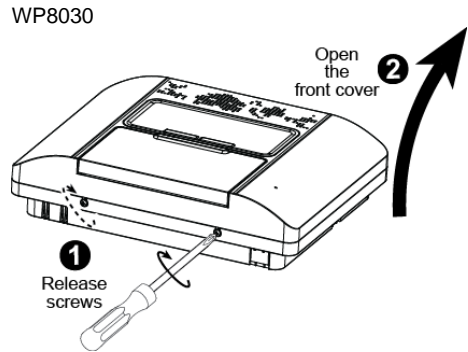

Step 2.

Mount the Internal PowerLink3 IP Communicator into the control panel and fasten it with 2 screws:

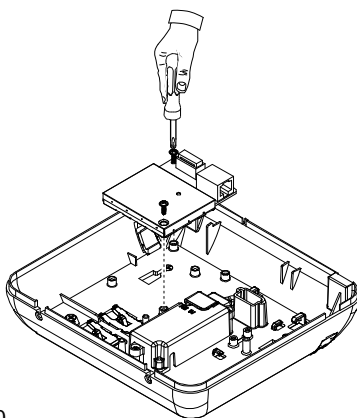

WP8010

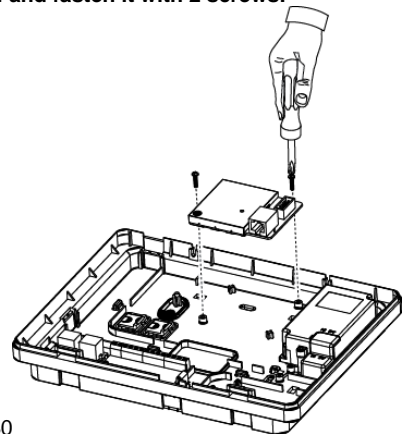

WP8030

3. WP8010 INSTALLATION

Step 3

WP8010:

1. Connect the flat cable from the front panel to the PowerLink3 IP Communicator.
2. Connect the Cat-5 cable from the PowerLink3 IP Communicator to the home router:

WP8030:

1. Connect the flat cable from the front panel to the PowerLink3 IP Communicator.
2. Connect the Cat-5 cable from the PowerLink3 IP Communicator to the home router:

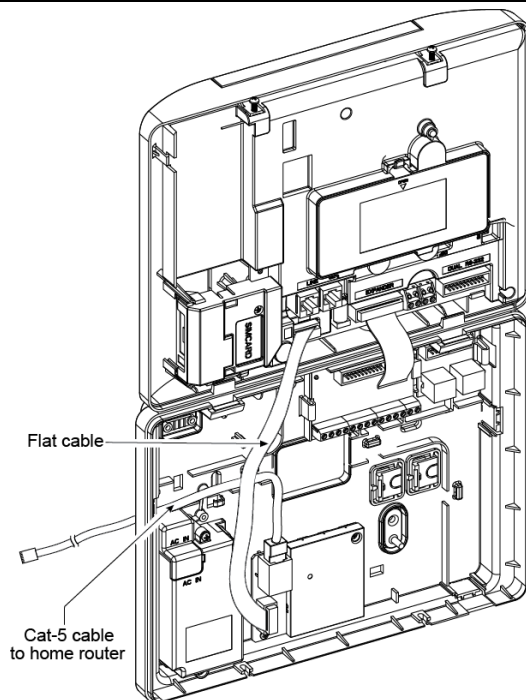
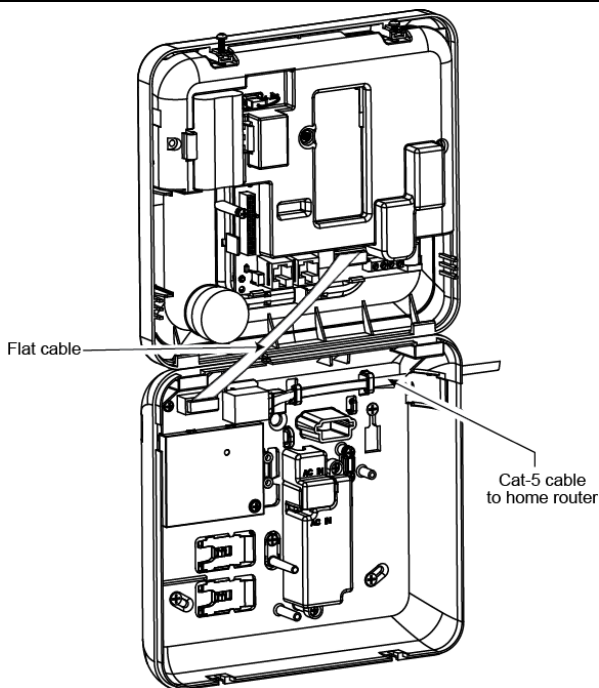

Note: To verify proper operation of the PowerLink3 IP Communicator, refer to the WP8010/WP8030 Installer's guide, section 5.9.5 "Testing the Broadband/PowerLink Module".

Notes:

1. To prevent interference to the antenna, do not route the Cat-5 cable through the cable entry knockout on the right side of the panel.
2. To verify proper operation of the PowerLink3 IP Communicator, refer to the WP8010/WP8030 Installer's guide, section 5.9.5 "Testing the Broadband/PowerLink Module".

Step 4.

Close the panel and secure with 2 screws:

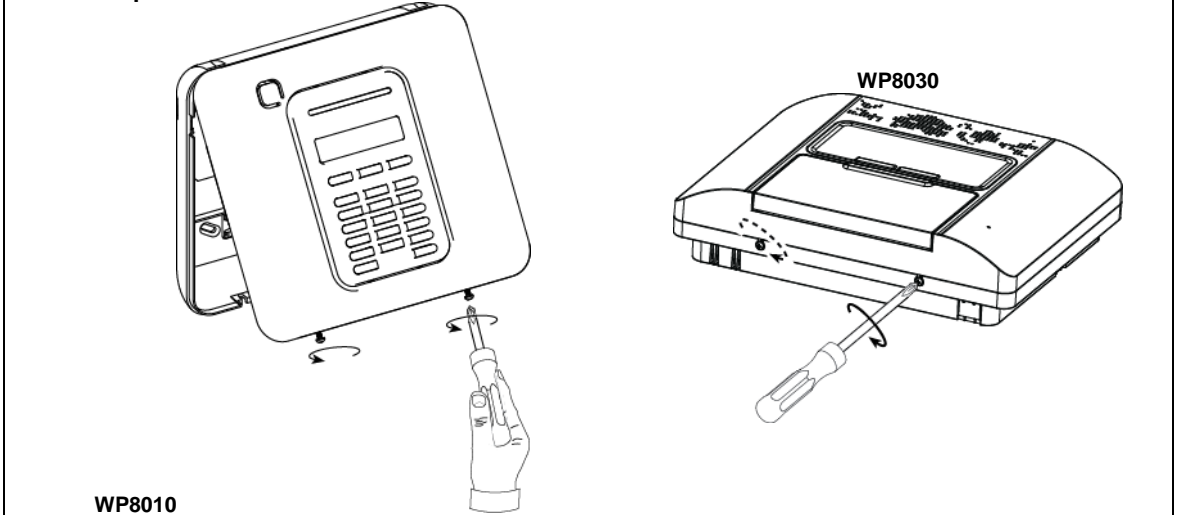

Control Panel Configuration

The PowerLink3 IP Communicator is integrated with the WP8010/WP8030 control panel. This facilitates in the setup of the required menus that are familiar to the installer.

For detailed programming instructions of the menus, the installer should refer to section 5.6 "Communication".

Setting the Communication Channel

Follow the instructions below to enable DHCP or to set the PowerLink3 IP Communicator IP address.

1. From the WP8010/WP8030 control panel, enter "INSTALLER MODE" menu using the Installer Code.
2. Enter the "04:COMMUNICATION" menu.
3. Enter the "7:BROADBAND" menu.
4. Select "Manual IP or "DHCP Client" and set either one.

Note If "7:BROADBAND" does not appear or if it is not possible to enter the menu, check to make sure that the PowerLink3 IP Communicator has been correctly installed.

Programming for Configuring Events Reporting to Central Stations

Follow the instructions below to select the type of events to be reported and to determine the method used for reporting events.

1. From the WP8010/WP8030 control panel, enter "INSTALLER MODE" menu using the Installer Code.
2. Enter the "04:COMMUNICATION" menu.
3. Enter the "3:C.S. REPORTING" sub-menu.
4. Program the following menus:
 - "01:REPORT EVENTS" – Select the type of events that the control panel will report to the Central Station.
 - "02:1st RPRT CHAN/03:2nd RPRT CHAN/04:3rd RPRT CHAN" – Define the 1st/2nd/3rd priority of method used to report events. Select the "broadband" option for PowerLink3 IP Communicator.
 - "21:IP RCVR 1/22:IP RCVR 2" – Enter the Central Station IP address the PowerLink3 IP Communicator will report to (not mandatory field).

3. WP8010 INSTALLATION

APPENDIX G. Glossary

Abort Period: When an alarm is initiated, the internal sounder is activated first for a limited period of time which is the abort period set by the installer. If you cause an alarm accidentally, you can disarm the system within the abort period before the real sirens start and before the alarm is reported to the *remote responders*.

Alarm: There are 2 kinds of alarms:

Loud alarm - both internal and external sirens blare out constantly and the control panel reports the event by telephone.
Silent alarm - the sirens remain silent, but the control panel reports the event by telephone.

A state of alarm is caused by:

- Motion detected by a *motion detector* (when the system is in the Armed state)
- Change of state detected by a *magnetic contact detector* - a closed window or door is opened
- Detection of smoke by a *smoke detector*, detection of gas by a *gas detector* and detection of water based fluids by a *flood detector* (when in any state)
- *Tampering* with any one of the detectors
- Pressing the two emergency buttons simultaneously (panic).

Arming: Arming the alarm system is an action that prepares it to sound an alarm if a zone is "violated" by motion or by opening a door or window, as the case may be. The control panel may be armed in various modes (see *AWAY*, *HOME*, *INSTANT* and *LATCHKEY*).

Assigned: Refers to zones.

Associated: Refers to devices.

AWAY: This type of arming is used when the protected site is vacated entirely. All zones, *interior* and *perimeter* alike, are protected.

Chime Zones: Allow you to keep track of activity in the protected area while the alarm system is in the disarmed state. Whenever a chime zone is "opened", the buzzer beeps twice. The buzzer does not beep, however, upon closing the zone (return to normal). Residences can use this feature to annunciate visitors or look after children. Businesses can use it to signal when customers enter the premises or when personnel enter restricted areas.

Note: *Your installer will never designate a 24-hour zone or a fire zone as a chime zone, because both zone types actuate an alarm if disturbed while the system is in the disarmed state.*

Although one zone or more are designated as chime zones, you can still enable or disable the chime function.

Communicators: Refers to communication channel, for example, GSM.

Control Panel: The control panel is a cabinet that incorporates the electronic circuitry and microprocessor that control the alarm system. It collects information from various sensors, processes it and responds in various ways. It also includes the user-interface - control keys, numerical keypad, display, sounder and loudspeaker.

Default Settings: Settings that are applicable to a specific device group.

Detector: The device (apparatus) that sends an alarm, that communicates with the control panel (for example, PG9904 is a motion detector; PG9926 is a smoke detector).

Disarming: The opposite of arming - an action that restores the control panel to the normal standby state. In this state, only *fire* and *24-hour zones* will sound an alarm if violated, but a "*panic alarm*" may also be initiated.

Disturbed Zone: A zone in a state of alarm (this may be caused by an open window or door or by motion in the field of view of a motion detector). A disturbed zone is considered "not secured".

Forced Arming: When any one of the system zones is *disturbed* (open), the alarm system cannot be armed. One way to solve this problem is to find and eliminate the cause for zone disturbance (closing doors and windows). Another way to deal with this is to impose **forced arming** - automatic de-activation of zones that are still *disturbed* upon termination of the exit delay. Bypassed zones will not be protected throughout the arming period. Even if restored to normal (closed), bypassed zones will remain unprotected until the system is disarmed.

Permission to "force arm" is given or denied by the installer while programming the system.

HOME: This type of arming is used when people are present within the protected site. A classic example is night-time at home, when the family is about to retire to bed. With HOME arming, perimeter zones are protected but interior zones are not. Consequently, motion within interior zones will be ignored by the control panel, but disturbance of a perimeter zone will cause an alarm.

Instant: You can arm the system AWAY-INSTANT or HOME-INSTANT, thereby canceling the entry delay for all delay zones for the duration of one arming period.

For example, you may arm the control panel in the HOME-INSTANT mode and remain within the protected area. Only perimeter protection is active, and if you do not expect somebody to drop in while the system is armed, alarm upon entry via the main door is an advantage.

To disarm the system without causing an alarm, use your control keypad (which is normally accessible without disturbing a perimeter zone) or use a keyfob transmitter.

Latchkey: The Latchkey mode is a special arming mode in which designated "latchkey users" will trigger a "latchkey message" to be sent to a telephone when they disarm the system.

For example, if a parent wants to be sure that their child has returned from school and disarmed the system. Latchkey arming is only possible when the system is armed in the AWAY mode.

Location: Assigning a named location to a device (for example, Garage, Front Door etc.)

Magnetic Contact Detector, Wireless: A Magnet- controlled switch and a wireless PowerG transmitter in a shared housing. The detector is mounted on doors and windows to detect changes in state (from closed to open and vice versa). Upon sensing that a door or window is open, the detector transmits its unique identification code accompanied by an “alarm” signal and various other status signals to the control panel. The control panel, if not armed at that time, will consider the alarm system as “not ready for arming” until it receives a “restored” signal from the same detector.

Motion Detector, Wireless: A passive Infrared motion sensor and a wireless PowerG transmitter in a shared housing. Upon sensing motion, the detector transmits its unique identification code, accompanied by an alarm signal and various other status signals to the control panel. After transmission, it stands by to sense further motion.

Non-Alarm Zone: Your installer can designate a zone for roles other than alarm. For instance, a motion detector installed in a dark stairway may be used to switch on lights automatically when someone crosses the dark area. Another example is a wireless transmitter linked to a zone that controls a gate opening mechanism.

Quick Arming: Arming without a user code. The control panel does not request your user code when you press one of the arming buttons. Permission to use this arming method is given or denied by the installer while programming the system.

Remote Responder: A responder can be either a professional service provider to which the home or business owner subscribes (a *Monitoring Station*) or a family relation/friend who agrees to look after the protected site during absence of its occupants. The *control panel* reports events by telephone to both kinds of responders.

Restore: When a detector reverts from the state of alarm to the normal standby state, it is said to have been “restored”. A *motion detector* restores automatically after detection of movement, and becomes ready to detect again. This kind of “restore” is not reported to the remote *responders*.

A *magnetic contact detector* restores only upon closure of the protected door or window. This kind of “restore” is reported to the remote *responders*.

Sensor: The sensing element: pyroelectric sensor, photo-diode, microphone, smoke optical sensor etc.

Signal Strength: The quality link communication between the system components and the control panel.

Smoke Detector, Wireless: A regular smoke detector and a wireless PowerG transmitter in a shared housing. Upon detection of smoke, the detector transmits its unique identification code accompanied by an alarm signal and various status signals to the *control panel*. Since the smoke detector is linked to a special *fire zone*, a fire alarm is initiated.

State: AWAY, HOME, AWAY-INSTANT, HOME-INSTANT, LATCHKEY, FORCED, BYPASS.

Status: AC fail, low battery, trouble, etc.

User Codes: The WP8010/WP8030 is designed to obey your commands, provided that they are preceded by a valid security access code.

Unauthorized people do not know this code, so any attempt on their part to *disarm* or defeat the system is bound to fail. Some operations, however, can be carried out without a user code as they do not degrade the security level of the alarm system.

Zone: A zone is an area within the protected site under supervision of a specific detector. During programming, the installer allows the *control panel* to learn the detector’s identity code and links it to the desired zone. Since the zone is distinguished by number and name, the control panel can report the zone status to the user and register in its memory all the events reported by the zone detector. Instant and delay zones are “on watch” only when the control panel is armed, and other (*24-hour*) *zones* are “on watch” regardless of whether the system is armed or not.

Zone Type: The zone type determines how the system handles alarms and other signals sent from the device.

APPENDIX H. Compliance with Standards

Compliance with Standards



Hereby, DSC declares that the PowerG series of central units and accessories are designed to comply with:

- **U.S. Standards:** (FCC) CFR 47 part 15 and part 68, UL 1023 and UL 985
- **Canada Standards:** RSS 210
- **European CE Standards**

The WP8010/WP8030 complies with the RTTE requirements - Directive 1999/5/EC of the European Parliament and of the Council of 9 March 1999.

According to the European standard EN50131-1, EN 50131-3 and EN 50131-4 Type Z, the WP8010/WP8030 security grading is 2 - "low to medium risk" and environmental classification is II – "indoor general" and the power supply type is A. EN 50131-6.

- **WP8010:** EN 50131-10, Type Z
- **GSM standards:**
- **Europe:** Complies with CE standards 3GPP TS 51.010-1, EN 301 511, EN301489-7
- **UK standards:**

This product is suitable for use in systems installed to conform to PD6662:2010 at Grade 2 and environmental class 2. DD243 and BS8243.

● **Applica T&C:**

WP8010 and WP8030 are certified by Norwegian accredited certification body Applica Test & Certification AS in accordance with: EN 50131-1, EN 50131-3, EN 50131-6, EN 50136-1 and EN 50136-2. Category DP4 (Dual path operation mode) only by PLINK3 (BBA) (primary) and GSM 350 (alternative). **WP8010:** EN 50131-10, Type Z

Applica T&C has certified only the 868 MHz variant of this product.

● **Security Grade:**

According to EN 50131-1:2006 and A1:2009, this equipment can be applied in installed systems up to and including Security Grade 2.

● **EN 50131-1 Environmental Class**

Class II

USA: CFR 47 Part 22 (GSM850) and Part 24 (GSM 1900).

● **SIA CP01 standards:**

For SIA CP01, a siren must be used in the system installation.

WARNING! Changes or modifications to this unit not expressly approved by the party responsible for compliance could void the user's authority to operate the equipment.

Canada: Le présent appareil est conforme aux CNR d'Industrie Canada applicables aux appareils radio exempts de licence. L'exploitation est autorisée aux deux conditions suivantes : (1) l'appareil ne doit pas produire de brouillage, et (2) l'utilisateur de l'appareil doit accepter tout brouillage radioélectrique subi, même si le brouillage est susceptible d'en compromettre le fonctionnement.

Industry Canada Declaration

This product meets the applicable Industry Canada technical specifications/Le présent matériel est conforme aux spécifications techniques applicables d'Industrie Canada.

The Ringer Equivalence Number is an indication of the maximum number of devices allowed to be connected to a telephone interface. The termination on an interface may consist of any combination of devices subject only to the requirement that the sum of the RENs of all the devices does not exceed five/L'indice d'équivalence de la sonnerie (IES) sert à indiquer le nombre maximal de terminaux qui peuvent être raccordés à une interface téléphonique. La terminaison d'une interface peut consister en une combinaison quelconque de dispositifs, à la seule condition que la somme d'indices d'équivalence de la sonnerie de tous les dispositifs n'excède pas 5.

The Ringer Equivalence Number (REN) for this terminal equipment is 0.3B.

This device complies with FCC Rules Part 15 and with Industry Canada licence-exempt RSS standard(s). Operation is subject to two conditions: (1) This device may not cause harmful interference, and (2) this device must accept any interference that may be received or that may cause undesired operation.

This device has been tested and found to comply with the limits for a Class B digital device, pursuant to Part 15 of the FCC Rules. These limits are designed to provide reasonable protection against harmful interference in residential installations. This equipment generates uses and can radiate radio frequency energy and, if not installed and used in accordance with the instructions, may cause harmful interference to radio and television reception.

However, there is no guarantee that interference will not occur in a particular installation. If this device does cause such interference, which can be verified by turning the device off and on, the user is encouraged to eliminate the interference by one or more of the following measures:

- Re-orient or re-locate the receiving antenna.
- Increase the distance between the device and the receiver.
- Connect the device to an outlet on a circuit different from the one that supplies power to the receiver.
- Consult the dealer or an experienced radio/TV technician.

WARRANTY

DSC products manufactured by Visonic (the "Manufacturer") warrants this product only (the "Product") to the original purchaser only (the "Purchaser") against defective workmanship and materials under normal use of the Product for a period of twelve (12) months from the date of shipment by the Manufacturer.

This Warranty is absolutely conditional upon the Product having been properly installed, maintained and operated under conditions of normal use in accordance with the Manufacturers recommended installation and operation instructions. Products which have become defective for any other reason, according to the Manufacturers discretion, such as improper installation, failure to follow recommended installation and operational instructions, neglect, willful damage, misuse or vandalism, accidental damage, alteration or tampering, or repair by anyone other than the manufacturer, are not covered by this Warranty.

The Manufacturer does not represent that this Product may not be compromised and/or circumvented or that the Product will prevent any death and/or personal injury and/or damage to property resulting from burglary, robbery, fire or otherwise, or that the Product will in all cases provide adequate warning or protection. The Product, properly installed and maintained, only reduces the risk of such events without warning and it is not a guarantee or insurance that such events will not occur.

THIS WARRANTY IS EXCLUSIVE AND EXPRESSLY IN LIEU OF ALL OTHER WARRANTIES, OBLIGATIONS OR LIABILITIES, WHETHER WRITTEN, ORAL, EXPRESS OR IMPLIED, INCLUDING ANY WARRANTY OF MERCHANTABILITY OR FITNESS FOR A PARTICULAR PURPOSE, OR OTHERWISE. IN NO CASE SHALL THE MANUFACTURER BE LIABLE TO ANYONE FOR ANY CONSEQUENTIAL OR INCIDENTAL DAMAGES FOR BREACH OF THIS WARRANTY OR ANY OTHER WARRANTIES WHATSOEVER, AS AFORESAID.

THE MANUFACTURER SHALL IN NO EVENT BE LIABLE FOR ANY SPECIAL, INDIRECT, INCIDENTAL, CONSEQUENTIAL OR PUNITIVE DAMAGES OR FOR LOSS, DAMAGE, OR EXPENSE, INCLUDING LOSS OF USE, PROFITS, REVENUE, OR GOODWILL, DIRECTLY OR INDIRECTLY ARISING FROM PURCHASER'S USE OR INABILITY TO USE THE PRODUCT, OR FOR LOSS OR DESTRUCTION OF OTHER PROPERTY OR FROM ANY OTHER CAUSE, EVEN IF MANUFACTURER HAS BEEN ADVISED OF THE POSSIBILITY OF SUCH DAMAGE.

THE MANUFACTURER SHALL HAVE NO LIABILITY FOR ANY DEATH, PERSONAL AND/OR BODILY INJURY AND/OR DAMAGE TO PROPERTY OR OTHER LOSS WHETHER DIRECT, INDIRECT, INCIDENTAL, CONSEQUENTIAL OR OTHERWISE, BASED ON A CLAIM THAT THE PRODUCT FAILED TO FUNCTION.

However, if the Manufacturer is held liable, whether directly or indirectly, for any loss or damage arising under this limited warranty, **THE MANUFACTURER'S MAXIMUM LIABILITY (IF ANY) SHALL NOT IN ANY CASE EXCEED THE PURCHASE PRICE OF THE PRODUCT**, which shall be fixed as liquidated damages and not as a penalty, and shall be the complete and exclusive remedy against the Manufacturer.

When accepting the delivery of the Product, the Purchaser agrees to the said conditions of sale and warranty and he recognizes having been informed of.

Some jurisdictions do not allow the exclusion or limitation of incidental or consequential damages, so these limitations may not apply under certain circumstances.

The Manufacturer shall be under no liability whatsoever arising out of the corruption and/or malfunctioning of any telecommunication or electronic equipment or any programs.

The Manufacturers obligations under this Warranty are limited solely to repair and/or replace at the Manufacturer's discretion any Product or part thereof that may prove defective. Any repair and/or replacement shall not extend the original Warranty period. The Manufacturer shall not be responsible for dismantling and/or reinstallation costs. To exercise this Warranty the Product must be returned to the Manufacturer freight pre-paid and insured. All freight and insurance costs are the responsibility of the Purchaser and are not included in this Warranty.

This warranty shall not be modified, varied or extended, and the Manufacturer does not authorize any person to act on its behalf in the modification, variation or extension of this warranty. This warranty shall apply to the Product only. All products, accessories or attachments of others used in conjunction with the Product, including batteries, shall be covered solely by their own warranty, if any. The Manufacturer shall not be liable for any damage or loss whatsoever, whether directly, indirectly, incidentally, consequentially or otherwise, caused by the malfunction of the Product due to products, accessories, or attachments of others, including batteries, used in conjunction with the Products. This Warranty is exclusive to the original Purchaser and is not assignable.

This Warranty is in addition to and does not affect your legal rights. Any provision in this warranty which is contrary to the Law in the state or country where the Product is supplied shall not apply.

Warning: The user must follow the Manufacturer's installation and operational instructions including testing the Product and its whole system at least once a week and to take all necessary precautions for his/her safety and the protection of his/her property.

1/08

DSC

A Tyco International Company

©2016 Tyco International Ltd. and its Respective Companies. All Rights Reserved.

Toronto, Canada www.dsc.com

Printed in Israel

D-306233 Rev 0 (02/16)



D-306233

WP8010/WP8030Quick User Guide

Arming and Disarming the System

Step	Operation	User Actions	Notes
Optional	1 Press the Partition Selection button and then select a PARTITION (if Partition is enabled) – used to divide the alarm system into three independently controllable areas	# followed by any combination of , , or	A “protest” beep will be heard when selecting a partition to which no sensors / peripherals were enrolled.
	2 Arm AWAY - used to arm the system when the protected site is vacated entirely. Arm HOME – used to arm the system when people are present within the protected site. Disarm (OFF) – used to restore the control panel to the normal standby state	+ or enter code + or enter code + or enter code	ARM indicator lights steadily during the armed state. ARM indicator extinguishes during the disarmed state.
Optional	Quick arm AWAY (If Quick Arm is enabled) – used to arm in the AWAY state without a user code		Disarming the system also stops the siren alarm, irrespective of whether the alarm was initiated during the armed or the disarmed state.
	Quick arm HOME (If Quick Arm is enabled) – used to arm in the HOME state without a user code		
	Forced arming AWAY (system not ready) – used to arm the alarm system in the AWAY state when any of the system zones is disturbed	+ or enter code to silence the “protest” buzzer	
	Forced arming HOME (system not ready) – used to arm the alarm system in the HOME state when any of the system zones is disturbed	+ or enter code to silence the “protest” buzzer	
Optional	3 INSTANT – used to arm in the Instant mode, without an entry delay. LATCHKEY – used for keyfob transmitters 5 through 8 (WP8010) / 23 through 32 (WP8030)	(After arming HOME/AWAY) 	

Note: The factory default master user code is 1111. The code is not required if quick arming has been permitted by the installer. Change the factory default code to a secret code without delay (see section Chapter 6, section B.4 of the WP8010/WP8030G2 User’s Guide).

Initiating Alarms

Alarms	Actions	Notes
Emergency alarm	(≈ 2 sec.)	To stop the alarm, press and then key in your valid user code.
Fire alarm	(≈ 2 sec.)	
Panic alarm	+ (≈ 2 sec.)	

Preparing to Arm

Before arming, make sure that READY is displayed.

This indicates that all zones are secured and you may arm the system as desired.

If at least one zone is open (disturbed) the display will read:

This indicates that the system is not ready for arming and in most cases that one or more zones are not secured. However, it can also mean that an unresolved condition exists such as certain trouble conditions, jamming etc., depending on system configuration.

To review the open zones click **OK**. The details and location of the first open zone detector (usually an open door or window sensor) will be displayed. To fix the open zone, locate the sensor and secure it (close the door or window) – see "device locator" below. Each click of **OK** will display another open zone or trouble indication. It is highly recommended to fix the open zone(s), thus restoring the system to the state of "ready to arm". If you do not know how to do this, consult your installer.

Note: To quit at any stage and to revert to the "READY" display, click **←**.

Device Locator: The WP8010/WP8030 system has a powerful device locator that helps you to identify open or troubled devices indicated on the LCD display. While the LCD displays an open or faulty device, the LED on the respective device flashes indicating "it's me". The "it's me" indication will appear on the device within max. 16 seconds and will last for as long as the LCD displays the device.

Zone Bypass Scheme

Bypassing permits arming only part of the system and at the same time allowing free movement of people within certain zones when the system is armed. It is also used to temporarily remove from service faulty zones that require repair work or to deactivate a sensor if, for example, you are decorating a room.

You can set the Zone Bypass Scheme i.e. to scroll through the list of registered (enrolled) sensors to your WP8010/WP8030 system and to Bypass (deactivate) faulty or disturbed sensors (either READY or NOT-READY) or to Clear (reactivate) BYPASSED zones (sensors).

Once you have set a Bypass Scheme you can use the following 3 options:

- To quickly clear a bypassed zone i.e. to reactivate the bypassed zone – refer to Chapter 6, section B.1 of the WP8010/WP8030 User's Guide.
- To quickly review the bypassed zones – refer to Chapter 6, section B.2 of the WP8010/WP8030G2 User's Guide.
- To repeat (recall) the last used zone bypassing scheme – refer to Chapter 6, section B.3 of the WP8010/WP8030 User's Guide.

Event Notification by Telephone

The WP8010/WP8030 can be programmed for selective notification of event messages to private telephone subscribers – refer to Chapter 6, section B.11 of the WP8010/WP8030G2 User's Guide.

WP8010 control panels

In case of alarm the following voice signal will be sent to private telephones upon event reporting:

- * **FIRE:** ON - ON - ON - pause.... (- - - - -
- ** **BURGLAR:** ON continuously (————— ...)
- *** **EMERGENCY:** 2-tone siren; like an ambulance.

To stop the alarm notification – press "2" on your telephone keyboard. The alarm sound will stop immediately.

WP8030 control panels

When the called party answers a call initiated by the WP8030, he will hear a verbal message composed of the "house identity" and the type of event that occurred.

The called party can acknowledge the message by pressing a key on the telephone keypad, as follows.

Command	Key
Acknowledge only: The WP8010/WP8030 disengages the line and considers the event duly reported.	2
Acknowledge and listen-in: The protected site is "bugged" for sound for 50 seconds. The called party may prolong the listening session by pressing [3] again before the WP8010/WP8030 disengages the line, or by pressing [1] to speak.	3
Acknowledge and speak out: The called party may speak for 50 seconds to whoever is in the protected site. The called party may prolong the "speak out" session by pressing [1] again before the WP8010/WP8030 disengages the line, or by pressing [3] to listen.	1
Acknowledge and 2-way conversation: You and the called party can speak and listen without any necessity to switch the system from "listen-in" to "speak-out" and vice versa for 50 sec. (extendable).	6
Acknowledge and request a status report: The WP8010/WP8030 will issue a verbal report of system status. For example: [Disarm - ready to arm] or [Disarm - back door open] or [Disarm - alarm in memory].	9